

PULSAFEEDER®

Pulsafeeder's Sample Cooler part number 12-066-00 is a safe method of withdrawing water from boilers, steam lines or tanks containing chemicals and for cooling the withdrawn liquid for subsequent chemical analysis.

This rugged counter flow heat exchanger is easy to install. The inner coil, of type 316 Stainless Steel, is one piece construction.

Operating Benefits

- Easy to install.
- Safe method to withdrawing water.



Features

- One Piece Construction
- 316 Stainless Steel Inner Coil

Aftermarket

- Metering Pumps
- Cooling Tower Controllers
- Boiler Controllers
- Pre-Engineered Systems



Sample Cooler

Sample Cooler Specifications

Engineering Data

Shell:	304 Stainless Steel
Mounting Brackets:	304 Stainless Steel with (4) 3/8" Holes
End Caps:	304 Stainless Steel
1/4" NPT Adapters:	316 Stainless Steel
Maximum Coil Pressure:	2500 PSI (172.4 BAR)
Maximum Shell Pressure:	250 PSI (17 BAR)
Cooling Water Fittings:	Inlet & Outlet 3/8" NPT 304 Stainless Steel (female)
Net Weight:	8 lbs. (3.63 kg)

Custom Engineered Designs – Pre-Engineered Systems



Pre-Engineered Systems

Pulsafeeder's Pre-Engineered Systems are designed to provide complete chemical feed solutions for all electronic metering applications. From stand alone simplex pH control applications to full-featured, redundant sodium hypochlorite disinfection metering, these rugged fabricated assemblies offer turn-key simplicity and industrial-grade durability. The UV-stabilized, high-grade HDPE frame offers maximum chemical compatibility and structural rigidity. Each system is factory assembled and hydrostatically tested prior to shipment.

Dimensions

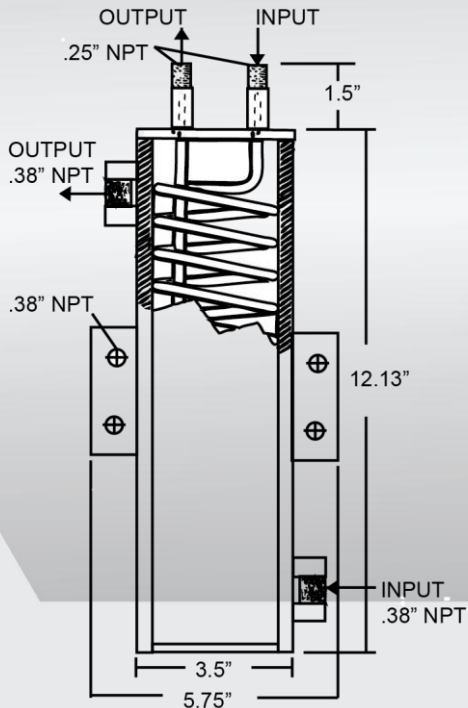

27101 Airport Road
Punta Gorda, FL 33982
Phone: ++1(941) 575-3800
Fax: ++1(941) 575-4085

www.pulsatron.com



An ISO 9001 Certified Company

SC001 J14

