

**MICROPROCESSOR-BASED
WATER TREATMENT
CONTROLLER**

**9200 SERIES
BOILER CONTROLLER**

**INSTALLATION
OPERATION
MAINTENANCE
INSTRUCTION**

FACTORY SERVICE POLICY

Your controller is a state of the art microprocessor based unit with on-board diagnostics. If you are experiencing a problem with your controller, first consult the troubleshooting guide in your operation and maintenance manual. If the problem is not covered or cannot be solved, please contact our Technical Services Department for further assistance.

Trained technicians are available to diagnose your problem and arrange a solution. Solutions may include purchase of replacement parts or returning unit to the factory for inspection and repair. All returns require a Return Authorization number to be issued by the manufacturer. Parts purchased to correct a warranty issue may be credited after an examination of original parts by the manufacturer. Warranty parts returned as defective which test good will be sent back freight collect. No credit will be issued on any replacement electronic parts.

Any modifications or out-of-warranty repairs will be subject to bench fees and costs associated with replacement parts.

WARRANTY

The manufacturer warrants control systems of its manufacture to be free of defects in material or workmanship. Liability under this policy extends for 24 months from date of shipment. The manufacturer's liability is limited to repair or replacement of any failed equipment or part which is proven defective in material or workmanship upon manufacturer's examination. This warranty does not include removal or installation costs and in no event shall the manufacturer's liability exceed the selling price of such equipment or part.

The manufacturer disclaims all liability for damage to its products through improper installation, maintenance, use, or attempts to operate such products beyond their functional capacity, intentionally or otherwise, or any unauthorized repair. The manufacturer is not responsible for consequential or other damages, injuries, or expense incurred through the use of its products.

The above warranty is in lieu of any other warranty, whether expressed or implied. The manufacturer makes no warranty of fitness or merchantability. No agent of ours is authorized to provide any warranty other than the above.

Note: Conductivity, pH and ORP probes are not covered under the controller warranty. These items carry their own manufacturer's warranty.

FCC WARNING

This equipment generates and uses radio frequency energy. If not installed and used properly, in strict accordance with the manufacturer's instructions, it may cause interference to radio communications. It has been type tested and found to comply with the limits for a class A computing device pursuant to subpart J of part 15 of FCC Rules, which are designed to provide reasonable protection against such interference when operated in a commercial or industrial environment. Operation of this equipment in a residential area is likely to cause interference in which case the user, at his own expense, will be required to take whatever measures necessary to correct the interference.

Microprocessor-Based Water Treatment Controller

9200 Series Boiler Controller

Contents

1. INTRODUCTION	4
Product description	4
2. INSTALLATION	5
Location	5
Installation Notes	6
Electrode Installation	6
Accessories	7
Electrical Wiring	7
3. START UP INSTRUCTIONS	9
Initialization	9
Front Panel	9
Menu Structure	10
Keypad Operation	10
Sample Programming	11
4. 9200 SERIES CONTROLLER SET-UP	13
General Information	13
System Configure	13
Contrast Adjustment	13
Day Week Date Time	13
Security Access Code	13
Hi Lo Alarm	14
Display Dampener	14
Scale/Range	14
Set Sample Mode	15
Selectable Inhibitor Timer	15
Totalizer	15
Analog Output Calibration and Settings	15
Alarm Relay Set	16
View Version Number	17
Set Points and Alarms	17
Rising or Falling Set Point	17
High or Low Alarm Settings	17
Set Point Differential	18
Timed Sample Settings	18
Selectable Inhibitor Feed Timer	19
5. SYSTEM CALIBRATION	20
Calibration Notes	20
Calibration Procedures	21
6. DIAGRAMS: INSTALLATION, COMPONENT, AND ELECTRICAL	22
(Note: Pages marked with tabs)	
7. SPECIFICATIONS	31
8. FACTORY DEFAULT VALUES	32
9. TROUBLESHOOTING	33
10. MAINTENANCE	35
11. GLOSSARY	36
12. 9200 BOILER SERIES PRODUCT LINE UP	38

1. INTRODUCTION

The MB9200 Series of microprocessor based controllers have been designed to control and monitor a wide range of parameters, both analog and digital.

This instruction manual covers the 9200 Series controllers. Refer to Table 1 for the specific standard features and options for the model number of your controller. All standard features are covered in this manual and most options have instructions where applicable.

IMPORTANT! While using this manual, if you see instructions for a feature that does not display on your controller, check the following:

- Consult Table 1 to see if that feature is available for your controller either as standard or option.
- Refer to the model number of your controller found on the enclosure of the unit. The letters after the model number are the options installed.
- After the above steps, if feature does not display, reinitialize the unit. If that fails, consult the factory.

For your convenience, there is an abbreviated instruction and software “MENU MAP” laminated card supplied with all manuals to be kept with the controller. This card is not a substitute for this instruction manual. It is supplied as a quick reference only and should be used in conjunction with the instruction manual.

DESCRIPTION

The 9200 Series of controllers is designed to monitor and control Total Dissolved Solids (TDS) in steam boiler systems in terms of electrical conductivity measured in microSiemens/cm ($\mu\text{S}/\text{cm}$). The controller allows the user to choose sample methods, either continuous sample or timed sample. A set point of the acceptable conductivity limit is entered into the controller through the front keypad. If the maximum limit is exceeded in the continuous sample mode, a blowdown valve is opened. The system water with higher levels of TDS is blown down while fresh make-up water is added. This results in reduced TDS levels in the boiler. In the timed sample mode, the controller opens the blowdown valve on a timed interval for a preset length of sample time. If TDS is below the set point, the valve will close until the next timed sample. If the TDS is above the maximum limit, the valve will remain open until the solids are reduced to below the set point.

The design also includes a high/low conductivity alarm indicator which is available with optional relay output and/or dry contacts. The alarms can be operated in one of two modes. In follow set point, an alarm off-set is entered and the alarms automatically adjust themselves around the set point. The other mode is independently set. This allows the user to independently set both the high and low alarms. The alarm conditions that will energize the output is programmable.

The design allows the 9200 Series to accept options such as selectable inhibitor feed timers, analog outputs, second boiler control and communications. A self charging capacitor is used to maintain time and history for up to two weeks. The EEPROM protects operating parameters during power outages. Hand/Off/Auto keys are provided on the keypad for immediate control of pumps, solenoid valves, etc., without scrolling through menus.

TABLE 1 The 9200 Series

STANDARD FEATURES	OPTIONS
9200	9200
Conductivity Control	Second Boiler Control (9220 only)
Selectable Sample Mode (Continuous or Timed)	Serial Line Communications with Software
Alarm Output Relay	Serial Line Communications with Software and Modem
Dry Alarm Contact	4-20 mA Isolated Programmable Proportional Output single or dual



**!!WARNING!!
CONTROLLER COULD
BE DAMAGED AND
VOID WARRANTY!**

Avoid locations where the controller would be subjected to extreme cold or heat [less than 0°F (-17.8°C) or greater than 122°F (50°C)], direct sunlight, vibration, vapors, liquid spills or EMI (electromagnetic interference; i.e., strong radio transmission and electric motors).

2. INSTALLATION

LOCATION

Select a mounting location convenient to grounded electrical and plumbing connections. Mount controller on a wall or other vertical surface. Position so operator has access to the unit and a clear view of front panel display. Avoid locations where the controller would be subjected to extreme cold or heat (See Warning at left!) Installation should comply with all national, state and local codes. For units without the panel mount option, an actual size mounting template is provided in the back of this manual for your convenience. Refer to Section 6, Diagram 1 and 1A, pgs. 22 and 23 for mounting details and dimensions of our standard enclosure and panel mount unit.

**FIGURE 1
Typical Installation**

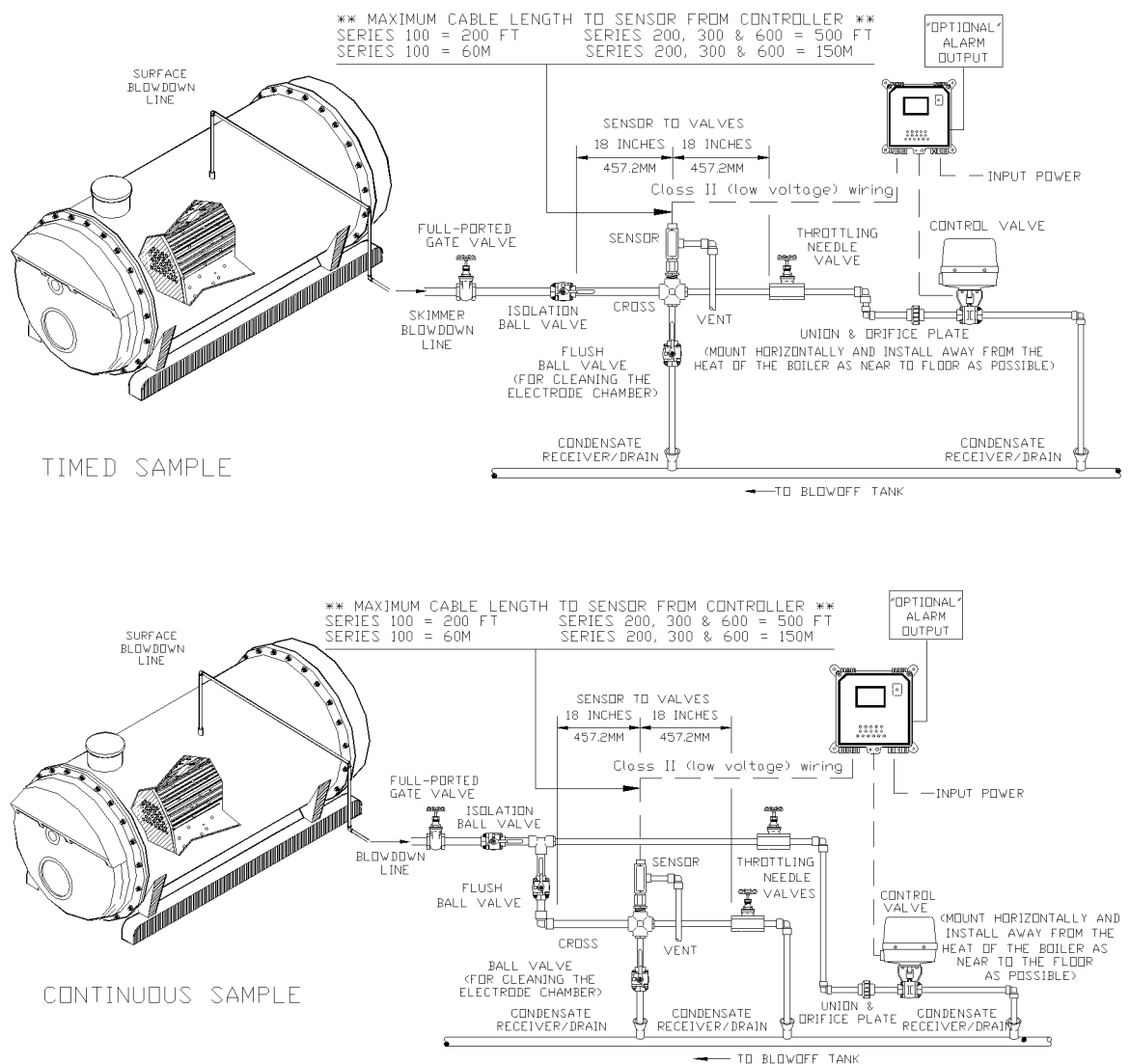

INSTALLATION NOTES

1. Assure skimmer line is 4 to 6 inches below the surface but not below the first row of tubes.
2. **DO NOT** use a column to automate blowdown.
3. **DO NOT** automate bottom blowdown.
4. Measuring surfaces of the electrodes must be continuously immersed in system water.
5. Valves installed between the electrode and the boiler must be full port.
6. A throttling device must be installed in the blowdown and sample line(s) on the system side of the blowdown valve and after the electrode. This will be used for throttling the blowdown.
7. Install water meters horizontally with meter face up and observe temperature and pressure ratings.
8. Electrode should be installed with a gate valve on the bottom of the cross for flushing and cleaning the electrode.
9. Blowdown valves should be mounted horizontally and installed away from heat of the boiler and near to the floor.
10. When installing sampling assembly and blowdown assembly, distances specified in Figure 1 should be adhered to as closely as possible.
11. Size of piping from boiler to sensor blowdown assembly should be maintained at the same diameter. Minimal use of 90° elbows should be used.
12. Electrode wiring is to be run in a dedicated conduit. Do **NOT** run in conduit with 120 VAC wiring. Connect conduit to top hole on access union - **NOT** side vent hole.
13. Flats on electrode should be perpendicular to the piping run. Refer to Section 6, Diagram 2, page 23.



!!WARNING!!

Always use extreme caution when installing or removing electrode. System water is HOT and under HIGH PRESSURE!

ELECTRODE INSTALLATION

Controller should be per installation diagram (see Figure 1). Make sure all fittings and connections are secure:

1. Remove power from the controller.
 2. Close isolation valve located before the electrode (Figure 1).
 3. Open the flush valve to drain water from electrode housing; to insure no water or pressure is present in this part of the assembly (Figure 1).
 4. Apply at least six wraps of teflon tape to threads of electrode. Install nipple and adapter if not already installed.
 5. Install electrode into cross housing. Make sure that the flats on the electrode are perpendicular to the piping run.
 6. Pass wires to the controller through threaded nipples, union and access tee. Leave vent open on access tee. Refer to Section 6, Diagram 2, page 23.
 7. Tighten all connections. Do not over tighten.
 8. Close flush valve. Open isolation valve up-line from electrode slowly to prevent water hammer. Carefully inspect for leaks.
 9. Make sure sample port on flow assembly is closed and apply pressure and flow by opening hand valves slowly to avoid water hammer.
- Refer to Section 6, Diagram 2, pg. 23, for information and specifications for the electrode supplied with your system.

ACCESSORIES

(Available through your distributor or manufacturer's sales representative, but not included as standard)

Boiler Conductivity Timed Sample

1. Blowdown valve, solenoid and motor operated ball valve.
2. Needle valve or orifice union and plates for throttling blowdown flow rate.
3. A full-port gate valve for isolation of blowdown assembly for cleaning and calibration.
4. A flush valve for sensor to empty sensor line for cleaning and calibration.
5. Chemical metering pumps as required.
6. Contact head water meter, if controller incorporates as pulse timer (optional).
7. External alarm, if controller incorporates alarm relay. Refer to Figure 1, Typical Installation, pg. 5.

Boiler Conductivity Continuous Sample

1. Blowdown valve, solenoid and motor operated ball valve.
2. Two needle valves or two orifice unions and plates for throttling blowdown.
3. A full-port gate valve for isolation of blowdown assembly.
4. A flush valve for sensor.
5. Chemical metering pumps as required.
6. Contact head water meter, if controller incorporates as pulse timer (optional).
7. External alarm, if controller incorporates alarm relay. Refer to Figure 1, Typical Installation.



!!WARNING!!

Line voltage is present on the power supply located behind the Safety/EMI cover behind the front panel. Line voltage is also present on the relay board located in the bottom of enclosure, even when power is off.

POWER MUST BE DISCONNECTED WHILE CONNECTIONS ARE BEING MADE!



!!NOTE!!

For proper rejection of AC line voltage spikes, sensor EMI noise rejection and personal safety, the case ground (SAFETY GROUND) must be properly installed. If there is ANY doubt, consult a qualified electrician.

ELECTRICAL WIRING

The 9200 electronic circuitry is protected with a 1 amp 250V fuse located on the power supply board.

Units are factory predrilled with easily accessible connectors for connection to the relay board. Units with the panel mount option have junction boxes which are factory prewired for ease of customer connection. Each connection is labeled in the junction box and wire nuts have been provided for connection. See Diagram 3, Relay Board, pg. 25, and Diagram 4, Electrical Output Connections, pg. 26, for input and output power connections.

The controller should be connected to its own 15 amp power branch (i.e., its own wiring, circuit breaker, etc.).

NOTE: Use only 16 or 18 AWG wire for conduit power and load connections. Never run power and signal wiring (Example: Sensor, proportional or recorder outputs) together in the same conduit.

NOTE: DIN connectors have been prewired to the side of the enclosure for standard and optional low voltage connections. Mating cables can be ordered to a customer specified length separately.

Power

The power connection is made on the relay board, J12. Terminal 1 = white return, 2 = ground and 3 = hot. For units with the panel mount option, power connection has been made to the relay board on J5 and run to a junction box for customer connection. Terminals: 1= black hot, 2 = white neutral, and 3 = green ground.

The controller should be connected to its own 15 amp power branch (i.e., its own wiring, circuit breaker, etc.). This connection supplies power to both the controller and relay con-

trolled devices. Use only 16 or 18 AWG wire.

Sensor Connections

Refer to Diagram 5, Daughter Board, pg. 26, for location of connections. For standard temperature compensated probe is used, five wire shielded cable, Consolidated 5731-CL or equivalent (shielded, five conductor 22AWT {0.76 mm²} stranded, with equivalent resistance and capacitance) should be used.

If non-temperature compensated probes, two-wire shielded cable should be used with shield being connected only at controller.

Water Meter/Pulse Timer

The available water meter connections have been prewired to a DIN connector on the side of the enclosure. This DIN is wired to the relay board at J11-9 & 10 (meter 1) and J11-13 & 14 (meter 2). If a Selectable Inhibitor Feed Mode is present and the Pulse Timer Mode is chosen, connect the water meter to the mating cable supplied with your unit. Each individual timer is supplied with its own water meter input connection. If more than one selectable timer is to be used as a pulse timer with only one water meter, short water meter 1 input connection (Pin 10) to any additional water meter connections (water meter 2 - Pin 14, water meter 3 - Pin 16).

These connections are provided on the Relay Board. This connection may or may not be made at the factory. If individual water meter inputs are required, make sure connections are individually made and not jumpered. Refer to Diagram 3, Relay Board, pg. 24.

The unit is supplied with 3 ft. mating water meter cable for customer connection. Longer cables are sold separately and may be ordered to customer specified lengths.

Alarm Dry Contact

Alarm dry contacts (Rated @ 500 mA) are wired to a DIN connector on the side of the enclosure. A mating cable, at a customer specified length, can be ordered separately. Refer to Diagram 3, Relay Board, pg. 24.

Use the Conduit Wiring Table (refer to Diagram 4, pg. 25) in conjunction with the Relay Board drawing (Diagram 3) for electrical output connections.

The unit is supplied with 3 ft. mating dry contact cable for customer connection. Longer cables are sold separately and may be ordered to customer specified lengths.

Relay

Relay connections are made through J3 through J9. Use only 16 or 18 AWG wire (refer to Diagram 3, pg. 24. for the location of connections). Refer to Diagram 4, Conduit Wiring Table, pg. 25, for relay assignments specific to your controller's model number. Each relay output is individually protected by a replaceable (Wickman 3721500041) plug-in 5 amp fuse located on the relay board.

There are 4 connections provided for each relay: 1=Normally Closed, 2=Normally Open, 3=Ground and 4=Return.

Typically an on/off device, like a pump, is wired in the normally open state (that is 1 and 3). When wired this way, the device is activated (i.e., turns on) when the relay activates. Some components, like motorized ball valves typically used for "blow-down", require power to be supplied in either state. In this situation, use all three contacts as illustrated in Diagram 3, pg. 24.



!!WARNING!!

When power is supplied to the unit, line voltage is present on the Relay Board located in the bottom of the enclosure even with the Logic Power switch off.



NOTE:

When Initializing or Re-Initializing your controller, all of the system settings will be overwritten by original factory default settings. The controller must be re-configured to your specifications.

3. Start Up Instructions

READ THE FOLLOWING BEFORE PROCEEDING ANY FURTHER!!

INITIALIZATION

This unit requires initialization upon start-up. Before applying power, insure that devices being controlled are not in a position to cause harm or damage if activated upon initial start-up. With the controller now installed in a convenient location, INITIALIZE the Controller. Supply power to the controller and turn the Logic Power switch on. The power LED indicator light will be illuminated. When controller is powered up, the **MAIN MENU-DISPLAY DATA** (shown right) will be displayed.:

1. Press **SCROLL DOWN** until **MAIN MENU-CONFIGURE** is displayed and press **ENTER**.
2. Press **SCROLL DOWN** until **CONFIGURE-FACTORY REINIT** is displayed and press **ENTER**.
3. Press **SCROLL DOWN** until **FACTORY REINIT-PRESS ENTER TO CONT.** is displayed. Press the **ENTER** key to execute Initialization. Press the **HOME** key repeatedly to return to the **MAIN MENU-DISPLAY DATA**.

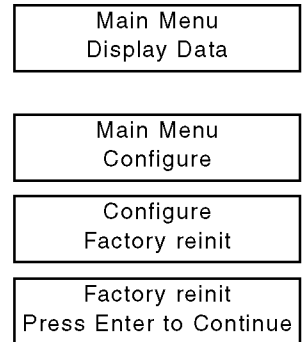
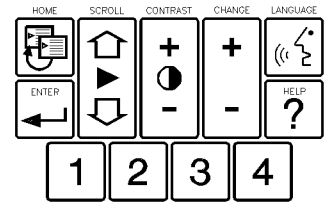

FRONT PANEL

Take a moment to review Figure 2, to become familiar with the 9200 Series front panel.

FIGURE 2
9200 Series
Front Panel

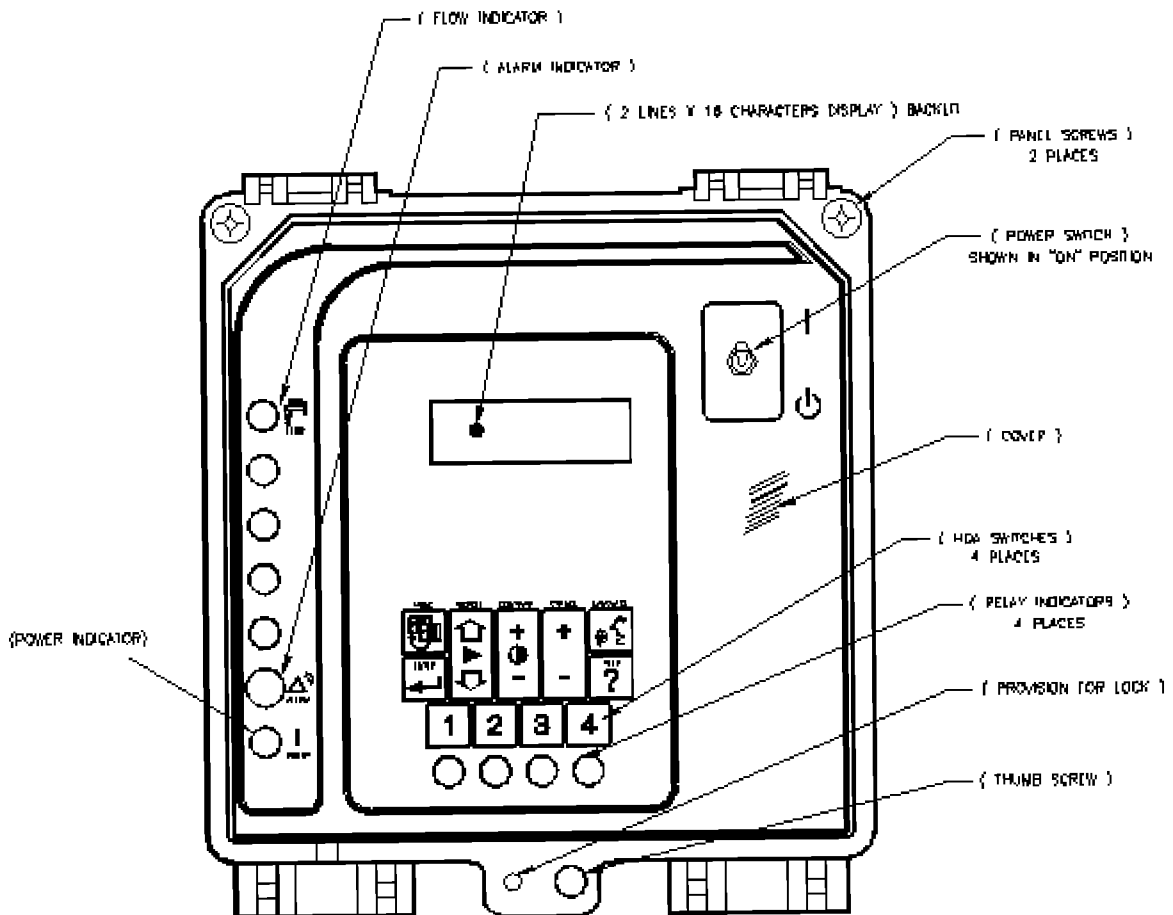



TIP:

For help with menu locations, please refer to the 'Menu Map' supplied with your controller.

MENU STRUCTURE

The menu structure as well as the hardware were designed with the user in mind. The menu structure diagram supplied with the controller was generated to reflect a 9200. The laminated "MENU MAP" supplied with your controller reflects your system with options ordered.

Display Data This menu displays system parameters only. No settings or adjustments are made through this menu. Present system Conductivity is displayed along with any active alarms.

Calibrate Sensor(s) This menu is for analog input sensor calibration, such as conductivity. In this menu, the user is prompted to choose either 2 or 3 point calibration. After a choice is made, the user is prompted to enter value of LO, MID (if 3 point is chosen) and HI calibration solution.

Set Points and Alarms In this menu, the user is prompted to enter settings pertaining to alarms and set points that control the system operation.

Inhibitor Feed Set In this menu, the user is prompted to enter settings pertaining to the inhibitor feed mode chosen in the System Configure menu.

System Configure This is generally the first selection made at start up. In this menu, the user is prompted to configure system functions and options to your specific application. System Configure can include such things as time of day, date, security code, track set point or independent set of high/low alarm, display dampener, rising or falling set points, alarm relay selections, operating scale, the selection of the inhibitor feed mode, water meter pulse totalizer, analog output selection, and sample mode type.

KEY PAD OPERATION

The Key Pad on the 9200 is easy to use and will guide you through all the sub menus and functions of the controller.

Feel free to try out these keys as you read about them. You will not hurt the controller and the values will need to be reprogrammed later anyway.

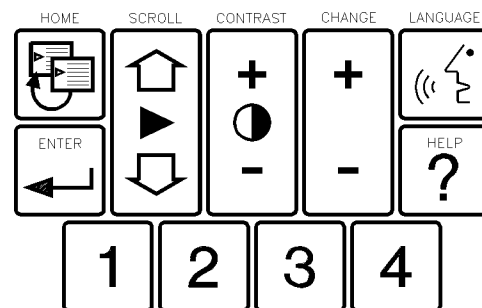

Home Press this key to return to previously displayed menu.

Scroll Up/Scroll Down Some menus contain more choices than can be displayed at once. Press

either scroll key to reveal other items on menu displayed. If no other choices are present, nothing will happen when pressing Scroll Keys. The Menu Map supplied with your controller will show you which menus need to be scrolled to show additional choices.

Contrast Up/Contrast Down Press these keys to control contrast of viewing screen.

Arrows The Arrow Keys are used to change the numerical values associated with the various settings you will be entering. Use "down" arrow to select lower numbers and the "up" arrow to select higher numbers.

Enter This key has two functions:

FIRST, in the main menus and in the sub menus, pressing the Enter Key will activate the selection.

SECOND, after selecting the value needed with the Arrow Keys, press the Enter Key to "lock-in" the value. The next value to be set (if one exists) in that particular sub-menu will be displayed.

Language This key is used for alternative foreign languages for our international customers. Spanish is installed as standard feature on the 9200 Series.



NOTE:

After five minutes of no keypad activity, the controller will display date, time, and system conductivity.



TIP:

When using the Arrow Keys, press once to change numbers by one unit. Continuously holding down either Arrow Key will change numbers more rapidly.

Help When pressed, this key will display simple instructions for the operation of the Enter, Home, Arrows, and Scroll keys.

Relays (1-4) These Hand/Off/Auto (HOA) keys allow immediate control of pumps, solenoid valves, etc. affected by the controller without scrolling through the menus. Press a Relay Key once to force relay on for 5 minutes (an amber light will appear below that key). Press Relay Key again to force relay off (a red light will appear below that key, relay will be forced off until key is pressed again). Press a Relay Key a third time to return relay to auto control (green light will indicate that relay is on, no light indicates that relay is not activated).



NOTE:

NEVER leave a screen with choices still 'flashing'!
Controller accuracy may be affected, and/or controller may not operate properly. If you forget, simply return to that menu and complete your programming.

SAMPLE PROGRAMMING

The following is a detailed example of how to program your controller. Once you have mastered this exercise, you will be ready to set up the controller to your specifications.

IMPORTANT! Please note that in all programming instructions, *keypad instructions* are presented as all capitals—"ENTER," items as they *appear in the display* are presented as all capitals and bold face—"DISPLAY DATA."

For this exercise, you will set "DAY, WEEK, DATE, and TIME."



1. If not already displayed, press HOME until **MAIN MENU DISPLAY DATA** is displayed.



2. Press SCROLL DOWN repeatedly until **MAIN MENU CONFIGURE** is displayed.
Press ENTER.



3. **CONFIGURE DATE/DAY/TIME** will be displayed.
Press ENTER.



4. The **DATE** menu will be displayed with "month" flashing. Use the ARROW keys to select the current month.
Press ENTER.



5. "Day" will begin flashing. Use the ARROW keys to select the current date.
Press ENTER.



6. "Year" will begin flashing. Use the ARROW keys to select the current year.
Press ENTER to complete **DATE** programming.

(Continued)



TIP:

Be sure to press keys firmly until you feel or hear a faint click, then pause before you try again. There is a very slight delay for the controller to react to your command. This is normal.



TIP:

If at any time, while programming your controller, you get lost or confused, press the HOME key repeatedly until you get back to the Main Menu and start again.



7. Press **SCROLL DOWN**. The **TIME** menu will display with “hours” flashing. Use the **ARROW** keys to select current hour (24 hour clock).

Press **ENTER**.



8. “Minutes” will begin flashing. Use the **ARROW** keys to select current minutes.

Press **ENTER**. Nothing should be flashing and that completes the Date, Day, and Time programming.

Congratulations, you’ve done it! All menu programming functions operate in this manner. Feel free to repeat this exercise as often as you like until you are comfortable with the programming procedure.

Now, press the **HOME** key repeatedly to return to **MAIN MENU, DISPLAY DATA**.



!!WARNING!!

When power is supplied to the unit, line voltage is present on the Relay Board located in the bottom of the enclosure even with the Logic Power switch off.



NOTE:

When Initializing or Re-Initializing your controller, all of the system settings will be overwritten by original factory default settings. The controller must be re-configured to your specifications.



TIP:

After pressing ENTER at the end of a setting procedure, if the next item to be set within a submenu does not display, press the HOME key to return to the submenu title then press SCROLL UP or SCROLL DOWN until you see the item to be set next.

4. 9200 CONTROLLER SET UP

GENERAL INFORMATION

Before applying power, insure that devices being controlled are not in a position to cause harm or damage if activated upon initial start-up. With the controller now installed in a convenient location, INITIALIZE Controller (see initialization procedure, pg. 9). Supply power to the controller and turn power switch on. The power LED indicator light will be illuminated. When controller is powered up, it will show **MAIN MENU-DISPLAY DATA** in the display.

The default values for all Control features have been factory set, but you will want to fine tune the controller to meet your specific application.

SYSTEM CONFIGURE

To configure the controller, press HOME key until **MAIN MENU DISPLAY DATA** appears in the display. SCROLL DOWN until **MAIN MENU-CONFIGURE** is displayed, then proceed with the following.

A) Set CONTRAST ADJUSTMENT:

1. If display contrast requires adjustment, use the CONTRAST UP or CONTRAST DOWN keys on the control panel key pad to adjust screen for best viewing.

B) Set DATE/DAY/TIME:

1. Please refer to Sample Programming (pg. 11).
2. When completed, press HOME key once to return to **MAIN-MENU CONFIGURE**.

C) Set SECURITY Access Code:

The Controller can be configured to have a Security Access Code. One must know this code to access the System Configure menu.

1. Press SCROLL DOWN to display **CONFIGURE-SECURITY** and press ENTER. **SECURITY CODE-DISABLED** will appear. (If a security code has been entered, enter security code using ARROW keys. Press ENTER, **CONFIGURE-DATE/DAY/TIME** will be displayed.)

To set a security code, press the UP ARROW key to program the desired code and press ENTER. Once a security code has been entered, the operator must know the code to access **MAIN MENU-CONFIGURE**.

2. To disable the code after it has been entered, you must first know the code. Enter the security code with the ARROW keys then, press SCROLL DOWN to display **CONFIGURE-SECURITY** and press ENTER.

3. Press and hold DOWN ARROW key until display shows **DISABLED** and press ENTER.

4. Press HOME once to return to **CONFIGURE-SECURITY** menu.

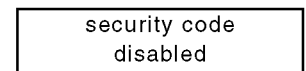
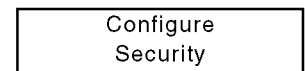
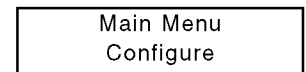
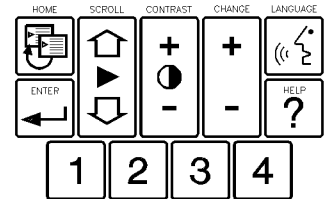
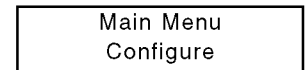
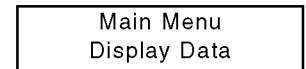
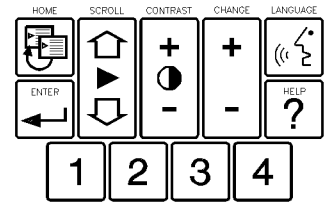



TIP:

After pressing ENTER at the end of a setting procedure, if the next item to be set within a submenu does not display, press the HOME key to return to the submenu title then press SCROLL UP or SCROLL DOWN until you see the item to be set next.



NOTE:

If the Scale-Range is changed (present scale will display in the 'Main Menu, Display Data' menu when you press the Home key), the keypad becomes inoperative for 15 seconds. A reminder will appear that a switch on the daughter board must be changed also! See table at right for proper switch configuration.



NOTE:

Recalibrate conductivity probe after changing scale.

D) Set HI/LO ALARM:

You have the choice to select “Track Set Point” or “Independent Set Point.” “Track Set Point” triggers Hi or Low alarm based on the same Alarm Offset range over or under the controller set point. “Independent Set Point” allows you to enter Hi and Low values of your choice over or under the controller set point.

1. SCROLL DOWN to **CONFIGURE-HI/LO ALARM**. Press ENTER and use the ARROW keys to choose the alarm configuration: **TRACKS SET PT** or **INDEPENDENT SET** of high and low alarms. Press ENTER when your choice is displayed. An asterisk (*) will appear next to your selection. Press HOME to return to **CONFIGURE-HI/LO ALARM**.

E) Set DISPLAY DAMPENER:

This setting determines the number of samples that are averaged together and the number of seconds before a new reading is displayed. This reduces the typical fluctuation of digital displays.

1. SCROLL DOWN to **CONFIGURE-DISPLAY DAMPENER**. Press ENTER, **DISPLAY DAMPENER-EVERY 1 SEC(S)** will display. Set sensitivity or display dampening with the ARROW keys, 1 being the most sensitive and 20 being the least. Press ENTER. Press HOME to return to **CONFIGURE-DISPLAY DAMPENER**.

Note: **DISPLAY DAMPENER** must be set at 1 for calibration.

F) Set INPUT SCALE/RANGE:

This selection lets you choose the conductivity range you wish your controller to monitor.

1. SCROLL DOWN to **CONFIGURE-INPUT SCALES**. Press ENTER. The display will show current scale selected with asterisk (*) next to it. Important: If the scale is changed, the keypad becomes inoperative for 15 seconds and **PLEASE CHANGE SWITCH ON CARD** will be displayed. This is a reminder that a switch on the daughter board must also be changed. Refer to the diagram on pg.--. After 15 seconds, the display will read the scale that was chosen (please change appropriate switch on conductivity daughter board). If your unit is equipped with a second boiler control, SCROLL DOWN for scale adjustment for second conductivity control. Press HOME to return to **CONFIGURE-INPUT SCALES**. Scale/Range Table (refer to Diagram 5, Conductivity Daughter Board, pg. 26)

Your 9200 comes from the factory pre-configured to monitor conductivity in the range of 0-5,000 µS/cm. The ranges listed in the Scale/Range Table can be selected by the setting of the five dip switches located just left of the sensor input on the conductivity daughter board. Refer to Diagram 5, pg. 26.

Note: Assure that only one switch is in the closed position. The corresponding range must also be selected from the keypad under **MAIN MENU-CONFIGURE** .

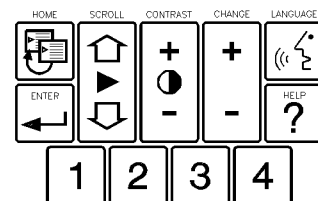

Configure Hi/Lo Alarm

hi/lo alarm *track set point

hi/lo alarm *independent set point

Configure Display Dampener

display dampener every 1 sec(s)

Configure Input Scales

sys cond us / cm *5000 switch 3

Please change switch on card

G) Set SAMPLE MODE

The Sample Mode determines whether your controller will monitor the boiler system water on a timed or continuous reading.

1. SCROLL DOWN to **CONFIGURE-SAMPLE MODE**. Press ENTER.
2. **SAMPLE MODE 1-CONSTANT SAMPLE** will be displayed. Use the ARROW keys to display either **CONSTANT SAMPLE** or **TIMED SAMPLE**. When your choice is shown, press ENTER and an asterisk (*) will confirm your selection. Press HOME key to return to Configure Menu.
3. If your controller is equipped with a second boiler control (Option E), press SCROLL DOWN for **SAMPLE MODE 2** and configure as described in step 2.

Configure
Sample Mode

sample mode 1
*constant sample

sample mode 1
timed sample

inh select
limit timer

H) Set SELECTABLE INHIBITOR TIMER

This selection lets you choose the method desired to control the operating duration of the inhibitor feed pump when activated by system blowdown.

1. SCROLL DOWN to **CONFIGURE-INH TIMER SELECT**. Press ENTER.
2. **INH SELECT - % POST BLEED, LIMIT TIMER, PULSE TIMER,** or **PERCENT TIMER** will display. An asterisk (*) will be next to the presently selected mode.
3. Press either ARROW key to display your choice.
4. Press ENTER, an asterisk (*), indicating present feed mode, will appear next to your selection.
5. Press HOME to return to **CONFIGURE-INH TIMER SELECT**.

Configure
Inh Timer Select

inh select
*% post bleed

inh select
limit timer

inh select
pulse timer

inh select
percent timer

I) Set TOTALIZER

The Totalizer displays the accumulated number of pulses received from a contact head equipped water meter. This selection lets you reset or enter a count value.

1. SCROLL DOWN to **CONFIGURE-RESET TOTALIZER**.
2. Press the ENTER key to display **COUNT TOTAL**. To **RESET TOTALIZER**, use the ARROW keys to set the reset to zero or the desired count and press ENTER.
3. Press HOME to return to **RESET TOTALIZER** menu.

Configure
Reset Totalizer

count total
0

J) Set ANALOG OUTPUT

The analog outputs designed for interfacing with recorders, pumps and computers.

The Proportional 4 to 20 mA output is designed to interface with an analog recorder, metering pump or computer. The output is 4 to 20 mA over a programmable range. For example, if the analog input was conductivity, the output could be programmed to be 4 mA at 6000 $\mu\text{S}/\text{cm}$, the "LO RANGE" set point, and 20 mA at 8000 $\mu\text{S}/\text{cm}$, the "HI RANGE" set point".

The analog outputs require calibration upon initial start up. Calibration is recommended after changing scales or after factory reinitialization. For accurate calibration of the analog output, a milliamp meter is required.



NOTE:

TOTALIZER keeps track of water meter pulses. Totalizer will count even if the system is not in pulse timer feed mode and a water meter with a contact head is connected.



!!WARNING!!

CONTROLLER COULD BE DAMAGED AND VOID WARRANTY!

Analog outputs are self powered. Do not try to externally loop power.

Externally powered outputs will damage your controller!



TIP:

For help with menu locations, please refer to the 'Menu Map' supplied with your controller.

Calibration

Note: LO = 4 mA
HI = 20 mA

1. Remove signal wires if installed and connect a milliamp meter to output connections on daughter board. Observe proper polarity (+/-). Refer to Diagram 7, pg. 29, for connections.

Note: The Diagram reflects a dual or 2 channel board, if only one 4-20 mA is present (depending on your MB9200 Series model) there will be connections for one output.

2. SCROLL to **CONFIGURE-D/A OUT SELECT** under the **MAIN MENU-CONFIGURE** menu. Press ENTER.

3. **D/A OUT #1 PARAM-SYS COND** will be displayed. If more than one analog output is present, use the ARROW keys to display the analog input to be tagged to analog output. Present analog input is designated by an asterisk (*). Press ENTER.

4. Press ENTER and SCROLL DOWN to **LO ADJUST**. As indicated on the display, use the ARROW keys to calibrate the “lo” mA reading (4 mA) on the external milliamp meter. Press ENTER to enter the adjustment.

5. SCROLL DOWN to **HI ADJUST**. As indicated on the display, use the ARROW keys to calibrate the “hi” mA reading (20 mA) on the external milliamp meter. Press ENTER to enter the adjustment.

6. If controller is equipped with the analog output option, SCROLL DOWN to **LO RANGE**. As indicated on the display, use the ARROW keys to set the “lo range” set point. Press ENTER to enter the adjustment. SCROLL DOWN to **HI RANGE**. As indicated on the display, use the ARROW keys to set the “hi range” set point. Press ENTER to enter the adjustment.

7. Press SCROLL DOWN for additional analog outputs to be set, or press HOME repeatedly to return to **MAIN MENU-CONFIGURE**.

8. Remove milliamp meter and connect analog recorder, metering pump or computer. Be sure to maintain proper polarity when connecting external devices!

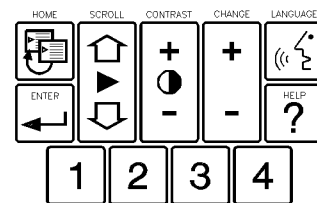

Configure
D / A Out Select

D / A out #1 param
* sys cond

D / A #1 lo adjust
ARROWS to change

D / A #1 hi adjust
ARROWS to change

D / A #1 lo range
0 us/cm

D / A #1 hi range
5000 us/cm

K) Set ALARM OUTPUT RELAY, ALARM DRY CONTACT

The controller provides an alarm relay output of line voltage which can activate an alarm or other device.

It also provides an alarm dry contact which can be interfaced with a computer or energy management system. Make electrical connections for Alarm Dry Contact on terminal strip J1 as follows (refer to Diagram 3, Relay Board, pg. 24 for connections):

- Connection 1 Relay Common A1
- Connection 2 N.O. A2
- Connection 3 Relay Common B1
- Connection 4 N.O. B2



TIP:

For help with menu locations, please refer to the 'Menu Map' supplied with your controller.



NOTE:

If duplicate functions are present, a number designation will be displayed with the alarm conditions.

For example: 'high alarm 1' and 'high alarm 2'.



NOTE:

Set 'Track' or 'Independent' Set point in the MAIN MENU-CONFIGURE menu.

The MB9200 Series allows the user to program which alarms will activate the alarm output. This can be accomplished in the SYSTEM CONFIGURE menu under **CONFIGURE-ALARM RELAY SEL.**

Continue by configuring the controller alarm relay output functions. SCROLL UP or SCROLL DOWN to **MAIN MENU CONFIGURE**

1. SCROLL DOWN to **CONFIGURE-ALARM RELAY SEL** under the **MAIN MENU-CONFIGURE** menu. Press ENTER.
2. **ALARM RELAY SEL-HIGH ALARM** will display. Press ENTER and an asterisk (*) will appear or disappear. The asterisk (*) indicates that the alarm condition will activate output.
3. Use the ARROW keys to display other alarm conditions to be activated or deactivated. Press HOME to return to **CONFIGURE-ALARM RELAY SEL.**

L) View VERSION NUMBER

This selection allows the user to determine the version of software installed in your controller.

1. SCROLL DOWN to **CONFIGURE-VERSION NUMBER** under the **MAIN MENU-CONFIGURE** menu. Press ENTER.
2. Present version number will display on your screen. Press HOME repeatedly to return to **MAIN MENU-DISPLAY DATA.**

SET POINTS AND ALARMS

Rising or Falling Set Point

The Rising or Falling Set Point is the setting at which the controller activates an output, such as a solenoid valve when the conductivity set point is exceeded.

1. Press SCROLL UP or SCROLL DOWN until **MAIN MENU-SET PTS & ALARMS** is displayed. Press ENTER.
2. **SET POINT 1** and the factory setting or the last set point entered will be displayed flashing on the second line. Use the ARROW keys to set the desired set point, press ENTER.

High or Low Alarm Settings

Every analog input has a high/low alarm indicator. The alarms can be configured one of two ways. The controller is factory configured to track the set point. An alarm offset is entered which sets the alarm point above and below the set point of the controller. Example: With an "ALARM OFFSET" of 200, if the set point is 1200, the high alarm would be at 1400 and the low alarm at 1000. The high/low alarms can also be configured with independent set points for the "High Alarm" and the "Low Alarm". This is accomplished through CONFIGURE-HI/LO ALARM under the **MAIN MENU-CONFIGURE** menu.

3. (If "track set point" was selected during the system configure procedure, skip steps 5 and 6) SCROLL DOWN to **ALARM OFFSET 1**. The factory setting or the last alarm offset entered will be displayed flashing. Use the ARROW keys to set the desired alarm offset, press ENTER.

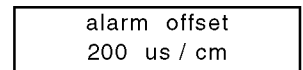
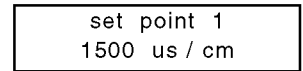
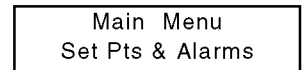
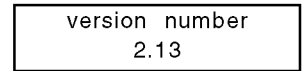
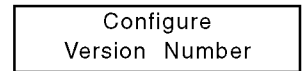
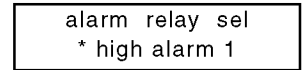
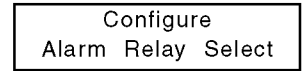
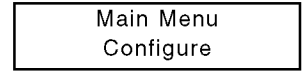
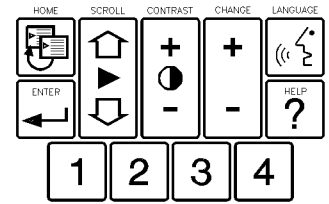



TIP:

For help with menu locations, please refer to the 'Menu Map' supplied with your controller.

4. Press **SCROLL DOWN** to display **HIGH ALARM 1** value and press **SCROLL DOWN** again to view **LO ALARM 1** value. No settings can be made if “track set point” was selected.

high alarm 1
1700 us / cm

lo alarm 1
1300 us / cm

5. (If “independent set point” was selected during the system configure procedure) **SCROLL DOWN** to **HIGH ALARM 1**. The factory setting or the last high alarm entered will be displayed flashing. Use the **ARROW** keys to set the desired high alarm setting, press **ENTER**.

high alarm 1
1600 us / cm

6. **SCROLL DOWN** to **LO ALARM 1**. The factory setting or the last low alarm entered will be displayed flashing. Use the **ARROW** keys to set the desired low alarm setting, press **ENTER**.

lo alarm 1
1000 us / cm

Set Point Differential

Also referred to as dead band or hysteresis. This is the offset applied to a set point to prevent chattering of an output relay around a set point.

7. **SCROLL DOWN** to **SET POINT DIFF 1**. The factory setting or the last set point differential entered will be displayed flashing. Use the **ARROW** keys to set the desired differential, press **ENTER**.

set point diff
100 us / cm

8. If your unit is equipped with a second boiler controller, repeat step 2, **SCROLL** to **SET POINT 2**, and repeat steps 3 through 7 and proceed with steps 9 and 10.

Timed Sample

A programmable timer. Programmed to open a blowdown valve for an operator set sample time. The sample duration is adjustable in one second increments up to 59 minutes and 59 seconds. The intervals between samples is adjustable in on minute increments up to 23 hours and 59 minutes. If the solids are less than the set point, the valve will close until the next sample time. If the solids are above the set point, the controller holds the valve open until the boiler has blowdown enough to reduce conductivity (solids) below the set point.

9. **SCROLL DOWN** to **SAMPLE INTERVAL**. The factory setting or the last interval programmed will be displayed flashing. Use the **ARROW** keys to set the desired interval and press **ENTER**.

sample interval
01:00 us / cm

10. **SCROLL DOWN** to **SAMPLE DURATION**. The factory setting or the last duration programmed will be displayed flashing. Use the **ARROW** keys to set the desired interval for minutes and seconds and press **ENTER**.

sample duration
01:00m:s 00:30

In order to facilitate optimum performance on RTD based conductivity measurement, sufficient sample duration is required to enable line/sample temperature to increase in common with boiler operation. Recommend minimum of 2 minutes.

NOTICE:

'Sample Interval' is displayed if the Sample Mode was configured for 'timed sample'. If not skip steps 9 and 10.



NOTE:

When configuring Inhibitor Feed Timer in System Configure menu, you may select only one of the modes present.



NOTE:

If multiple timers have been installed on your controller (Option C's), SCROLL DOWN would allow you to move from Timer 1 to Timer 2. Press the ENTER key to select the timer you are prompted to set.

SELECTABLE INHIBITOR FEED TIMER

The inhibitor feed timer is selectable. The user can choose one of four timer modes to base the addition of inhibitor. The selection of timer modes is made in **MAIN MENU-CONFIGURE**. *Only* the “Inhibitor Feed Mode” selected will be displayed in **MAIN MENU-INH FEED SET** menu.

Note: Refer to the following timer mode instructions for the mode you have selected.

Feed Limit Timer

Also referred to as lock-out timer. The chemical feed pump is actuated based on conductivity, simultaneously with blowdown. The timer limits the length of time the pump can be activated during any single bleed cycle, preventing overfeeding that could occur if the blowdown line were clogged. The timer is adjustable in 1 minute increments up to 23 hours and 59 minutes with an elapsed time display.

1. SCROLL UP or SCROLL DOWN through the displayed main menus to **MAIN MENU-INH FEED SET**. Press ENTER.
2. **INH FEED MODE-LIMIT TIMER** will be displayed.
3. SCROLL DOWN to **FEED LIMIT TIME**. The display will prompt you to enter the hours and minutes with the ARROW keys, press ENTER after each selection.
4. Press HOME key repeatedly to return to **MAIN MENU-DISPLAY DATA**.

Main Menu
Inh Feed Set

inh feed mode
limit timer

feed limit time
00:00 h:m 10:00

Post Blowdown Percent Timer '% post blowdown'

The timer is adjustable in 1 percent increments up to 100 percent of the blowdown time. The timer keeps track of the total blowdown time and activates the chemical feed when the blowdown deactivates for the percent of total blowdown time set.

1. SCROLL UP or SCROLL DOWN through the displayed main menus to **MAIN MENU-INH FEED SET**. Press ENTER.
2. **% POST BLEED** will be displayed.
3. SCROLL DOWN to **% OF BLEED FEED**. The display will prompt you to enter the desired percentage with the ARROW keys, press ENTER.
4. Press HOME key repeatedly to return to **MAIN MENU-DISPLAY DATA**.

Main Menu
Inh Feed Set

inh Feed Mode
% post bleed

% of bleed feed
0 %

Adjustable Percent Cycle Timer

Also referred to as cycle timer. The timer runs continuously on an adjustable time (minute) cycle, with the outputs being activated for an adjustable percentage of the time cycle. The timer is adjustable in 1 percent increments up to 100 percent of the cycle time.

1. SCROLL UP or SCROLL DOWN through the displayed main menus to **MAIN MENU-INH FEED SET**. Press ENTER.
2. **INH FEED MODE-PERCENT TIMER** will be displayed.
3. SCROLL DOWN to **PERCENT ON**. The display will prompt you to enter the desired percentage with the ARROW keys, press ENTER.
4. SCROLL DOWN to **% OF MINUTES**. Use the ARROW keys to enter the amount of time the timer will cycle, press ENTER. (Example: 10 minute percent timer set at 50% will be on for five minutes, off for five minutes.)
5. Press HOME key repeatedly to return to **MAIN MENU-DISPLAY DATA**.

Main Menu
Inh Feed Set

inh feed mode
percent timer

percent on
0 %

% of minutes
10 minute(s)



NOTE:

The Pulse counter will store one (1) overlapping pulse if received while pumping.



!!WARNING!!

If 'ACC SET' is entered as zero (0), the pulse timer will run continuously.



NOTE:

Pulse count may also be read in the INHIBITOR FEED SET main menu if system is configured for pulse timer.



TIP:

For help with menu locations, please refer to the 'Menu Map' supplied with your controller.



!!WARNING!!

Boiler system water is extremely hot and under pressure. Use extreme care when removing or installing conductivity probe!

Pulse Timer/Accumulator

Also referred to as water meter timer or reset timer. The timer accepts pulses from a water meter to actuate a chemical feed pump. The timer has an adjustable feed time "RUN TIME" in 1 second increments up to 59 minutes and 59 seconds with an elapsed time display. The timer has a built in accumulator "ACC CT/ACC SET" that can count pulses up to 255 before activating output with an elapsed pulse counter. Also incorporated into the timer is a pulse totalizer "COUNT TOTALIZER" that keeps an ongoing count of the number of pulses received by the timer. This pulse totalizer can be reset to 0 or any other number. This is accomplished in the Configure menu.

1. **SCROLL UP** or **SCROLL DOWN** through the displayed main menus to **MAIN MENU-INH FEED SET**. Press **ENTER**.
2. **INH FEED MODE-PULSE TIMER** will be displayed.
3. **SCROLL DOWN** to **RUN TIME**. The display will prompt you to enter the minutes and seconds with the **ARROW** keys. Press **ENTER** after each selection.
4. **SCROLL DOWN** to **ACC CT/ACC SET**. The number of pulses desired will be displayed flashing. Enter the number of pulses desired to activate timer with the **ARROW** keys, press **ENTER**. The present number of pulses, **ACC CT** (accumulation count), received is displayed to the left of the **ACC SET** entry.
5. **SCROLL DOWN** to **COUNT TOTALIZER** to read total pulses received from water meter. This number multiplied by gallons per contact of the water meter equals the total gallons used. This can be reset from **MAIN MENU CONFIGURE**.
6. Press **HOME** key repeatedly to return to **MAIN MENU-DISPLAY DATA**.

Main Menu
Inh Feed Set

inh feed mode
pulse timer

run time
00:00 m:s 00:30

acc ct / acc set
0 10

count totalizer
0

5. SYSTEM CALIBRATION

Important: Verify calibration before proceeding with final system start-up. Make sure probes are clean (refer to Section 10, Maintenance, pg.34) before proceeding with system calibration.

BOILER CONDUCTIVITY CALIBRATION NOTES

1. When reading or calibrating the conductivity of a boiler controller there must be an active sample flowing by the sensor. In the case of a timed sample system, the blowdown valve must be open long enough to have raised the temperature of the sensor to that of the sample.
2. Always compare an un-neutralized sample to the boiler controller, because changes in pH will affect the conductivity; a neutralized sample will not reflect this change due to pH, but the conductivity controller will reflect this change as it is an un-neutralized sample.
3. One point calibration assumes "zero" for the low calibration solution.
4. Two point calibration can be accomplished by opening the flush valve located below the sensor and then closing the full-port gate valve upstream of the sampling electrode (refer to Figure 1, pg. 5). This should prevent the flow of water across the sensor creating zero (0) conductivity for low cal setting.

5. Obtain a sample of system water from the surface blowdown line and test the sample with a reliable tester. If a non-temperature compensated tester is used, manually compensate or cool the sample to 25°C (77°F) and read the conductivity of the sample. If temperature compensated tester is used, be sure to follow temperature restrictions as indicated by handheld manufacturer. If the tester and the controller agree, proceed with programming parameters; if not, proceed with system calibration.

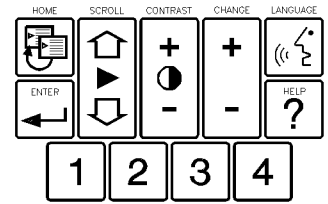

NOTE:

In all cases, you must select either SW1-1 or SW1-3.

Information on Conductivity Daughter Board switch functions

(Refer to Diagram 5, pg. 26.) Switches 1-4, on the SW1 and SW3 switch blocks, have the following functions:

- SW1-1: Cell Constant Selection
- SW1-2: Cell Constant Selection
- SW1-3: Cell Constant Selection
- SW1-4: Disable/Enable Temperature Compensation
Open (Up/Off) for Non-Temperature Compensated Probe
Closed (Down/On) for Temperature Compensated Probe

Diagram 5, pg. 26, shows the factory default setting. It is configured for standard probe calibration with a temperature compensated carbon graphite probe.

General Calibration Procedure

1. SCROLL UP or SCROLL DOWN through the displayed main menus to **MAIN MENU-CALIBRATE SENSOR**. Press ENTER.
2. **CALIBRATE SENSOR-SYS COND** will be displayed. (**SYS COND 1** will be displayed also if your controller is equipped with Option E, Second Boiler Controller. **SYS COND 2** would be found by pressing the SCROLL DOWN key) Press ENTER.
3. **SYS COND CAL-1 POINT* 2 POINT** will be displayed. Use the ARROW keys to select 1 (proceed to step 4) or 2 (go to step 5) point calibration. The asterisk (*) is shown next to the chosen selection. Press SCROLL DOWN.
4. If 1 point calibration was chosen, **SYS COND HI CAL-0 US/CM** will be displayed. Use the ARROW keys to enter the value of the calibration solution. Press ENTER. Then press the HOME key repeatedly to return to **MAIN MENU-DISPLAY DATA**.
5. If 2 point calibration was chosen, **SYS COND LOW CAL-0 US/CM** will be displayed. Use the ARROW keys to enter 0 or the value of the low calibration solution. Press SCROLL DOWN.
6. **SYS COND HI CAL-0 US/CM** will be displayed. Use the ARROW keys to enter the value of the high calibration solution. Press ENTER. Then press the HOME key repeatedly to return to **MAIN MENU-DISPLAY DATA**.



NOTE:

LO μ S/CM is displayed only if 2 point calibration is chosen. This step is not required for 1 point calibration.

Main Menu
Calibrate Sensor

Calibrate Sensor
sys cond

sys cond cal
1 point* 2 point

sys cond hi cal
0 us / cm

sys cond lo cal
0 us / cm

sys cond hi cal
0 us / cm

6. DIAGRAMS: INSTALLATION, COMPONENT, AND ELECTRICAL

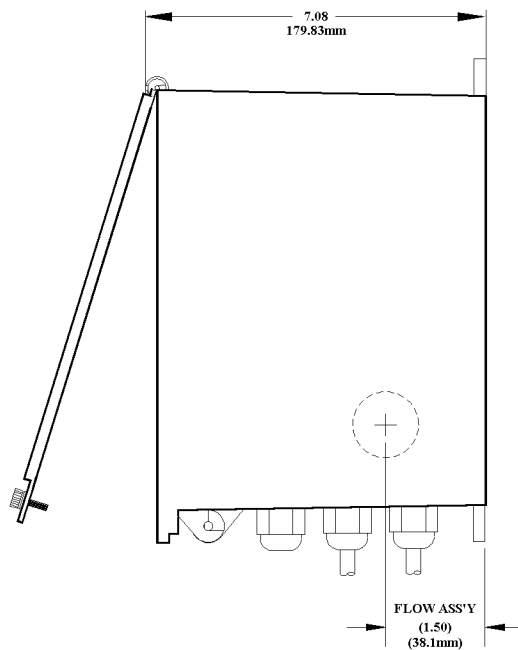
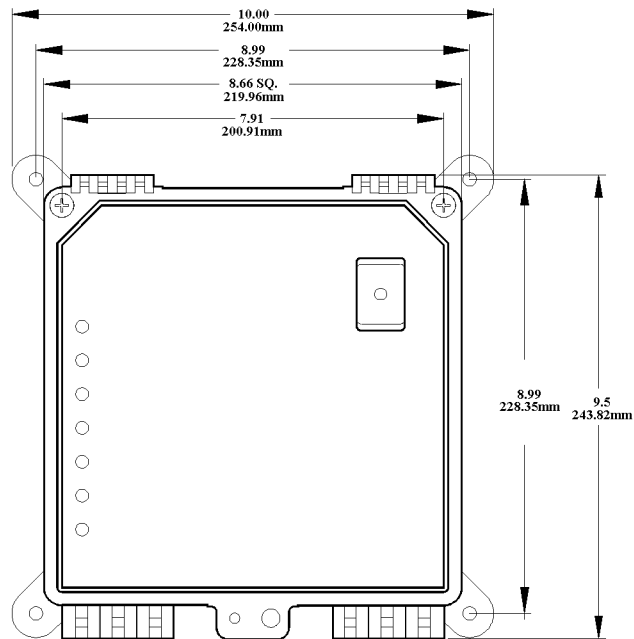

DIAGRAM 1 DIMENSIONAL DATA

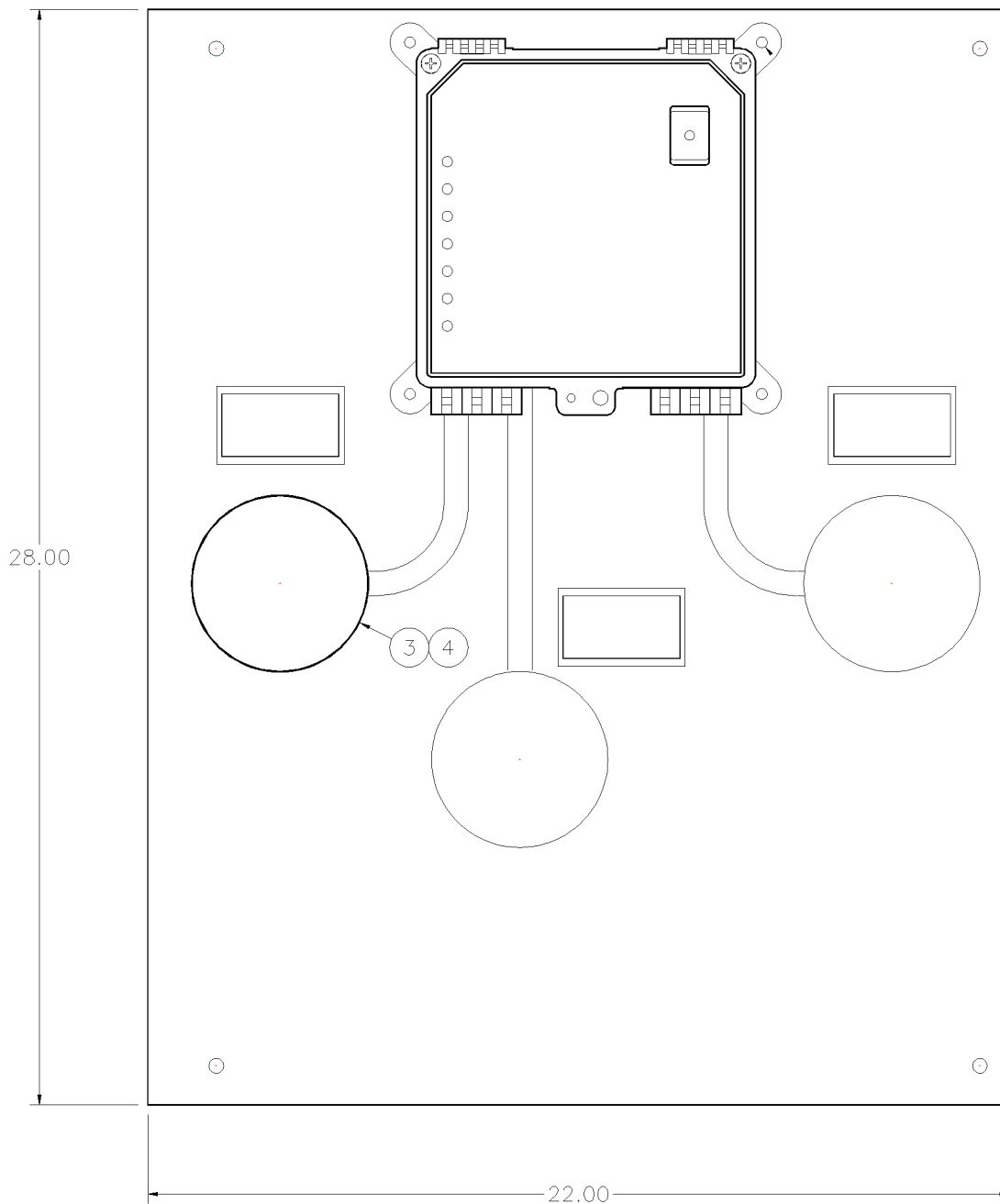
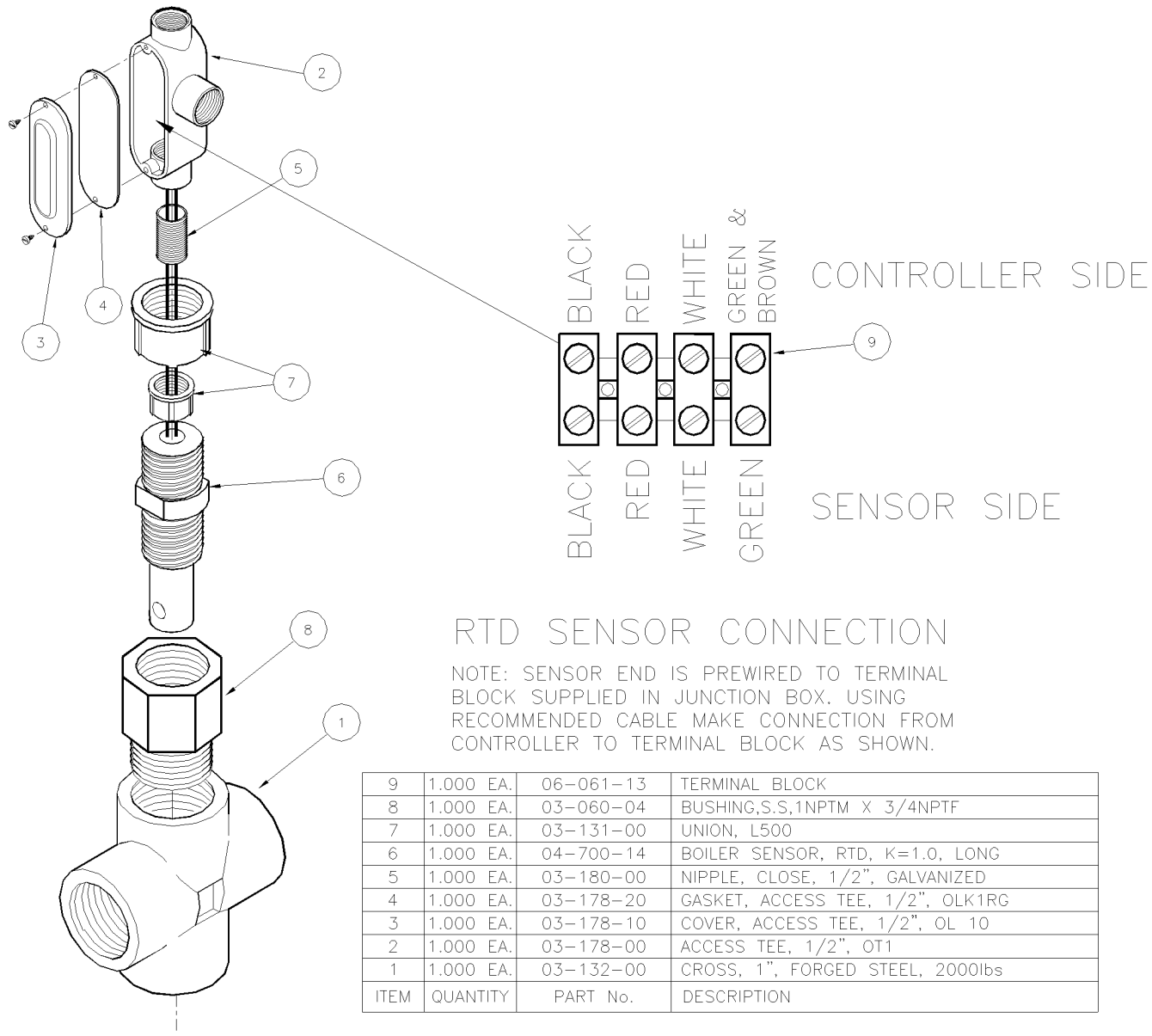

DIAGRAM 1A DIMENSIONAL DATA (UNITS WITH PANEL MOUNT OPTION)



SPECIFICATIONS

- Pressure Rating250PSI (17.3 BAR)
- Temperature Rating392°F (200°C)
- Thread Size.....1" (2.5 cm) NPT
- ConstructionStainless Steel, Ryton
- Cell Constant1.0
- Wiring.....Fitting for 1/2" (1.3 cm) Conduit

DIAGRAM 2 CBN-1 ELECTRODE

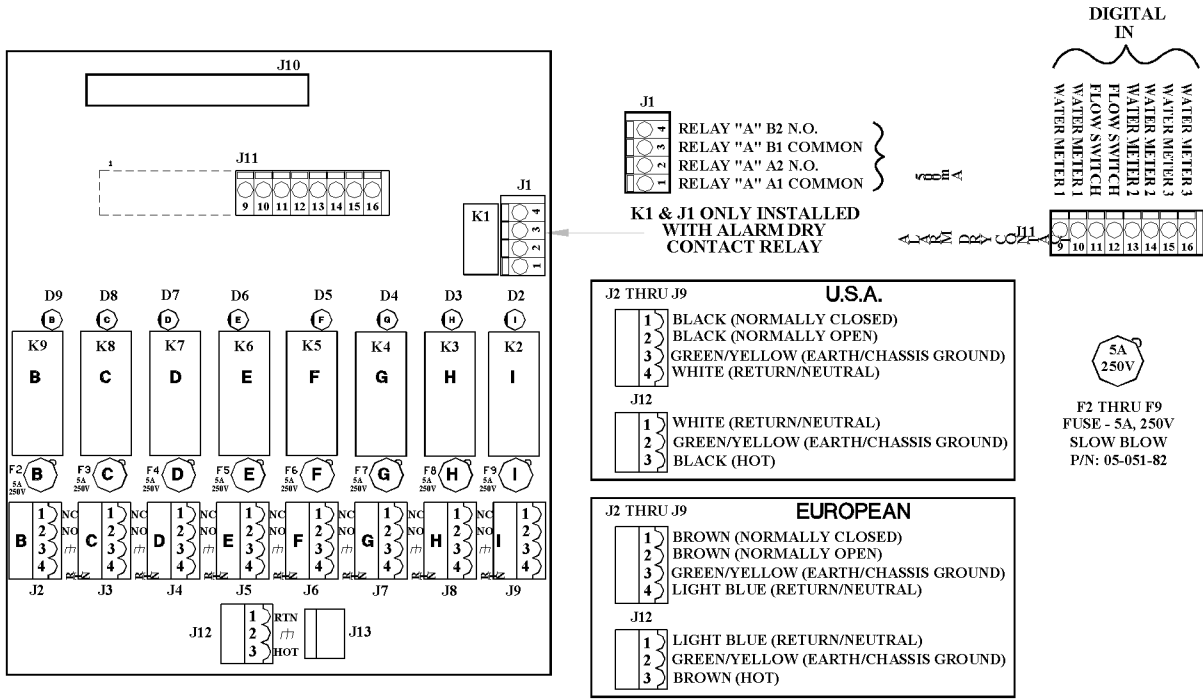

CURRENT VERSION

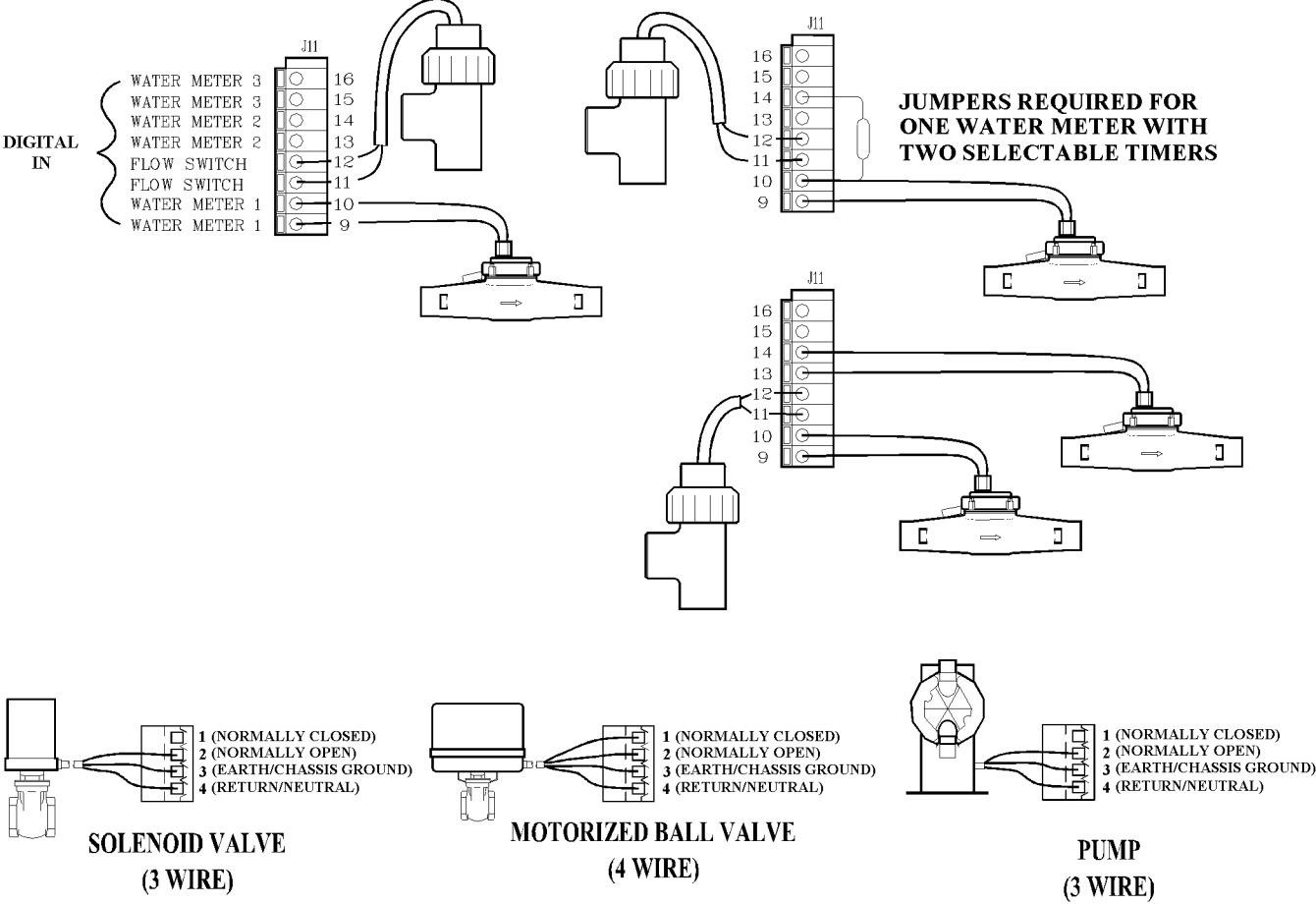

DIAGRAM 3 POWER SUPPLY/RELAY BOARD

Conduit units are factory predrilled with easily accessible terminals for hard wiring. See Relay Board, Diagram 3, pg. 25, and Electrical Wiring section in this manual, pg. 7.

NOTE: Use only 16 or 18 AWG wire for conduit power and load connections. Never run power and signal wiring together in same conduits. (Example: Sensor Outputs with Power wiring)

Model	Front Panel Relay #1	Front Panel Relay #2	Front Panel Relay #3	Front Panel Relay #4
921__X____	Boiler #1 Blowdown	Timer #1	(N/A)	(N/A)
921__A____	Boiler #1 Blowdown	Timer #1	Timer #2	(N/A)
922__X____	Boiler #1 Blowdown	Boiler #2 Blowdown	Timer #1	(N/A)
922__A____	Boiler #1 Blowdown	Boiler #2 Blowdown	Timer #1	Timer #2

The chart above indicates the function of the relay on the front panel.

DIAGRAM 4 CONDUIT WIRING TABLE

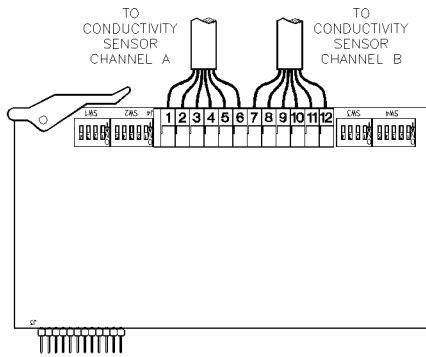

CHANNEL A CHANNEL B

J4-1 = BLACK J4-7 = BLACK
 J4-2 = RED J4-8 = RED
 J4-3 = WHITE J4-9 = WHITE
 J4-4 = GREEN J4-10 = GREEN
 J4-5 = BROWN J4-11 = BROWN
 J4-6 = SHIELD J4-12 = SHIELD

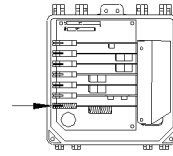

RTD CARD CONDITION INDICATORS	
LED FLASHES	INDICATION
1	CARD RESETTING
2	RTD FAILURE
3	CARD SATURATION or CARD FAILURE
4	CONDUCTIVITY OVER SELECTED RANGE

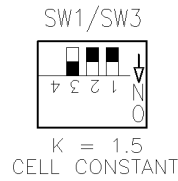
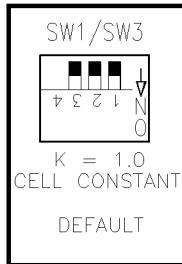
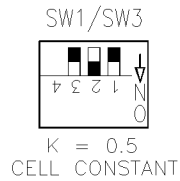
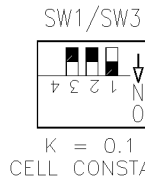
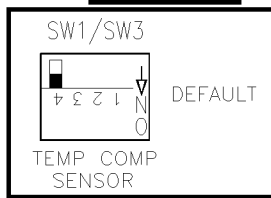
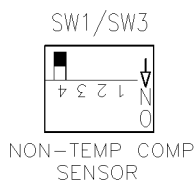
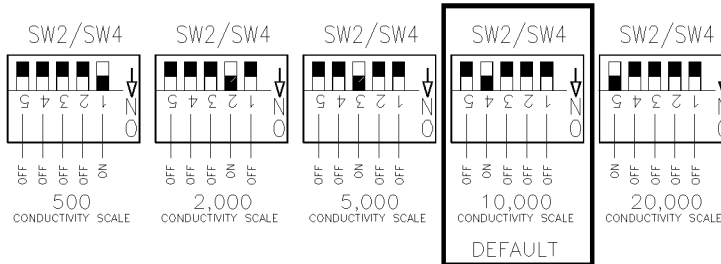
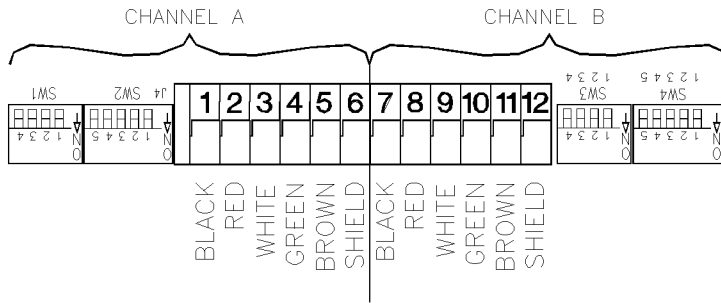
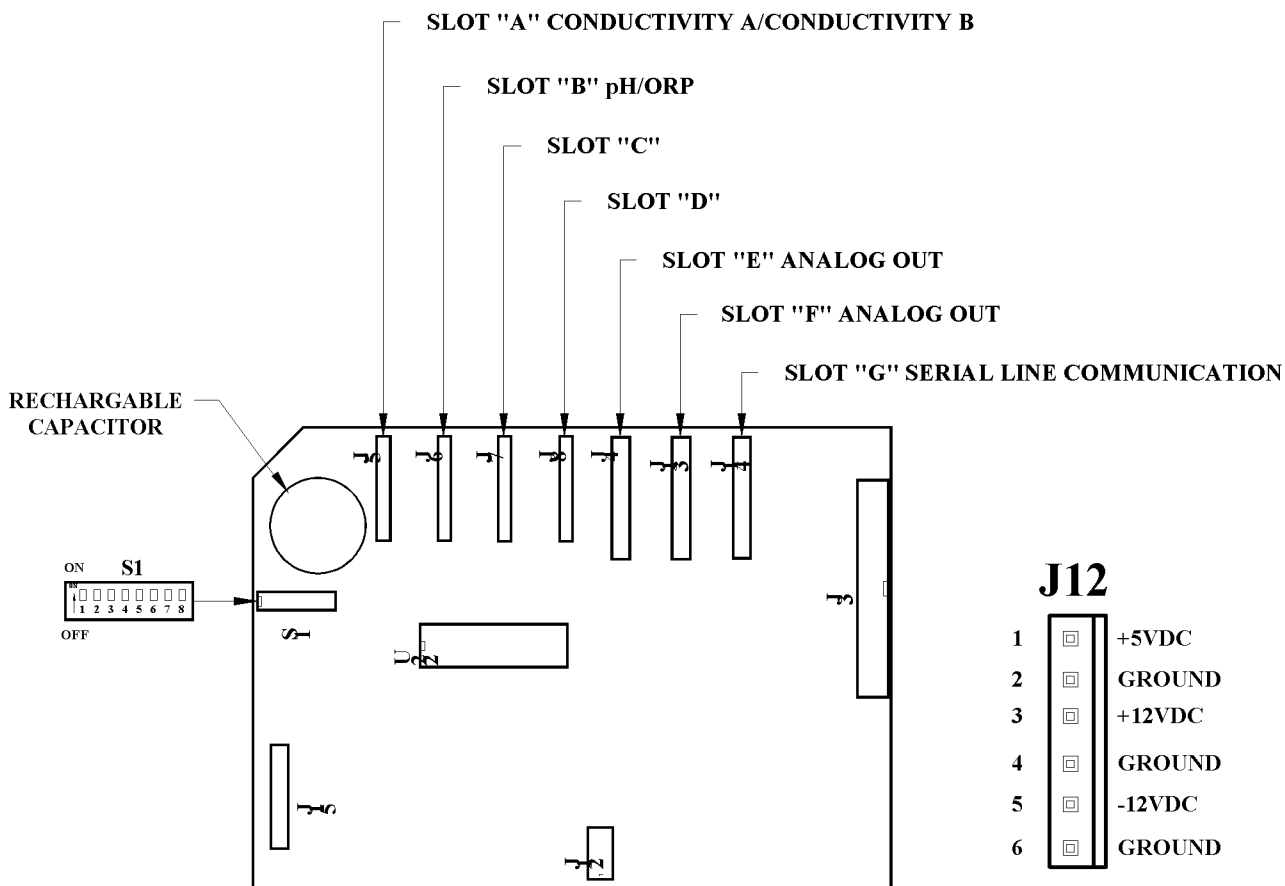

DIAGRAM 5 CONDUCTIVITY DAUGHTER BOARD

ANALOG SIGNAL DAUGHTER BOARD SLOT LOCATIONS, IF CONTROLLER IS SO EQUIPPED



J12

1	<input type="checkbox"/>	+5VDC
2	<input type="checkbox"/>	GROUND
3	<input type="checkbox"/>	+12VDC
4	<input type="checkbox"/>	GROUND
5	<input type="checkbox"/>	-12VDC
6	<input type="checkbox"/>	GROUND

"S1" DIP SWITCH SETTINGS		
POS	"ON"	"OFF"
1	N/A	N/A
2	FLOW SWITCH ENABLE	N/A
3	N/A	N/A
4	N/A	N/A
5	N/A	N/A
6	N/A	N/A
7	N/A	N/A
8	N/A	N/A

DIAGRAM 6 MOTHER BOARD

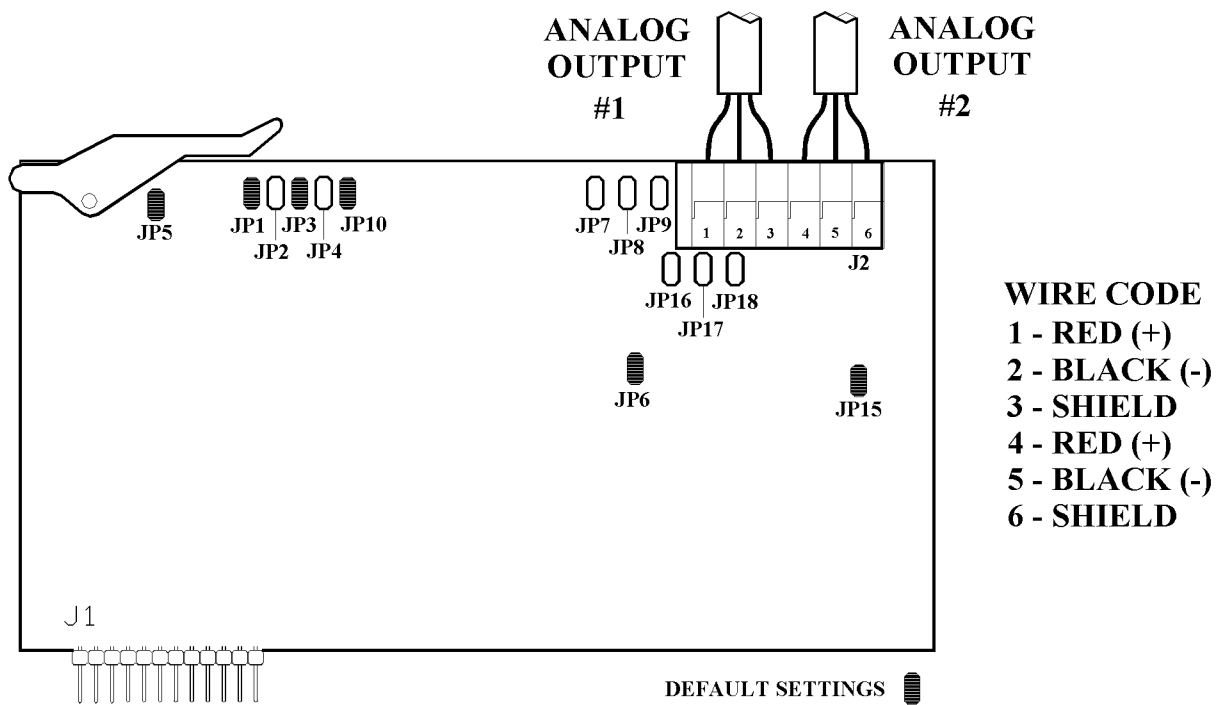

SINGLE CHANNEL (08-600-13)

CHANNEL 1	JP1	JP2	JP5	JP6	JP7	JP8	JP9
0-1mA		X					
0-20mA	X						
*4-20mA	X		X	X			
0-2V	X				X		
0-5V	X					X	
0-10V	X						X

* DEFAULT SETTING

DUAL CHANNEL (08-600-12)

CHANNEL 2	JP3	JP4	JP10	JP15	JP16	JP17	JP18
0-1mA		X					
0-20mA	X						
*4-20mA	X		X	X			
0-2V	X				X		
0-5V	X					X	
0-10V	X						X

* DEFAULT SETTING

DIAGRAM 7 DAUGHTER BOARD - ANALOG OUTPUTS

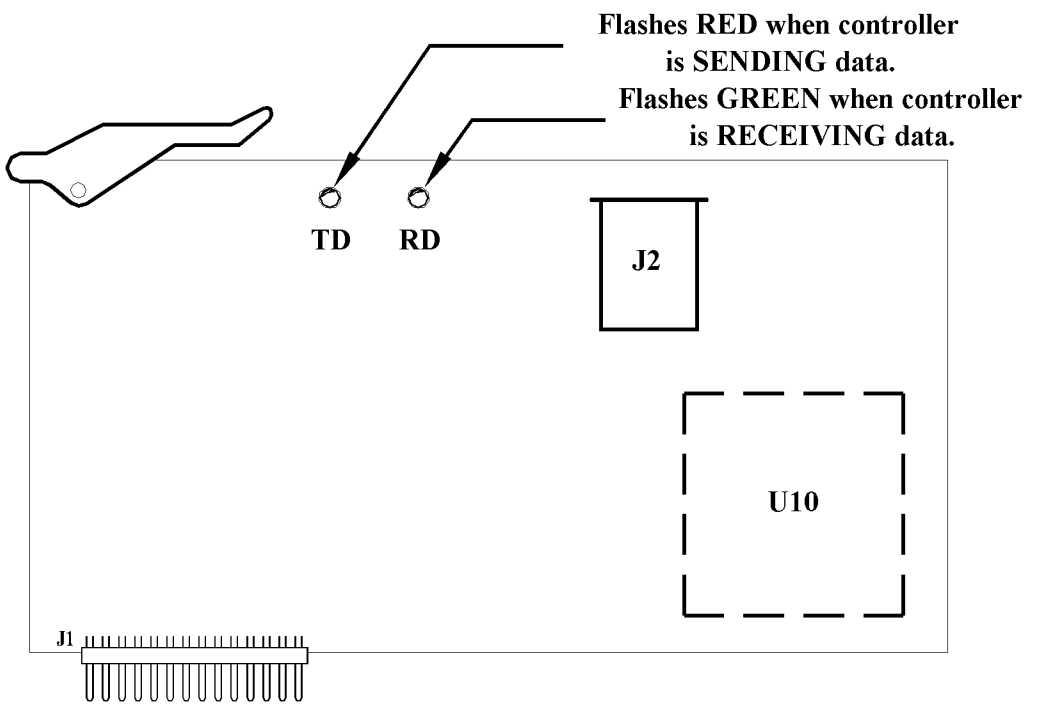
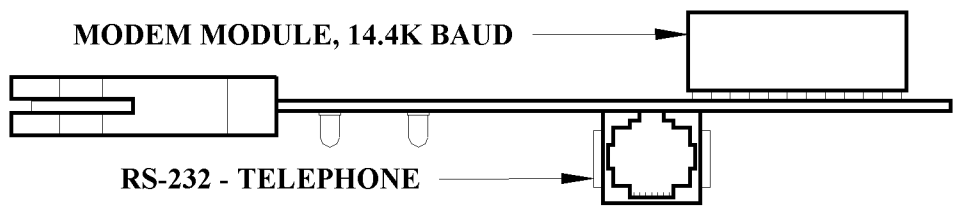

EUROPEAN SERIAL LINE COMMUNICATION DAUGHTER BOARD

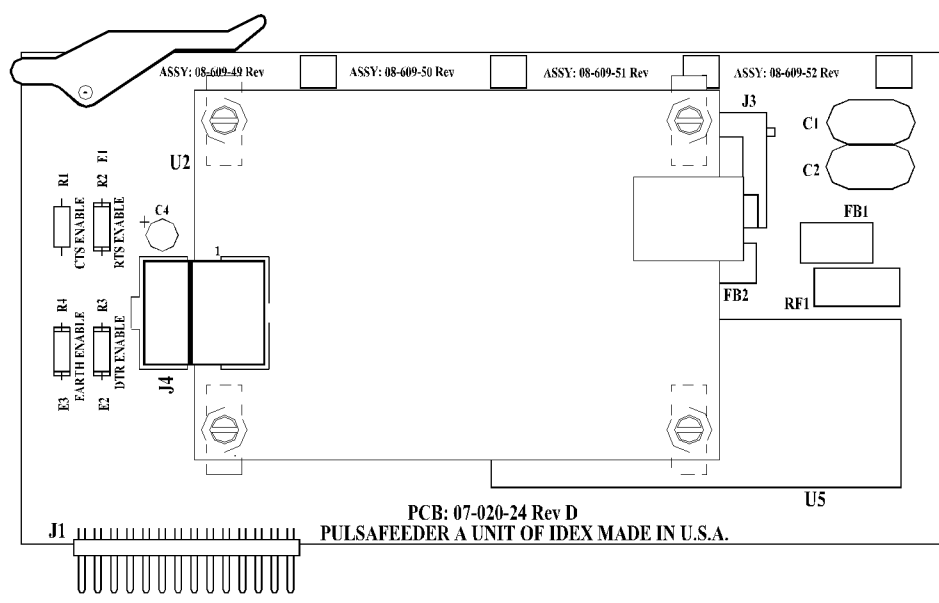

DIAGRAM 7A DAUGHTER BOARD - SERIAL COMMUNICATIONS

7. SPECIFICATIONS (Factory settings are default values)

GENERAL

Power Input	90/250VAC @ 50/60 Hz 100 VA.
Control Output	Line voltage @ 600 VA (5 amps @ 115 VAC) per relay.
Enclosure Conduit	High impact resistant polystyrene designed to NEMA 4X, factory predrilled with easily accessible terminals for hard wiring.
Display	Alphanumeric 2 line by 16 character lighted LCD display.
Power Switch	Recessed front panel.
H/O/A Switches	Front panel keypad.
Contrast Adjustment	Front Panel keypad.
Bilingual	English and Spanish standard.
Lockable Viewing Window	Standard
Security Code	Standard
Environment	Ambient temp. 0°F (-17.8°C) to 122°F (50°C); relative humidity 0 to 95%.
Dimensions	
Controller Weight	
Shipping Weight	
Inputs	2 analog and 2 digital
Outputs	2 analog and 4 relays

BOILER CONDUCTIVITY

Electrode	CBN-1 rated @ 250 psi (17.3 BAR) @ 392°F (200C).
Set Point	Rising set point. Factory setting @ 1500 µS/cm.
Range	Selectable 0 to 500, 2000, 5000, 10,000 & 20,000. Factory set @ 5000 µS/cm.
Accuracy	+/- 1% of full scale, at point of measurement, excluding electrode.
Differential	Adjustable. Factory setting @ 100 µS/cm.
High/Low Alarm	Adjustable. Select follow set point or independent set of HIGH and LOW, factory set track set point @ +/- 200 µS/cm.
Selectable Sample Mode	Continuous or timed sample, factory set timed sample mode. Adjustable interval between samples (1 min. to 23 hr. 59 min.), factory set @ 30 minutes. Adjustable duration of sample (15 sec. to 5 min.), factory set @ 1 minute.

SUMMARY OF KEYPAD

Home	When pushed, returns display back one level in menu structure.
Enter	When pushed, enters displayed variable or value.
Scroll Up	Used to scroll-up through (view) menu and to display variables.
Scroll Down	Used to scroll-down through (view) menu structure.
Contrast Keys	Used to control contrast of viewing screen.
Arrow Keys	Used to move between variables and to increase/decrease numerical settings.
Language	Used to select one of the two onboard languages.
Help	Used to display information about present displayed menu level.
Relay Keys	Hand/Off/Auto (HOA) switches, depressing key: ONCE - Forces corresponding output relay on for five minutes; LED color amber. TWICE - Forces corresponding output relay off indefinitely; LED color red. THREE times - Returns control to automatic; LED off if within set point, green if out of set point.

SUMMARY OF LED INDICATOR LIGHTS

Power Indicator	Illuminates when power is supplied to unit.
Alarm Indicator	Flashes red when an alarm condition is present.
Relay Indicators	AMBER if forced on. RED if forced off. OFF if in auto mode and control function is not automatically activated. GREEN if activated automatically.

8. FACTORY DEFAULT VALUES

NOTE: Your controller may not include all of these features

SYSTEM CONDUCTIVITY SCALE	5000 μ S/cm					
High Alarm	1700 μ S/cm					
Low Alarm	1300 μ S/cm					
Set Point	1500 μ S/cm rising					
Set Point Differential	100 μ S/cm					
Alarm Offset	200 μ S/cm					
SYSTEM pH SCALE	0-14 pH					
High Alarm	9.40 pH					
Low Alarm	5.40 pH					
Set Point	7.40 pH rising					
Set Point Differential	0.20 pH					
Alarm Offset	2.00 pH					
Limit Timer	01:30 HH:MM					
SYSTEM ORP SCALE	0-1000 mV					
High Alarm	500 mV					
Low Alarm	300 mV					
Set Point	400 mV falling					
Set Point Differential	50 mV					
Alarm Offset	2100 mV					
MAKE-UP CONDUCTIVITY SCALE	2000 μ S/cm					
High Alarm	700 μ S/cm					
Low Alarm	500 μ S/cm					
Set Point Differential	0.40 CY					
INHIBITOR TIMER	Limit					
Feed Timer	10:00 HH:MM					
BIOCIDE TIMERS						
Week	No Week					
Day	Friday					
Start Time	00:00 HH:MM					
Run Time	01:30 HH:MM					
Bleed Lock Out Time	00:00 HH:MM					
Pre-Blowdown Time	00:00 HH:MM					
Conductivity Min	0 μ S/cm					
BOILERS						
Interval Time	01:00 HH:MM					
Duration Timer	00:30 MM:SS					
Sample Mode	Timed Sample					
MISCELLANEOUS						
Hi/Low Alarms	Tracking Set Point					
Display Dampener	1 Second					
POSSIBLE ALARMS						
All High Alarms	X					
All Low Alarms	X					
Limit Time pH	X					
Limit Time ORP	X					
No Flow	X					
Inhibitor Limit Timers	X					
OTHER INHIBITOR FEED MODES						
PULSE TIMER						
Run Time	00:30 MM:SS					
Accumulator Set	10					
Count Totalizer	1					
PERCENT TIMER						
Percent On	5%					
% of Minutes	10					
% OF POST BLOWDOWN						
% of Blowdown Feed	5%					
OTHER SCALES	Max Range	High Alarm	Low Alarm	Set Point	Set Pt. Diff.	Alarm Offset
0-500	500	200	100	150	20	50
0-2000	2000	700	500	600	40	100
0-10000	10000	3300	2700	3000	150	300
0-20000	20000	6600	5400	6000	200	600

9. TROUBLESHOOTING GUIDE

If your controller is not operating properly, proceed through the troubleshooting instructions below.

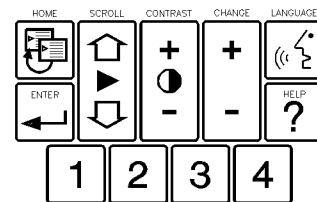

MOTHER BOARD

Symptom	Probable Cause	Possible Solution
Keypad Locked Up	Conductivity scale changed	Scroll down or scroll up after 15 seconds.
No Display (See Power Supply first)	Improper contrast	Adjust contrast on mother board. See Diagram 6, pg. 28.
	Environment exceeds 122°F (50°C)	Relocate controller.
Erratic Readings	Improperly grounded power	Assure power and ground integrity. Shields of all sensors should be connected at controller end only.

POWER SUPPLY BOARD

Symptom	Probable Cause	Possible Solution
No Power Light	Blown fuse	Replace fuse on Power Supply board.
	Interconnecting cables loose	Check connections.
	No power supplied	Check power source.
	Power switch off	Turn power switch ON.

RELAY BOARD

Symptom	Probable Cause	Possible Solution
No Outputs Each relay, on the Relay Board, has a fuse and a red LED	If the Output front panel LED is lit and the Relay board LED is not lit: <ul style="list-style-type: none"> • ribbon cable. 	Check ribbon cable connection or replace.
	If the Output front panel LED is lit and the Relay board LED is also lit: <ul style="list-style-type: none"> • blown fuse • bad relay 	Replace fuse, if necessary, or replace relay

BOILER CONDUCTIVITY

Symptom	Probable Cause	Possible Solution
Display Erratic with Solids High and Increasing	Steam in sample line; check the following <ul style="list-style-type: none"> • Surface skimmer not 4 to 6 inches below surface • Sample line not throttled 	Lower skimmer 4 to 6 inches below surface. Throttle sample line.
Front Panel Blowdown LED Cycles On and Off	Steam in sample line; check the following <ul style="list-style-type: none"> • Surface skimmer not 4 to 6 inches below surface • Sample line not throttled 	Lower skimmer 4 to 6 inches below surface. Throttle sample line.
Controller Stays In Blowdown and Solids Continue To Increase	Blowdown line throttled too much	Increase blowdown rate.
Conductivity of System Stays Lower Than Set Point, Never Or Rarely Blows Down	Uncontrolled blowdown If timed sampling: <ul style="list-style-type: none"> • Interval between samples too frequent for load • Duration too long for load 	Blowdown valve leaking. Try the following: <ul style="list-style-type: none"> • Realign ball valve. • Clean solenoid valve. • Close manual blowdown valve. Shorten sample period.
Conductivity of Controller Decreases While System Conductivity Increases	Fouled sensor	Clean sensor.

REINITIALIZATION

If the above troubleshooting steps fail to explain or solve condition, perform a factory reinitialization (see Initialization, pg. 9, and Diagram 6, pg. 28, Mother Board). If condition still exists, contact factory for customer service assistance at (1/800-333-6677). A Return Authorization (RA) number is required for any return.

10. MAINTENANCE

Maintenance on the MB9200 Series controller requires only that the operator periodically clean the electrode. It is recommended that you establish a regular maintenance schedule designed to meet the needs of your particular application. All other service should be performed by factory authorized personnel only. Modifications to or tampering with the circuit level components makes all warranties, written or implied, and/or manufacturer's responsibility for this controller null and void.

ELECTRODE INFORMATION

To remove an electrode from the skimmer blowdown line for cleaning and for reinstallation, keep the following in mind:

1. Remove power from the system.
2. Remove pressure from the system prior to unscrewing the electrode; to remove pressure, close isolation valve located before the electrode.
3. Open the flush valve to drain water from electrode. This will facilitate removal of electrode.
4. Remove electrode.
5. Reinstall electrode, paying attention to the direction of flow. The sensor flats should be perpendicular to the direction of flow.
6. Close flush valve.
7. Reapply pressure and flow by opening isolation valve slowly to avoid water hammer.
8. Reapply power to the system.
9. You may want to recalibrate sensor at this time.

Refer to Diagram 2, pg. 23, for information and specifications for electrodes supplied with your system.



!!WARNING!!

Use proper handling procedures including rubber gloves, eye protection and protective clothing, when handling any acid solution.

CLEANING THE ELECTRODE

1. Wipe the electrodes clean with a clean cloth.
2. Use a fine grain emery cloth for stubborn stains.
3. Oils can affect probe performance. Do not touch probe surface. The probe can be agitated in a mild solution of dish washing soap and water to remove oils transferred during handling.
4. Some fouled electrodes might require dipping in a mild solution of muriatic acid in order to remove fouling.

11. GLOSSARY

- Alarm Relay** an electric circuit when triggered by a predetermined signal will activate an externally connected alarm
- Analog** a device that represents in terms of physical variables, i.e. conductivity, pH, ORP
- Analog Recorder** a device such as a plotter that physically stores or presents quantities of data in a physical manner
- Auto Scroll** a function of the Controller which allows unit to automatically display system status, active alarms, time, date, etc.
- Biocide** an agent used to control the growth of algae and other organic substances
- Bleed** (or blowdown) to release cooling tower water from the system, used to control conductivity
- Blowdown** see Bleed
- Blowdown Valve** the valve that opens or closes to release water from the system activated by a signal from the Controller
- Buffer Solution** a solution with a specific pH value used as a control in calibrating probes and sensors
- Calibration** a procedure to match values “read” by probes and sensors to actual real world values
- CalKit** a kit available from the manufacturer with a specific cavity volume used to calibrate conductivity sensor
- Caustic** burning, corrosive, a characteristic of some chemicals especially strong alkalis
- Chattering** a situation that occurs when relay controlled device repeatedly turns off and on
- Chemical Feed Pump** a relay or proportionally controlled pump that disperses chemical into the system
- Chemical Metering Pump** see Chemical Feed Pump
- Conductivity** the ability of a substance to conduct electrical current, concentrations of dissolved and suspended matter in cooling tower water directly determine the conductivity of the water
- Configure** procedure to set up basic functions of the controller, i.e. date, time, set point control, etc.
- Contacting head water meter** a water meter that outputs a dry contact signal every time it pulses
- Contrast** difference in brightness between adjacent objects, i.e., darkness of text in screen display versus lightness of the screen background
- Cooling Tower** a structure of various sizes that allows heat to radiate away from the system water.
- Cycle Timer** a timing device that can be preset to turn off and on at specific intervals
- Daughter Board** an auxiliary circuit board within the controller dedicated to a specific function(s) of the controller
- Differential** also referred to as dead band or hysteresis, this is a range or offset applied to a set point value (see chattering)
- Dip Switch** very small switches located on the circuit boards usually used in combination with other dip switch settings
- Display Dampener** a setting in the System Configure menu that determines the number of samples that are averaged and the number of seconds before a new reading is displayed on the screen
- Double Junction** type of construction on a pH probe
- Dry Contact** relay contacts without power
- EEPROM** Electrically Erasable Programmable Only Memory
- Electrodes** or sensors, the metal protrusions that measure conductivity in the conductivity sensor assembly
- Conduit** hard wired
- Fish Paper** thin paper that is inserted between battery and battery clip to prevent battery drain during shipping or storage of controller
- Float Switch** a mechanical switch that shuts off fresh water supply to the cooling tower system when water level rises to a predetermined height
- Flow** refers to the movement of water through the system
- Flow Assembly** an option which attaches to the controller and incorporates a flow switch, sensor/probe ports, and sample valve
- Gate Valve** a type of on/off valve for controlling the flow of liquid
- GFPP** Glass Filled Polypropylene
- Ground Loops** unwanted stray electrical signals that adversely affect controller
- Heat Exchanger** a mechanical device which produces energy and is cooled by the flow of water in the cooling tower system
- HCl** Hydrochloric Acid
- Hi Lo Alarm** a function of the controller that signals the user when conditions exceed a predetermined high or low value
- History Files** information that is stored in the controller, (history files are lost if battery fails or is removed)
- HOA** abbreviation for Hands Off Auto
- HOA Switches** manual relay switches or keys (relay 1 - 6) located on the control panel of the controller
- Home** this key when pressed returns user to the previous menu displayed on the viewing screen, press repeatedly to return to the main menu
- Independent Set Point** this feature, when selected under HI LO ALARM in the System Configure menu, allows user to independently set the high and low alarm values
- Inhibitor** a chemical or compound used to aid the control of corrosion or scaling in the cooling tower system
- Inhibitor Feed** term referring to the dispersment of inhibitor in to the system
- Inhibitor Timer** a function of the controller which regulates the amount of time inhibitor is introduced to the system
- Initialization** a procedure to set up the starting condition of the controller
- Inorganic Scale Deposits** undesirable precipitate formations within the cooling tower system

- Inputs** receptacles or hookups for signals delivered to the controller
- (ISO) Isolation Valves** general term which refers to valves in the system used to isolate various components of the system from the main flow
- Jumper** a wire connector (shunt) that connects two points
- KCl** Potassium Chloride
- LED** abbreviation for Light Emitting Diode
- Limit Timer** also referred to as lockout timer or feed limit timer, it limits the amount of time output is activated
- Line Voltage** voltage equivalent to outside source voltage to the controller
- Lockout** intentionally preventing blowdown or other functions of the system
- Menu Map** printed document supplied with controller illustrating all menu item locations
- Metering Pump** see chemical feed pump
- Micro Siemens** unit of measure of conductivity expressed as uS/cm
- Mother Board** main circuit board located in controller
- NaOH** Sodium Hydroxide
- ORP** Oxidation Reduction Potential, measured in milliVolts (mV) to detect and control level of chlorine or other oxidizing agents in system water
- Outputs** receptacles or hookups for signals originated at the controller
- Overfeed** a condition in which the quantity of an ingredient dispersed into the system exceeds the amount desired
- Percent Post Blowdown** refers to the amount of time as a percentage of blowdown time that chemical feed pumps are activated when blowdown is deactivated
- Percent Timer** also referred to as a cycle timer that runs continuously that activates an output to run as a percent of total cycle time
- pH** the measurement of acidity or alkalinity (acid or base) of an aqueous solution
- Pre-Bleed** refers to the time bleed (or blowdown) is executed before biocide feed
- Pre-Blowdown** see Pre-Bleed
- Probe** also referred to as a sensor or electrode; a device connected to the controller which monitors or measures a value in the cooling tower flow stream
- Probeless Calibration** a calibration procedure used to test and verify operation of the controller
- Program Parameters** the user programmed settings that determine how the controller responds to the conditions of the cooling tower water
- Pulse** the action of a water meter that when equipped with a contact head, can generate a signal sent to the controller
- Pulse Timer** a feature of the controller in which a timer accepts pulses from a water meter to actuate a chemical feed pump
- Relay Board** a circuit board in the controller for relay outputs, water meter hookups, flow switch, etc.
- Relay Indicators** lights (LEDs) located beneath the relay keys on the face of the control panel that indicates the status of individual relays
- Sample Cock** see Sample Valve
- Sample Line** a line within the cooling tower flow where probes and other monitoring devices are located controlled with isolation valves
- Sample Stream Flow Assembly** an option (standard on many models) which is a modular assembly that mounts to the controller with quick-release probe(s), flow switch and sample cock or (valve)
- Sample Valve** small valve on the flow assembly that provides user a means to drain small quantities of water from the system for testing
- Scale/Range** the adjustable monitoring range of the controller in reference to conductivity levels in the system
- Security Code** a code that can be entered by the user when configuring the system to secure access to the controller settings
- Sensors** see Probe
- Set Point** the user determined value within a monitored range at which the controller initiates action
- Set Point Differential** also referred to as dead band or hysteresis; the offset applied to a set point to prevent chattering of an output relay around a set point
- Solenoid** an electromagnetically controlled switch
- Storage Boot** small protective rubber boot filled with a junction wetting agent found on the tip of a new pH or ORP probe to keep tip wet during shipment and storage
- System Overfeed** usually a malfunction condition where a feed pump fails shut off
- System Parameters** see program parameters
- System pH** level of pH in the system water
- TDS** abbreviation for Total Dissolved Solids, measured in terms of electrical conductivity(uS/cm)
- Temperature Compensation** displays conductivity as if measured at 25°C
- Temp Sensor** used to measure temperature
- Throttling** the act of adjusting a valve or other flow control device to vary flow volume
- Totalizer** a resettable function of the controller which keeps count of the number of water meter pulses
- Track Set Point** a function of the controller in which set point offset range is determined by set point value
- uS/cm** micro Siemens
- Water Hammer** a potentially damaging situation that occurs if a valve in the system is opened too quickly, where the action results in a “hammering” effect throughout the system water lines
- Y-Strainer** inline filter or screen to remove debris from system flow assembly

12. 9200 BOILER SERIES PRODUCT LINE UP

Our 9200 line of boiler controllers and monitors offer an easy, affordable way to meet your needs for versatile, accurate control of water treatment variables.

Leading edge microprocessor-based design, advanced surface mount component assembly techniques and a modular approach to hardware and software provide a wide choice of standard products.

Combined with an expanded selection of options, you can custom tailor these instruments to meet your exact requirements.

