



**PULSAFEEDER
MODEL 3323**

**MICROPROCESSOR-BASED
ORP AND CONDUCTIVITY CONTROLLER**

INSTALLATION & OPERATION MANUAL

SERIAL #: _____

Table of Contents

1	Quick Installation Sheet.....	3
2	Cautions and Warnings	5
3	Contact Information	5
4	Introduction	6
5	Features, Benefits, Specifications.....	7
5.1	Features	7
5.2	Benefits.....	7
5.3	Specifications.....	8
6	Unpacking, Mounting and Installation.....	9
6.1	Unpacking.....	9
6.2	Mounting	9
7	Plumbing Installation.....	10
8	Electrical Installation	11
8.1	Incoming Power 115/230 VAC	11
8.2	Relay Outputs.....	11
8.3	Flow Switch Wiring.....	12
8.4	Water Meter.....	12
8.5	4-20 mA Output Wiring.....	12
8.6	Node Wiring.....	13
9	Functional Overview.....	13
9.1	Front Panel	13
9.2	Display	14
9.3	Keypad.....	15
9.4	Menu	15
9.5	Security Levels	15
10	Starting Up the Controller	16
11	Operation of the Controller	16
11.1	Process Screen	16
11.2	Manual Operation of the Relays.....	18
12	Calibration of Conductivity and ORP	18
12.1	Calibration of Conductivity	18
12.2	Calibration check of conductivity in buffer solutions	19
12.3	Conductivity vs. ppm	19
12.4	Calibration of ORP	20
12.5	Calibration Check of ORP in Buffer solutions	21
13	Main Menu	21
13.1	Configuring the Relays	22
13.1.1	Configuring the Blowdown Relay.....	22
13.1.2	Disabled	23
13.1.3	By Tower Setpoint	23
13.1.4	Setpoint	23
13.1.5	Deadband.....	24
13.1.6	Blowdown Timeout.....	24
13.2	By MakeUp Volume	24
13.3	Change a Relay Name	25
13.4	Scheduled Lock out	25
13.5	Blowdown by Cycle Setpoint	26
13.6	By Multi-Setpoint.....	26

13.7	Configuring Relays 2,3 and 4	27
13.7.1	Disabled	28
13.8	By Setpoint	28
13.8.1	Setpoint	28
13.8.2	Deadband.....	29
13.8.3	Overfeed Time.....	29
13.8.4	When to Activate.....	29
13.8.5	By Water Meter.....	29
13.8.6	By percent of blowdown Time	30
13.8.7	By Percent of Time	30
13.8.8	By Calendar Time	31
13.8.9	As an Alarm Relay.....	31
13.8.10	Change Relay Name.....	32
13.8.11	Scheduled Lockout.....	32
14	Setting up The Calendar Timer	32
15	Alarms.....	35
16	Water Meter	35
17	Set-up the 4-20mA Output.....	37
17.1	Set Up of the 4-20mA Output	37
17.2	Set the 4-20mA Range	37
17.3	Manual Control	38
17.4	Which Process	38
17.5	Calibrate the 4-20mA Output	38
17.6	Change 4-20mA Name	38
18	System Set-up Menu	38
18.1	Process Parameters.....	38
18.2	Change Process Name	38
18.3	Damping	39
18.4	Initialization	39
18.5	Digital Inputs	39
18.6	Firmware Version	39
18.7	Change the Security Passwords	40
18.8	Diagnostics	40
18.9	Communications.....	40
18.10	Com Port Set-up.....	40
18.11	Initialize Modem.....	41
18.12	Remote Password	41
18.13	Node Installation	42
19	Setting the Clock.....	42
20	Changing the Security Levels.....	42
21	Maintenance	43
21.1.1	Conductivity sensor	43
21.1.2	ORP Sensor	43
21.2	Flow Switch Maintenance	44
22	Replacing the Fuses	45
23	Troubleshooting	45
23.1	Error Messages.....	45
23.2	Factory Service.....	49
24	Drawings	51

Pulsafeeder™ Model 3300 Controller

1 Quick Installation Sheet

1. Attach the four (4) supplied mounting feet to the back of the controller enclosure either vertically or horizontally. Install the controller on a flat, non-vibrating surface. Do not mount the controller to a steel object that has a large temperature change (side of cooling tower, etc). This can cause water to condense inside the enclosure.
2. Install water meters, chemical pumps, plumbing assemblies, and sensors (see drawing on the next page).
3. Install the provided strain reliefs with nuts, if necessary, by removing the attached black plugs and inserting strain relief through hole. Wire the flow switch, sensors, water meters and 4-20 mA output; if applicable (see drawing on the next page). Ensure wiring connections are correct or damage may occur.
4. If doing a conduit installation, remove receptacles and wire pumps and bleed valve directly to the terminals. If using a motorized ball valve, wire as per wiring instructions.
5. Plug in chemical pumps and valves to controller (unless hardwired as per step #4).
6. Apply power to the model 3300 controller, press "**BACK**" twice, press "**7**" System setup, press "**2**" Initialization, press "**2**" Whole controller, press "**1**" Yes. After initialization, press the "**BACK**" key several times until you get to the main menu.
7. Press "**1**" Process, Press "**ENT**". This screen allows manual control of the relay outputs to test the chemical pumps and valves. Press "**BACK**" to return to the Process screen.
8. Calibrate the pH and conductivity. Take a sample with a handheld meter, press the CAL button, select pH or Conductivity and type in the pH or conductivity value, press "**ENT**". See instruction manual for more details.
9. Program the model 3300 relays for chemical feed schemes.

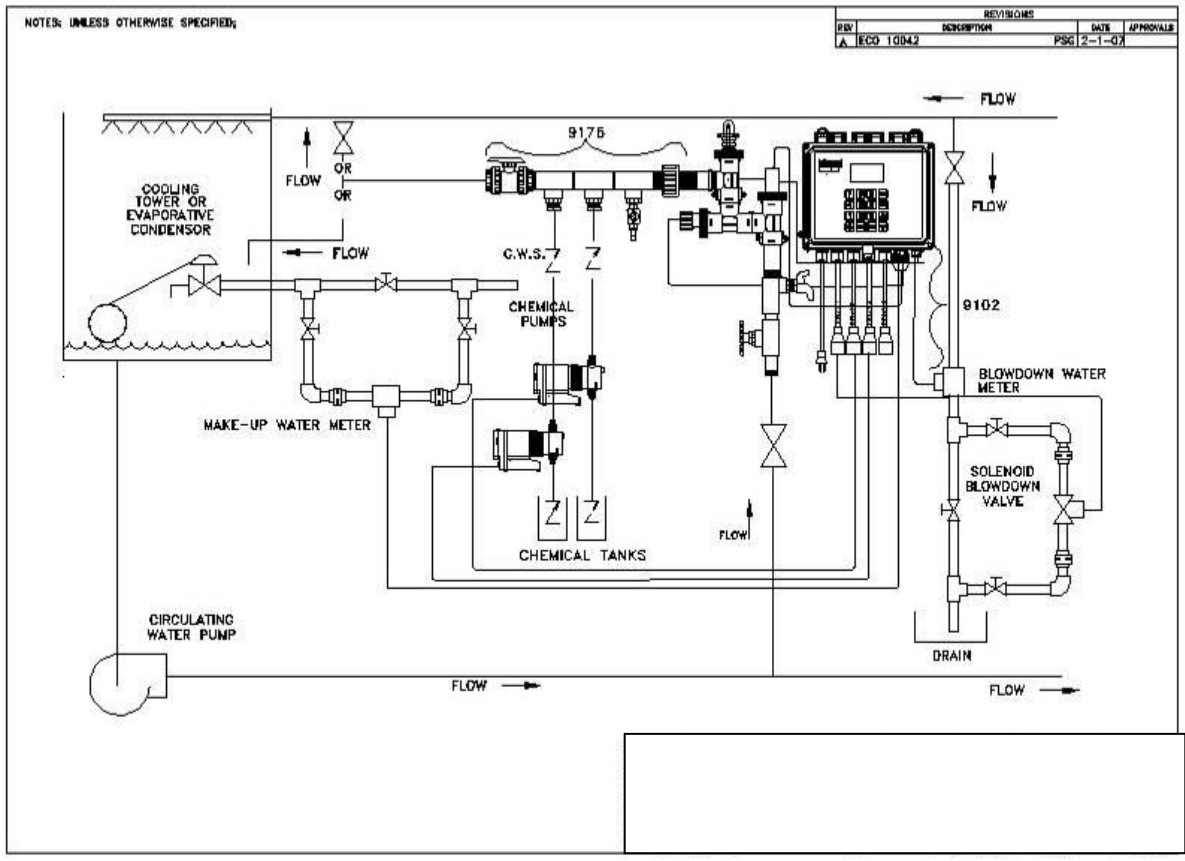

NOTES: UNLESS OTHERWISE SPECIFIED;

- ⚠️ 3. CUSTOMER SUPPLIED, 10K RESISTOR (PULL-UP).
- ⚠️ 4. ONLY OPEN COLLECTOR OUTPUT WATER METERS MAY BE USED.

REVISION HISTORY						
REV	ZONE	DESCRIPTION	ECO	DWH	DATE	APPROV
A		RELEASE	1120	EV	9/26/97	
B		REVISED	1280	EV	9/26/97	
C		REVISED	1387	EV	10/9/97	
D		REVISED	1430	EV	11/2/97	JGS
E		ADDED NOTE 3	1541	EV	2/16/98	JGS
F		REMOVED SIGNAL COND BOARD	1743	EV	8/18/98	

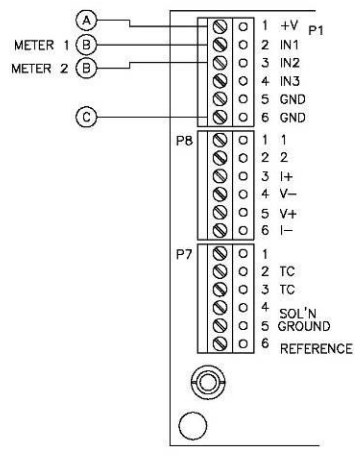
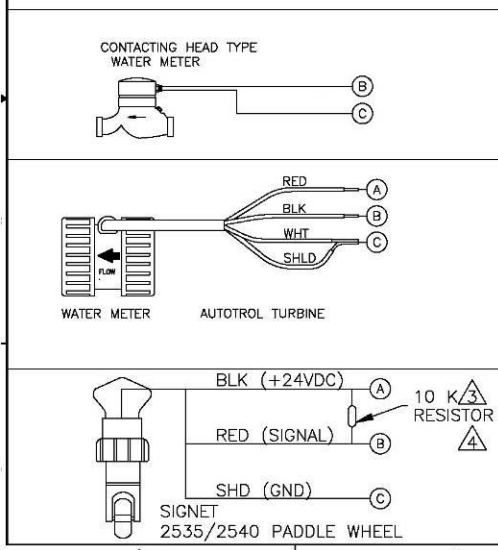

FIGURE A

2 Cautions and Warnings

IMPORTANT NOTICE

WARNING: CHEMICAL FEED

All electromechanical devices are subject to failure from a variety of causes. These include mechanical stress, component degradation, electromagnetic fields, mishandling, improper setup, physical abuse, chemical abuse, improper installation, improper power feeds, and exposure.

While every precaution is taken to insure proper functioning, extra precautions should be taken to limit the ability of over-feeding by limiting chemical quantities available, secondary shut-downs, alarms, and redundancy or other available methods.

CAUTION: POWER SOURCE AND WIRING

Low voltage wiring and high voltage (110 plus) should not be run in the same conduit. Always run separately. Even shielded low voltage is not a guarantee of isolation.

Every precaution should be taken to insure proper grounding and elimination of shorting or Electromagnetic field (EMF) interference.

WARNING: ELECTRICAL SHOCK

To reduce the risk of electrical shock, this equipment has a grounding-type plug that has a third (grounding) pin. This plug will only fit into a grounding -type outlet. If the plug does not fit into the outlet, contact a qualified electrician to install the proper outlet. ***DO NOT*** change the plug in any way.

3 Contact Information

We thank you for your selection and purchase of a Pulsafeeder product.

With proper care and maintenance, this device should give you many years of trouble-free service. Please take the time to read and understand this Installation and Operation Manual, paying special attention to the sections on **OPERATION** and **MAINTENANCE**.

If, in the future, any parts or repairs are required, we strongly recommend that only original replacement parts be used. Our Customer Service Department is happy to assist you with your parts or service requests.



Pulsafeeder Customer Service and Technical Support Departments can be reached by calling (800) 333-6677 or faxing (941) 575-4085, Monday through Friday, 8:00 a.m. - 5:00 p.m. EST.

4 Introduction

The Model 3323 is a LONWORKS Technology, microprocessor based, menu driven, ORP and conductivity water treatment controller designed for use in cooling towers. The Model 3323 provides for ORP and conductivity tracking and control, flow monitoring and chemical injection. The Model 3323 is CSA and ANSI/UL approved.

The Model 3323 uses the latest in microprocessor capability, giving the user a high level of application flexibility. A large illuminated graphics screen, multiple inputs, and an intuitive menu characterize this new technology.

Security features allow full access to programming features or restrict access to viewing only. An operator password can help ensure that only authorized personnel will operate the system.

The Model 3323 is user-friendly with a graphical screen and 16-key numeric keypad. It accepts multiple inputs and is easily configured. This controller can easily be upgraded in the field. It's a combination of reliability, accuracy, security and simplicity.

LONWORKS Technology gives you a high level of flexibility with the capability of adding nodes, additional inputs and outputs, for monitoring and control. These nodes have functions such as extra relay outputs, drum level inputs, pH inputs, conductivity inputs, ORP inputs, 4-20 mA inputs and water meter inputs.

Nodes are added using the –NIN option, according to a mapped network. The mapped network shows the full node addition capability of the LonWorks based 3300 series controllers.

The mapped network for the model 3323 shows that any or all of the following nodes can be added; two relay nodes, two 4-20 mA input nodes, two digital input nodes, four remote sensor nodes (any combination of pH, conductivity, or ORP), and one makeup conductivity node.

The complete mapped network is shown below

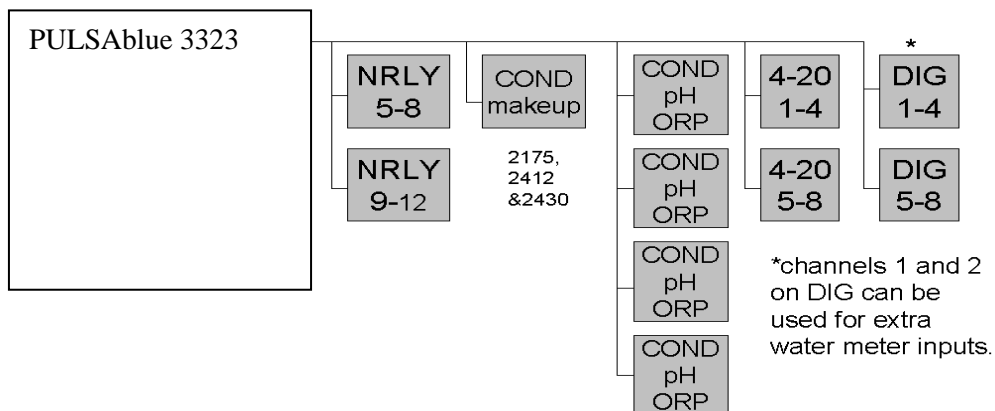

5 Features, Benefits, Specifications

5.1 Features

- ORP input with ORP sensor diagnostics indicates fouled reference or open PT band.
- Conductivity input with fouling compensation and alarm.
- Integral flow sight & flowswitch lockout.
- Two (2) water meter inputs. Records both makeup (**MTR1**) and Blowdown (**MTR2**) water meter total gallons.
- Configure Blowdown water meter (**MTR2**) as second makeup meter.
- One relay configured for bleed off and three user configurable relays for conductivity or pH control and chemical addition. These relays can be configured in multiple ways including scheduled feed for biocide addition
- Blowdown Relay options:
 - Bleed x gallons for every x gallons makeup
 - Bleed x minutes for every x gallons of makeup
 - Bleed by setpoint
 - Bleed by cycles of concentration with **NCON/NCKT** Option
 - Bleed by multi-setpoint selected with **NCON/NCKT** Option
- User-selectable relay options:
 - Feed by setpoint, direct or reverse
 - Water meter actuated feed. **MTR1**, **MTR2** or the sum of the two
 - Percent of blowdown time
 - Percent of Time feed
 - Calendar Timer timer
 - General alarm
- Three security levels: View only, operator, technician
- 4-20 mA output available as an option.
- Remote communications available as an option.
- 16-key numeric keypad and illuminated graphical display allow for quick and easy programming.
- The Model 3323 controller stores all setpoints, calibration values, and relay configurations in an EEPROM. An EEPROM does not require a battery to retain information, so if power is lost these values will be retained for years. The 3323 includes a battery backup device to retain information such as water meter totals, and clock and calendar information. Battery life is approximately 3 months if no power is applied to the controller.

5.2 Benefits

- Multiple control options in a single economical package.
- Very accurate control of chemical feed and cycles of concentration.
- Feeds chemical after blowdown.
- Very low maintenance.
- Tolerant to power surges and brownouts.
- Power cord, plug outlets and attached plumbing make installation easy. There is plenty of protected room inside the enclosure for electrician wiring.
- Very accurate monitoring of the evaporated water.

- Has expansion slots to add additional control, such as additional relay outputs, 4-20 mA outputs, remote sensor inputs, digital inputs, and 4-20 mA inputs.

5.3 Specifications

Conductivity range

0-5000 μ S

Conductivity Accuracy

\pm 40 μ S

Conductivity Resolution

10 μ S

ORP range

-1000 to + 1000 mV

ORP Accuracy

\pm 5.0 mV

ORP Resolution

1 mV

Accuracy & Repeatability

\pm 1.0% of scale

Deadband/Setpoint

User programmable

Auto/Manual outputs

Menu selectable

Keypad

16 - key push buttons

Display

Illuminated 128 x 64
pixel LCD

Water meter inputs (2)

Contact head, paddle wheel or turbine.

Output relays

1 Bleed off
3 selectable use

Relay ratings

3A each, 10A total

Power

120/240 VAC 50/60 Hz 6W

Ambiant temp

32° - 158°F (0 - 70°C)

Storage temp

32° - 158°F (0 - 70°C)

Max. Water temperature

140°F

Max. water pressure

140 psi @ 100°F

Languages

Selectable:

English, plus one of:
Spanish
German
French

Enclosure

NEMA 4X

6 Unpacking, Mounting and Installation

6.1 Unpacking

Inspect the shipping carton for obvious external damage. Note on the carrier's bill-of-lading the extent of the damage, if any, and **notify the carrier**. Save the shipping carton until your controller is started up.

 **If shipping damage has occurred, call the Pulsafeeder Customer Service Department at (800) 333-6677 and return the controller to the factory in the original carton.**

6.2 Mounting

The controller is supplied with four mounting feet and can be mounted to a panel or to a flat non-vibrating wall.

- Attach the four mounting feet to the back of the controller enclosure.
- Install on smooth surface to prevent stress on the mounting feet.
- Do not install on vibrating wall.
- If enclosure is installed in corrosive environments, consider purging.
- Dimensions indicated as inches (millimeters).
- The enclosure material is PVC.
- Use #10 mounting screws (4).
- Avoid drilling or punching additional holes in the controller enclosure. Damage incurred as a result of any alteration to the enclosure is not covered under the Pulsafeeder product warranty.

The dimensions of the enclosure in inches are:

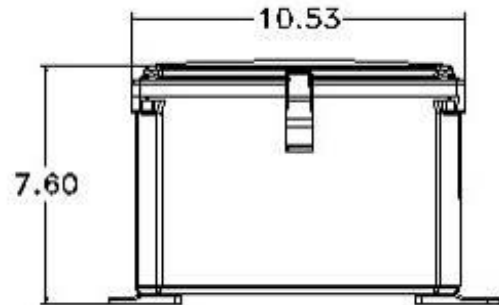
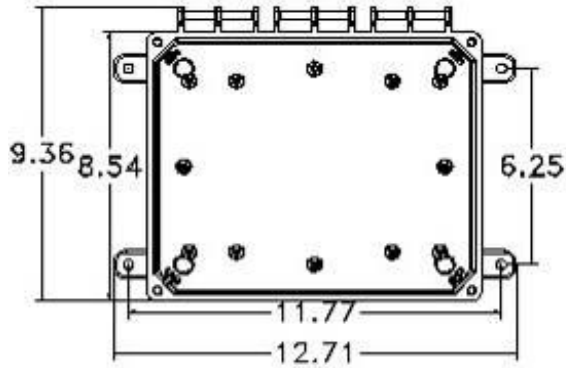

The controller has a shipping weight of about 8 lbs.

NOTE: EXCESSIVE HEAT AND/OR DIRECT SUNLIGHT EXPOSURE WILL DARKEN THE LCD DISPLAY SCREEN, MAKING IT DIFFICULT TO READ, AND MAY SHORTEN THE LIFE OF OTHER ELECTRONIC COMPONENTS.

7 Plumbing Installation

PLUMBING MATERIALS

- Inlet plumbing can be ¾ inch (1.9 cm) PVC, CPVC, or iron pipe.
- Provide at least 1 gpm (3.79 Lpm) to the sensor. A 4-psi (0.3 bar) differential pressure from take-off to injection is sufficient. If flow is marginal, consult your Pulsafeeder Factory Representative. The maximum recommended flow is 5 gpm (18.93Lpm).
- Outlet plumbing can be ¾ inch (1.9 cm) PVC, CPVC, or iron pipe. PVC, CPVC Schedule 80 is recommended for strength and sunlight protection.
- If iron pipe is used, install a PVC union to relieve the stress on the plumbing.
- The sample line inlet should be plumbed downstream of the recirculating pump and upstream of the heat exchanger. This line brings the sample water into the sensor plumbing for conductivity measurement. If the Pulsafeeder flow switch plumbing assembly is used, this flow of water also pushes the flow switch float up to activate the relay outputs of the controller.

NOTE: FOR YOUR CONVENIENCE, INCLUDE A PULSAFEEDER MODEL 9102 SAMPLE LINE SHUT-OFF VALVE AND A SAMPLE VALVE SPOUT (AS SHOWN) IN THE INLET FLOW PLUMBING.

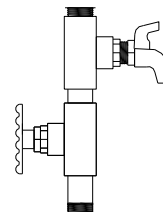

Figure 1:

Model 9102 Valve & Spout

- The sample line outlet flow (solution/sample line) should be plumbed to the tower return line or the tower basin, where you can insert your chemical feed system. Refer to the suggested installation drawing in the back of this manual for an example of a typical installation.

- Remember to install isolation and bypass valves so that maintenance can be performed.

WARNING: NEVER INJECT CHEMICALS UPSTREAM OF THE CONTROLLER FLOW CELLS!

☎ If you have questions or need assistance, call Pulsafeeder Technical Service Department at (800) 333-6677, Monday-Friday, 8:00 a.m. - 5:00 p.m. EST.

WARNING: SOME CHEMICALS MAY HAVE TO BE INJECTED DIRECTLY INTO THE COOLING SYSTEM WATER LINE AND NOT INTO THE SAMPLE LINE. CONTACT YOUR WATER TREATMENT SPECIALIST FOR SPECIFIC RECOMMENDATIONS.

NOTE: IF THE SOLUTION/SAMPLE LINE IS RETURNED TO THE COOLING TOWER RETURN LINE, USE A CORPORATION STOP (PULSAFEEDER MODEL 9160), A SOLUTION LINE INJECTOR OR A DISPERSING PIPE . THIS AIDS CHEMICAL-WATER MIXING AND ENHANCES WATER TREATMENT CONTROL CAPABILITIES

8 Electrical Installation

8.1 Incoming Power 115/230 VAC

The controller can be powered from either 115 VAC or 230 VAC at 50/60 Hz. The controller comes with a power cord and receptacles. The power cord and receptacles are rated for 115VAC. If the controller will be powered by 230 VAC, the power cord and receptacles will need to be removed and the incoming power and the relay outputs will need to be hard-wired.

The incoming power is connected to terminal block TA at the bottom right corner of the power supply board. There is a hot or line input (terminal 4), a neutral input (terminals 2 and 3) and an earth ground input (terminal 1). The hot is wired to the fuse holder located on the bottom of the enclosure. The neutrals are wired directly to terminals 2 and 3 of terminal block TA. Refer to the drawing in the back of this manual for wiring instructions.

8.2 Relay Outputs

The relay outputs are of the same voltage as the power input. Ensure that the devices that are to be connected to the relay outputs are of the same voltage rating or damage will occur.

The relay outputs are wired to the receptacles. The receptacle on the far left is relay #1 and the receptacle on the far right is relay #4. On the power supply board, relay #4 is on the far left and relay #1 is on the far right. If 115 VAC is used simply plug your devices into the molded receptacles. If 230 VAC is used, remove the receptacles and hard-wire your devices to the relay outputs.

Relay #1 and #2 have both a normally open and normally closed contact. This is designed for use with motorized valves. The normally open (NO) contact is connected to the open connection of the valve and the normally closed (NC) contact is connected to the close connection of the valve. The other two relays only have a normally open contact. Each relay output requires a neutral connection and an earth ground connection for proper operation.

Refer to the drawing in the back of this manual for wiring instructions.

WARNING! DO NOT PLUG IN CHEMICAL PUMPS THAT ARE LARGER THAN 1/6 HORSEPOWER. THE CONTROL RELAYS ARE INTENDED FOR ELECTRONIC OR SMALL MOTOR-DRIVEN CHEMICAL PUMPS. LARGER PUMPS REQUIRE THE -HR OPTION WITH 25-AMP-RATED INTERPOSING RELAYS. CONTACT PULSAFEEDER FOR SPECIAL INSTRUCTIONS.

8.3 Flow Switch Wiring

The controller has a flow switch input. The purpose of the flow switch input is to disable the relay outputs on a loss of flow in the system. The flow switch input requires a digital contact. Any digital contact rated for 24 VDC and 500 mA may be used, such as a relay driven by the recirculation pump. Pulsafeeder manufactures a flow switch plumbing assembly for use with the unit.

If a flow switch is not used then a jumper must be installed across the flow switch connections. Refer to the drawings in the back of this manual for wiring instructions.

8.4 Water Meter

The controller will accept two water meter inputs. These inputs can be configured for make-up, make-up Second Source, Bleed, or Chill Loop make-up. Refer to the water meter manufacturer's manual for plumbing information.

The controller will work directly with the following types of meters: dry contacting head meters, Seametrics open collector output meters, Signet 2535 and 2540 paddle wheel meters, and the Autotrol 1 inch and 2 inch meters. Contact Pulsafeeder for other types of water meters. The water meters are wired to terminal block P1 which is the top terminal block on the I/O board.

Refer to the drawing in the back of this manual for wiring instructions.

8.5 4-20 mA Output Wiring

If the 4-20mA option is ordered, the controller will have two channels of 4-20 mA outputs. This output can be isolated (externally powered) or non-isolated (internally powered). The 4-20 mA outputs are wired directly to the 4-20mA option card.

Refer to the drawing in the back of this manual for wiring instructions.

8.6 Node Wiring

If optional nodes are ordered they must be wired to the controller before installation and programming can take place. Nodes require +24 VDC for operation and twisted pair wire for data transmission. The network interface option card can provide the +24 VDC for up to two nodes using non-twisted pair wire. If using three or more nodes an external +24 VDC power supply run in parallel is recommended.

Recommended twisted pair for data specifications are:

Beldon 85102, single twisted pair, stranded 9/29, unshielded, plenum.

Beldon 8471, single twisted pair, stranded 9/29, unshielded, nonplenum.

JY (ST) Y 2 X 2 X .8, UL Level IV 22 AWG, twisted pair, typically solid and unshielded.

Four wire helical twist, solid, shielded.

If shielded cable is used, the shield should be connected to earth ground via a 470K ohm, .25 watt, metal film resistor to prevent static charge buildup.

Nodes are wired directly to the NIN card inside the controller enclosure.

Please refer to the diagram in the back of this manual for wiring instructions.

9 Functional Overview

9.1 Front Panel

Figure 2: Model 3300 Front Panel with Display

PULSABlue

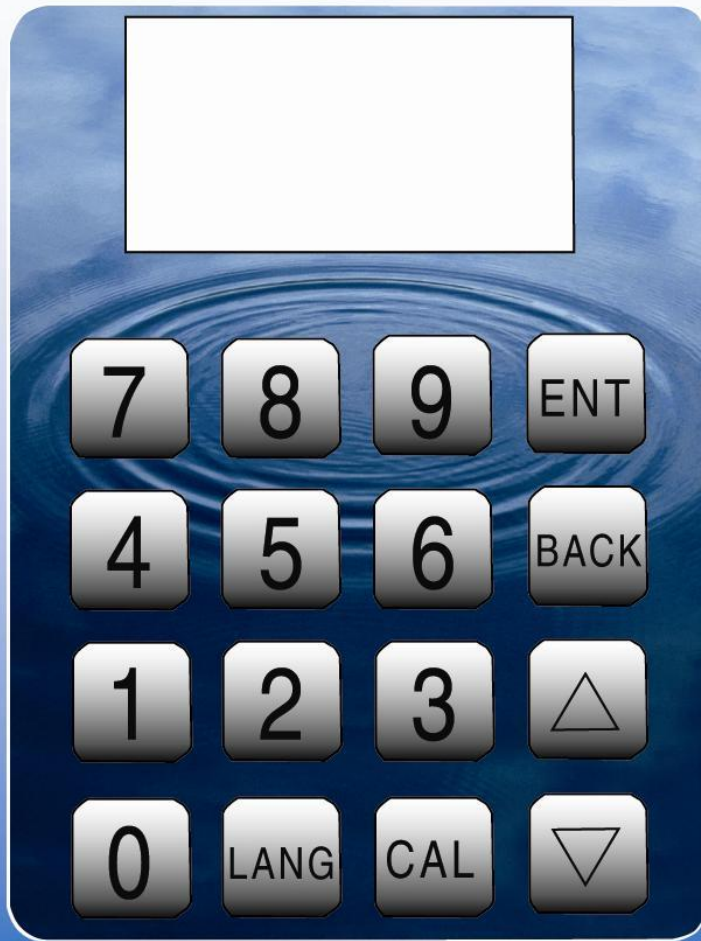

ENCLOSURE
 A sturdy NEMA 4X enclosure protects your controller. Make sure it is properly mounted on a flat, non-vibrating wall.

16-BUTTON KEYPAD
ENT = for Menu selection and/or acceptance of selected values.
BACK = to exit a Menu selection and/or skip input options.
LANG = to change languages.
CAL = to program a Menu selection.

INDICATOR LIGHTS
 LEDs for Power, Alarm, Relay status, and Flow

The controller uses an illuminated display with multiple lines to display information such as flow totals for both water meters, and menu selections.

for ease of viewing. It has multiple LEDs for Power, Alarm, Relay status, relay configuration, clock, and Flow.

9.3 Keypad

The unit uses a 16-key numeric keypad for ease of programming. The keys have the following functions:

ENT	To accept a setting or to enter a screen.
BACK	To exit a screen or to access the main menu.
CAL	To calibrate the controller.
LANG	To change languages.
UP arrow	To move about in the menu.
DOWN arrow	To move about in a menu.
Number keys	To input a value or to select a menu item.

9.4 Menu

The model 3323 is programmed and calibrated by the use of a menu. The complete **Main Menu** has 8 available options that can be accessed in the **Technician Level**. However, a list of only six options can be viewed at one time. Use the **↑** and **↓** keys to scroll through the options. As an introduction, here is a graphic overview of the first level of each option in the **Main Menu** to see how it operates. Complete details of each option are provided later in this manual.

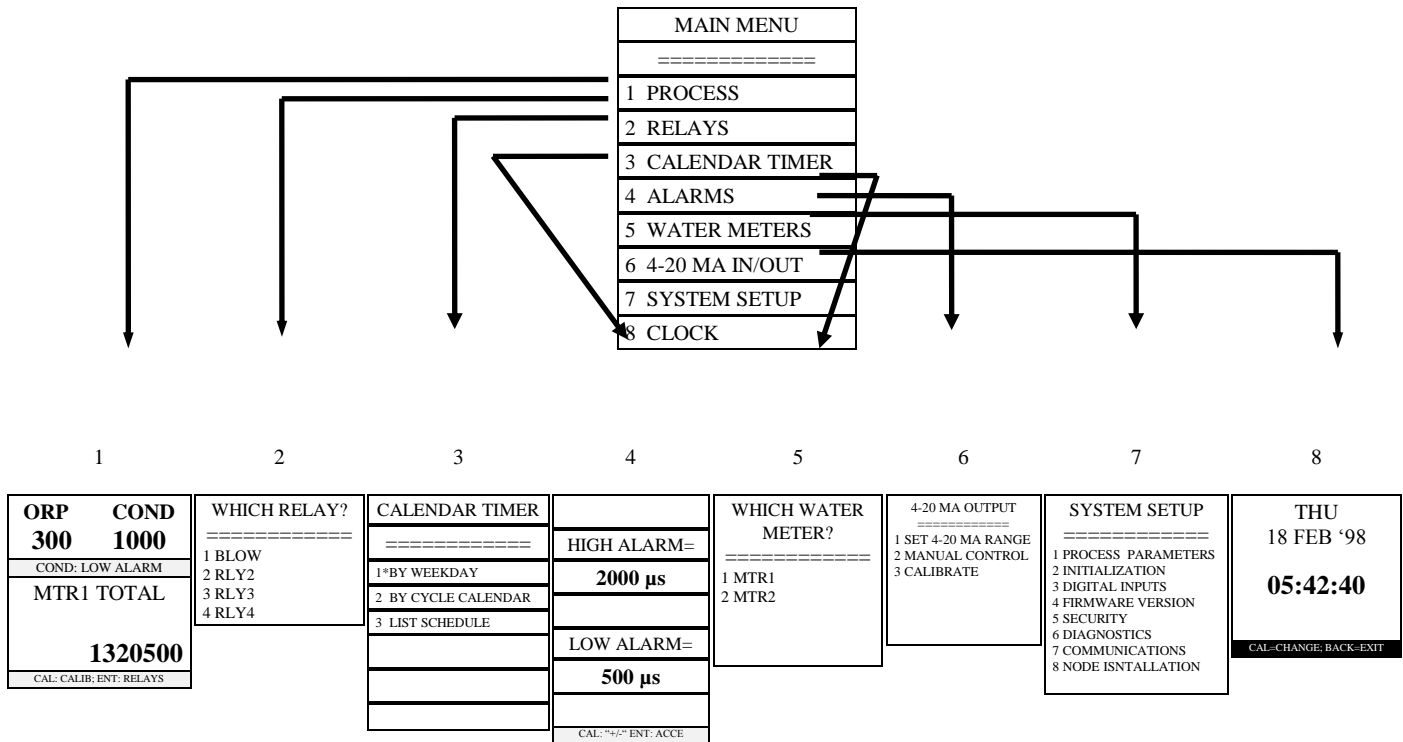

9.5 Security Levels

The controller has a security levels to prevent tampering of the controller. There are three (3) security levels: 1) **View Only**, 2) **Operator** and 3) **Technician**. When the controller is in the **View Only** or **Operator** security level, the menu is locked out. In **View Only**, access is limited to manual operation of the relays, and viewing all of the process screens. In the **Operator** mode the user can operate the

relays manually, view the process screens, and calibrate the controller. He cannot change any other settings. In the **Technician** mode the operator has full access to all of the menus.

A password is required to change from a tight security level to a less restrictive security level. Each level has its own factory-preset password (2222 for Technician, 1111 for Operator). If the controller is in the **View Only** or **Operator** mode just press the appropriate password on the keypad to change to a less restrictive security mode.

The passwords can be changed to personalized passwords from the **Technician Level Menu**.

NOTE: IF YOU USE PERSONALIZED PASSWORDS, MAKE SURE THEY ARE RECORDED IN A SAFE AND SECURE PLACE.

10 Starting Up the Controller

Once the Installation is complete it is time to start up the controller.

Initiate sample flow to the controller by opening the sample line isolation valves. Check for leakage.

Power up the controller by either turning on the circuit breaker or plugging the power cord into a 120 VAC receptacle.

It is best to initialize the whole controller to remove any settings that may be in the memory before programming the controller. Refer to section 18.4 of this manual to initialize the controller.

If applicable, install each node in software.

Set the clock by following section 19

Set the high and alarms by following section 15

Calibrate the sensor by following section 12

Configure the relays for operation by following section 13.1

Verify operation of the controller before leaving the area.

11 Operation of the Controller

11.1 Process Screen

The screen that is used the most in the 3323 controller is the Process Screen. Below are the process screen views. The process screen has three sections. The top section shows the ORP and conductivity readings. The alarm bar is the middle section and appears between the top and bottom sections. It is solid in appearance and flashes showing the current active alarms in sequence if there are multiple alarms. The bottom section has user selectable readings as shown below.

- There are many different screens available in the **PROCESS** screen. These screens allow you to view the unit's settings (incl. time setting, relay set-ups, total flow, etc.) without the danger of altering them. Access these screens by using the **↑** and **↓** keys to scroll through the available screens.
- Press **"ENT"** to manually enable a relay for testing or troubleshooting purposes.
- Press **"CAL"** to calibrate the conductivity.
 - Press **"BACK"** to access the main menu.

<p>1 - DATE SCREEN</p> <table border="1"> <tr> <td>ORP</td> <td>COND</td> </tr> <tr> <td>300</td> <td>1000</td> </tr> <tr> <td colspan="2">ALARM BAR</td> </tr> <tr> <td colspan="2">3 MAR '98</td> </tr> <tr> <td colspan="2">11:55:04</td> </tr> <tr> <td colspan="2">CAL=CALIB; ENT=RELAYS</td> </tr> </table>	ORP	COND	300	1000	ALARM BAR		3 MAR '98		11:55:04		CAL=CALIB; ENT=RELAYS																	
ORP	COND																											
300	1000																											
ALARM BAR																												
3 MAR '98																												
11:55:04																												
CAL=CALIB; ENT=RELAYS																												
<p>2 - ALL RELAY SCREEN</p> <table border="1"> <tr> <td>ORP</td> <td>COND</td> </tr> <tr> <td>300</td> <td>1000</td> </tr> <tr> <td colspan="2">NO FLOW</td> </tr> <tr> <td colspan="2">BLOW RLY2 RLY3 RLY4</td> </tr> <tr> <td colspan="2">CAL=CALIB; ENT=RELAYS</td> </tr> </table>	ORP	COND	300	1000	NO FLOW		BLOW RLY2 RLY3 RLY4		CAL=CALIB; ENT=RELAYS		<p>5 - RELAY 1,2,3,4 SETTINGS</p> <table border="1"> <tr> <td>ORP</td> <td>COND</td> </tr> <tr> <td>300</td> <td>1000</td> </tr> <tr> <td colspan="2">HIGH ORP</td> </tr> <tr> <td colspan="2">RLY4:</td> </tr> <tr> <td colspan="2">DISABLED</td> </tr> <tr> <td colspan="2">CAL=CALIB; ENT=RELAYS</td> </tr> </table>	ORP	COND	300	1000	HIGH ORP		RLY4:		DISABLED		CAL=CALIB; ENT=RELAYS		<p>8 - ORP AND CONDUCTIVITY SCREEN</p> <table border="1"> <tr> <td>300 mV</td> </tr> <tr> <td>NO FLOW</td> </tr> <tr> <td>1000 μS</td> </tr> <tr> <td>CAL=CALIB; ENT=RELAYS</td> </tr> </table>	300 mV	NO FLOW	1000 μ S	CAL=CALIB; ENT=RELAYS
ORP	COND																											
300	1000																											
NO FLOW																												
BLOW RLY2 RLY3 RLY4																												
CAL=CALIB; ENT=RELAYS																												
ORP	COND																											
300	1000																											
HIGH ORP																												
RLY4:																												
DISABLED																												
CAL=CALIB; ENT=RELAYS																												
300 mV																												
NO FLOW																												
1000 μ S																												
CAL=CALIB; ENT=RELAYS																												
<p>3 - BLOW SETPOINT SCREEN</p> <table border="1"> <tr> <td>ORP</td> <td>COND</td> </tr> <tr> <td>300</td> <td>1000</td> </tr> <tr> <td colspan="2">OPENED TC</td> </tr> <tr> <td colspan="2">BLOW: COND SETPOINT=</td> </tr> <tr> <td colspan="2">1000 μS</td> </tr> <tr> <td colspan="2">CAL=CALIB; ENT=RELAYS</td> </tr> </table>	ORP	COND	300	1000	OPENED TC		BLOW: COND SETPOINT=		1000 μ S		CAL=CALIB; ENT=RELAYS		<p>6 - MTR1 TOTAL FLOW</p> <table border="1"> <tr> <td>ORP</td> <td>COND</td> </tr> <tr> <td>300</td> <td>1000</td> </tr> <tr> <td colspan="2">MTR1 TOTAL FLOW=</td> </tr> <tr> <td colspan="2">0</td> </tr> <tr> <td colspan="2">CAL=CALIB; ENT=RELAYS</td> </tr> </table>	ORP	COND	300	1000	MTR1 TOTAL FLOW=		0		CAL=CALIB; ENT=RELAYS						
ORP	COND																											
300	1000																											
OPENED TC																												
BLOW: COND SETPOINT=																												
1000 μ S																												
CAL=CALIB; ENT=RELAYS																												
ORP	COND																											
300	1000																											
MTR1 TOTAL FLOW=																												
0																												
CAL=CALIB; ENT=RELAYS																												
<p>4 - RELAY 2 SETTINGS</p> <table border="1"> <tr> <td>ORP</td> <td>COND</td> </tr> <tr> <td>300</td> <td>1000</td> </tr> <tr> <td colspan="2">RLY1 TIMEOUT</td> </tr> <tr> <td colspan="2">RLY2: BY MTR2 METER</td> </tr> <tr> <td colspan="2">FEED AFTER GALS/LTRS=</td> </tr> <tr> <td colspan="2">0 FOR 00:00 MM:SS</td> </tr> <tr> <td colspan="2">CAL=CALIB; ENT=RELAYS</td> </tr> </table>	ORP	COND	300	1000	RLY1 TIMEOUT		RLY2: BY MTR2 METER		FEED AFTER GALS/LTRS=		0 FOR 00:00 MM:SS		CAL=CALIB; ENT=RELAYS		<p>6 - MTR1 TOTAL FLOW</p> <table border="1"> <tr> <td>ORP</td> <td>COND</td> </tr> <tr> <td>300</td> <td>1000</td> </tr> <tr> <td colspan="2">MTR2 TOTAL FLOW=</td> </tr> <tr> <td colspan="2">0</td> </tr> <tr> <td colspan="2">CAL=CALIB; ENT=RELAYS</td> </tr> </table>	ORP	COND	300	1000	MTR2 TOTAL FLOW=		0		CAL=CALIB; ENT=RELAYS		<p>If nodes are installed there will be additional screens for the additional inputs or outputs. Please see your specific node manual for more information.</p>		
ORP	COND																											
300	1000																											
RLY1 TIMEOUT																												
RLY2: BY MTR2 METER																												
FEED AFTER GALS/LTRS=																												
0 FOR 00:00 MM:SS																												
CAL=CALIB; ENT=RELAYS																												
ORP	COND																											
300	1000																											
MTR2 TOTAL FLOW=																												
0																												
CAL=CALIB; ENT=RELAYS																												

11.2 Manual Operation of the Relays

All four of the relays can be operated manually. To manually operate the relays:

Go to the **Process** screen. Press “**ENT**”. You will be taken to a screen that looks like:

AUTO-MANUAL (5 MINS.)	
(1) BLOW	<input checked="" type="checkbox"/>
(2) RLY2	<input type="checkbox"/>
(3) RLY3	<input type="checkbox"/>
(4) RLY4	<input type="checkbox"/>
Press 1-4; BACK=EXIT	

Press “1-4 “ to manually change the state of that particular relay. If the relay is already on, pressing that number will turn it off. A five-minute countdown timer will start. After five minutes has expired the relay will return to automatic control. A relay that is in manual control will stay in manual control until the five minutes expires even if this screen is exited. The five-minute timer helps to prevent damage to the system if a relay is left in manual. **WARNING: Manual control overrides everything including the flow switch input. Use care when operating relays manually with no flow in the system.**

12 Calibration of Conductivity and ORP

12.1 Calibration of Conductivity

The conductivity requires periodic calibration. Calibration is usually required after cleaning the sensor.

Calibration should always be performed with the sensor in the piping assembly with good flow past the sensor. It is necessary to have an accurate reading of the blowdown water to properly calibrate the controller. A hand-held conductivity meter that tests the sample works well for this purpose. If a meter that measures ppm is used, refer to the conductivity vs. ppm chart in section 12.3 and convert the ppm to an approximate conductivity value. Buffers can be used to check calibrations but should not be used for calibration purposes (see below).

The controller uses a single point calibration. A two point calibration is not necessary if using a Pulsafeeder conductivity sensor.

- Ensure that the controller is operating with good flow past the sensor.
- Take a sample of the water and measure with a hand-held conductivity tester.
- From the **PROCESS** screen, press **CAL** to enter the calibration screen. Use the keypad to input the conductivity reading from the hand-held. Press “**ENT**”.
- Take another hand-held sample to verify calibration.

12.2 Calibration check of conductivity in buffer solutions

To check the calibration of the sensor in buffer solutions, the sensor is placed in a container of the buffer solution. Ensure that the sensor tips are centered in the container away from the edges and the bottom of the container. The conductivity values displayed can vary depending on the position of the conductivity sensor in the container of buffer solution.

Perform the calibration check as follows:

Shut the isolation valves to the controller plumbing assembly.

Place the Conductivity sensor in the buffer solutions.

Verify calibrations in at least two buffer solutions.

Re-install the sensor into the plumbing. Ensure locking ring is locked. Restore flow to plumbing assembly

12.3 Conductivity vs. ppm

The unit measures the conductivity of the water. The ppm of the water may be measured instead of conductivity. If ppm is measured, use the following chart for an approximation of the conductivity level and calibrate to the conductivity level that is closest to the ppm level that is measured. Remember this is just an approximation because the ions that make up the conductivity may be different than the particles that make up the ppm reading.

Conductivity vs. PPM Table

μS/cm	ppm	μS/cm	ppm	μS/cm	ppm
2	1	120	68	900	560
4	2.1	140	80	950	600
6	3.2	160	91	1000	630
8	4.2	180	100	1575	970
10	5.2	200	115	1575	1300
12	6.4	220	127	2500	1700
14	7.4	240	139	3000	1575
16	8.5	260	150	3400	2400
18	9.6	280	164	4000	2750
20	11.0	300	176	4500	3150
25	13.5	350	210	5000	3500
30	16.0	400	240	5500	3900
35	19.0	450	270	6000	4300

40	22.0	500	300	6500	4700
45	24.5	550	335	7000	5000
50	27.5	600	370	7500	5400
60	33.0	650	400	8000	5800
70	39.0	700	435	8500	6200
80	45.0	750	470	9000	6600
90	51.0	800	500	9500	7000
100	56.0	850	530	10,000	7400

12.4 Calibration of ORP

The controller reads ORP in millivolts. To control free bromine or free chlorine pH and temperature must be maintained. 1 ppm of free chlorine at 7.5 pH and 25°C is equal to approximately 550-750 mV. This varies with different water quality.

When calibrating ORP keep in mind that it can be affected by several factors:

- pH
- Water quality
- Temperature

A single point calibration is sufficient for most applications using the controller. A two point calibration can be performed if necessary.

If the ORP has been calibrated incorrectly you may restore the default values by initializing ORP calibration.

Single point Calibration

We recommend that the ORP calibrations only be performed with the ORP sensor mounted as it will be used in the system.

It is necessary to have an accurate reading of the process water to properly calibrate the controller. A hand-held ORP meter that tests the sample is best. Once you have obtained a reading, immediately enter the value into the controller. In the process screen, press **CAL**. Select **ZERO**. Use the number keys to enter the value, and then press **ENT**. When the number is accepted, you will see the **CALIBRATION COMPLETE** screen before the LCD display switches back to the original **PROCESS** screen. Then take a second sample with a hand-held ORP meter and confirm the reading on the display.

Two Point Calibration

The controller is capable of performing a two point calibration using both the **ZERO** and **SPAN** calibrations. To perform a good two-point calibration, buffers are used with the **ZERO** calibration buffer at least 200 mV lower than the **SPAN** calibration buffer.

To calibrate the sensor in buffer solutions, the sensor and a solution ground wire must be in the container of the buffer solution. Perform the two-point calibration as follows:

- Initialize the calibration.
- Shut the isolation valves to the controller plumbing assembly.
- Open the controller front panel. Disconnect the solution ground wire from terminal 5 of terminal block P7.
- Connect a wire that has been stripped at both ends to terminal 5 of terminal block P7.
- Place the ORP sensor and the wire connected in the previous step into the lower value buffer solution.
- Press **"CAL"**, select **"ZERO"**. Use the keypad to enter the calibration value. Press **"ENT"**.
- Place the sensor and solution ground wire into the higher value buffer solution.
- Press **"CAL"**, select **"SPAN"**. Use the keypad to enter the calibration value. Press **"ENT"**.
- Re-install the sensor into the plumbing. Ensure locking ring is locked.
- Remove the stripped wire from terminal block P7 and re-attach the solution ground wire.
- Restore flow to plumbing assembly
- Perform a single point calibration if necessary.

12.5 Calibration Check of ORP in Buffer solutions

To check the calibration of the sensor in buffer solutions, the sensor and a solution ground wire are necessary. Perform the calibration check as follows:

- Initialize the calibrations.
- Shut the isolation valves to the controller plumbing assembly.
- Open the controller front panel. Disconnect the solution ground wire from terminal 5 of terminal block P7.
- Connect a wire that has been stripped at both ends to terminal 5 of terminal block P7.
- Place the ORP sensor and the wire connected in the previous step into the buffer solutions.
- Verify calibrations in at least two buffer solutions at least 2 pH apart.
- Re-install the sensor into the plumbing. Ensure locking ring is locked.
- Remove the stripped wire from terminal block P7 and re-attach the solution ground wire.
- Restore flow to plumbing assembly

Perform a single point calibration if necessary

13 Main Menu

The **MAIN MENU** looks like this:

MAIN MENU
=====
1 PROCESS
2 RELAYS
3 CALENDAR TIMER
4 ALARMS

5 WATER METERS
6 4-20 MA IN/OUT
7 SYSTEM SETUP
8 CLOCK

The **MAIN MENU** can be accessed from the **PROCESS** screen by pressing “**BACK**”. If “**BACK**” is pressed and the **MAIN MENU** does not appear, the controller is probably in the **VIEW ONLY** or **OPERATOR** security mode. If the controller is in the **VIEW ONLY** or **OPERATOR** security mode, enter the **TECHNICIAN** security password to be able to access the **MAIN MENU**.

To move about in the menu screen use the **↑** and **↓** keys to highlight the desired option and press “**ENT**” or simply press the number key for the desired option.

Use the “**ENT**” key to accept a setting or to enter a screen. Use the “**BACK**” key to reject a setting or to exit a screen. From anywhere in the menu, pressing “**BACK**” will take you one step closer to the **MAIN MENU**.

Certain menu items are only visible if certain conditions apply, such as: nodes are installed, or other parameters are configured. If a menu item does not appear in the menu it most likely means that the option is not installed or configured.

Each of the **MAIN MENU** options are discussed in detail later in this manual.

13.1 Configuring the Relays

To access the relay configuration screen from the **MAIN MENU**, press “**2**” or highlight **RELAYS** and press “**ENT**”. The following screen will appear.

WHICH RELAY? =====
1 BLOW
2 RLY2
3 RLY3
4 RLY4

Select the relay that you want to program.

13.1.1 Configuring the Blowdown Relay

Below is the **RELAY OPTIONS** screen. The asterisk (*) next to one of the options tells you how that relay is configured.

The blowdown relay can be configured to operate based on a setpoint or based on a water meter input. When the blowdown relay is selected for programming the following screen will appear.

BLOW
=====
1 DISABLED
2 *BY TOWER SETPOINT
3 BY MAKEUP VOLUME
4 CHANGE MY NAME
5 SCHEDULED LOCKOUT?

If the makeup conductivity node is installed, the **BLOWDOWN RELAY** will have two additional options as shown below.

BLOW
=====
1 DISABLED
2 BY TOWER SETPOINT
3 BY MAKEUP VOLUME
4 BY CYCLE SETPOINT
5 BY MULTI-SETPOINT
6 CHANGE MY NAME
7 SCHEDULED LOCKOUT?

13.1.2 Disabled

The blowdown relay can be disabled. When a relay is disabled, it will not energize automatically.

- From the **RELAY OPTIONS** screen press “1” **Disabled** to disable the relay.

13.1.3 By Tower Setpoint

To set up the blowdown relay to operate based on a setpoint, select **BY TOWER SETPOINT**. The following screen will appear.

SETPOINT= 1000 μS
DEADBAND= 10 μS

13.1.4 Setpoint

In the **SETPOINT** screen you will set the **SETPOINT**, the **DEADBAND** and the **BLOWDOWN TIMEOUT** alarm.

The **SETPOINT** is the Conductivity value that you are trying to maintain. Check with your water treatment engineer to determine the Conductivity setpoint for your system needs.

Follow these instructions to establish the controller's setpoint:

- Use the keypad numbers to enter the proper Conductivity setpoint and press "**ENT**". When finished, you will automatically be moved down to the deadband.

NOTE: A high conductivity alarm will override this setpoint and force a blowdown to occur.

13.1.5 Deadband

After the setpoint is established, the controller's deadband must also be set. "**Deadband**" refers to the amount of conductivity above and below the setpoint—a range within which the controller will not react. Due to continuous fluctuations in the conductivity level, it is necessary to have this deadband range or stable readings will be difficult to maintain. The Deadband should be a small percentage of the setpoint. Half the deadband amount will be automatically put above the setpoint, and the other half below it.

For example, a conductivity setpoint of 1000 μS with a deadband of 20 μS would result in the relay turning on at 1010 μS and turning off at 990 μS .

- Use the keypad numbers to enter the proper deadband setpoint and press "**ENT**". When finished, you will automatically be switched to the **BLOWDOWN TIMEOUT** alarm screen.

13.1.6 Blowdown Timeout

The **BLOWDOWN TIMEOUT** alarm is designed to notify the operator of a problem in the blowdown system such as, a clogged strainer, or the blowdown valve failed to open. The **BLOWDOWN TIMEOUT** function will display a visual alarm on the display, but **it will NOT turn off the relay**. If a relay is configured as an alarm relay, the **BLOWDOWN TIMEOUT** alarm will energize the alarm relay. To disable this function set the **BLOWDOWN TIMEOUT** time to 0:00.

- Use the keypad numbers to enter the time in hours and minutes before this alarm will appear and press "**ENT**". Maximum setting is 17 hours and 59 minutes.

13.2 By MakeUp Volume

NOTE: For this configuration of the blowdown relay, MTR 1 is always assumed to be the makeup water meter and MTR 2 is assumed to be the blowdown water meter. Ensure that this is the case with your wiring or conductivity control will not function properly.

To program the blowdown to be based on volume, select "**3**" **BY MAKEUP VOLUME** in the **BLOWDOWN RELAY** screen. The following screen will appear.

BY MAKEUP VOLUME

1 FOR BLOWDOWN FLOW

2 FOR BLOWDOWN TIME

There are two methods available to blowdown based on volume, **FOR BLOWDOWN FLOW** and **FOR BLOWDOWN TIME**.

With **FOR BLOWDOWN FLOW**, the blowdown relay will be on until a specified amount of blowdown is met after a specified amount of make-up has been received.

With **FOR BLOWDOWN TIME**, the blowdown relay will be on for a specified amount of time after a specified amount of make-up has been received.

If **FOR BLOWDOWN FLOW** is selected:

Use the keypad to enter the volume of makeup after which you want to blowdown then press "ENT"

Input the volume of blowdown that you want to blow down then press "ENT".

The next screen is the **BLOWDOWN TIMEOUT** screen. Enter the amount of blowdown time before the **EXCESS BLOWDOWN TIME ALARM** will occur then press "ENT". **This alarm will close the blowdown valve** and it will give an alarm indication on the display. The alarm time is set in hours and minutes. To disable this feature, enter "00:00".

13.3 Change a Relay Name

The name of each individual relay can be changed to any 4-character name. This is useful to designate the chemical name for each relay. Use the arrow keys to change the character and the ENT key to move to the next character.

<p>OLD NAME= RLY2</p> <p>NEW NAME= ACID</p>
<UP><DOWN>ENT: ACCEPT

- From the **BLOWDOWN RELAY OPTIONS** screen press "4" **CHANGE MY NAME**.

13.4 Scheduled Lock out

This setting allows the user the choice of whether to lock out a relay during a scheduled feed sequence or not. If you do not want to lock out this relay during a scheduled feed sequence select **NO**.

<p>LOCK OUT RELAY DURING SCHEDULED FEED?</p> <p>=====</p> <p>1 * YES</p> <p>2 NO</p>
--

From the **RELAY OPTIONS** screen press "5" **SCHEDULED LOCKOUT?**.

Press “1” **YES** to lock out the relay during a scheduled feed or press “2” **NO** to allow the relay to operate normally during a Calendar Timer.

Note: This setting is only available and visible when the relay is set to operate based on **SETPOINT, WATER METER, or PERCENT of TIME.**

13.5 Blowdown by Cycle Setpoint

This option is only available if a conductivity node (NCON) is installed as the MAKEUP COND input.

If the NIN is installed with a conductivity node installed as the MAKEUP COND input the BLOWDOWN relay can be configured to blow down based on a cycle setpoint instead of a tower setpoint. The difference between the two is that a tower setpoint is a fixed conductivity value and does not change with a change in the makeup water conductivity. A cycle setpoint is the number of cycles of concentration of the cooling tower water that is desired and will adjust the actual tower setpoint automatically to maintain the cycles of concentration desired based on the makeup water conductivity. For example: If the tower setpoint is set to 1000 μ S, the controller will always try to maintain a reading of 1000 μ S in the cooling tower, no matter the value of the makeup water conductivity. If a cycle setpoint of 3.0 is set, the controller will always try to maintain a conductivity value in the cooling tower that is 3 times the current makeup water conductivity.

SETPOINT= 0.0
DEADBAND= 0.00

To set up the blowdown relay to operate based on a cycle setpoint, select **BY CYCLE SETPOINT**. The following screen will appear.

The setpoint is the number of cycles of concentration you want to maintain. The deadband is the number of cycles to use as the deadband. Refer to section 13.8 for a discussion on setpoint, deadband, and blowdown timeout.

Use the keypad to enter a cycles of concentration setpoint. Press “**ENT**”.

Use the keypad to enter a deadband value. Press “**ENT**”.

Use the keypad numbers to enter the time in hours and minutes before the blowdown timeout alarm will appear and press “**ENT**”. Maximum setting is 17 hours and 59 minutes.

The next screen is the “**WHEN TO ACTIVATE**” screen. Select “1” **ABOVE SETPOINT** to turn on the blowdown relay when the conductivity rises above the cycles of concentration setpoint, or select “2” **BELOW SETPOINT** to turn on the blowdown relay when the conductivity falls below the cycles of concentration setpoint

13.6 By Multi-Setpoint

This option is only available if a conductivity node (NCON) is installed as the MAKEUP COND input.

If the NIN is installed with a conductivity node installed as the MAKEUP COND input the BLOWDOWN relay can be configured to blow down based on multiple setpoints instead of a single tower setpoint. There are three different setpoints that can be established based on the value of the makeup water conductivity.

The user programs three ranges of makeup water conductivity and a setpoint for each of the three ranges. The controller determines which of the three setpoints to use based on the conductivity of the makeup water conductivity.

When **BY MULTI-SETPOINT** is selected in the blowdown relay setup screen the **MULTI-SETPOINT** screen is displayed.

```

      MULTI-SETPOINT
=====
1 SETPOINTS/RANGES
2 DEADBAND
3 BLOWDOWN TIMEOUT

```

- Press "1" **SETPOINTS/RANGES**

```

      SETPOINTS / RANGES
=====
1 1000, 0000 - 0300
2 1500, 0300 - 0500
3 2000, 0500 - UP

```

- Establish a setpoint for three ranges of makeup water conductivity. The first range always starts at 0 μ S. The second range starts at the top of the first range. The third range is any conductivity above the second range.

13.7 Configuring Relays 2,3 and 4

Below is the **RELAY OPTIONS** screen. The asterisk (*) next to one of the options tells you how that relay is configured. Relays 2, 3, and 4 can be programmed in each of the methods shown on the **RELAY OPTIONS** screen.

```

          RLY2
          =====
1*DISABLED
2 SETPOINT
3 WATER METER
4 PERCENT BLOWDOWN
5 PERCENT OF TIME
6 CALENDAR TIMER
7 ALARM RELAY
8 CHANGE MY NAME
9 SCHEDULED LOCKOUT?

```

13.7.1 Disabled

Relays 2, 3, and 4 can be disabled. When a relay is disabled, it will not energize automatically.

From the **RELAY OPTIONS** screen press “1” **Disabled** to disable the relay

13.8 By Setpoint

Relays 2, 3, and 4 can be configured to operate based on a ORP or conductivity setpoint.

To set up the relay to operate based on a setpoint, select **SETPOINT** in the RELAY OPTIONS screen. A screen asking **WHICH PROCESS?** will appear. Select ORP or conductivity. If conductivity is selected the following screen will appear.

```

          SETPOINT=
          1000 µs

          DEADBAND=
          20 µs
          CAL: +/-  ENT: ACCEPT

```

13.8.1 Setpoint

In the **SETPOINT** screen you will set the **SETPOINT**, the **DEADBAND** and the **OVERFEED TIME** alarm.

The **SETPOINT** is the conductivity or ORP value that you are trying to maintain. Check with your water treatment engineer to determine the conductivity and ORP setpoints for your system needs.

Follow these instructions to establish the controller's setpoint:

- Use the keypad numbers to enter the proper ORP or conductivity setpoint and press “**ENT**”. When finished, you will automatically be moved down to the deadband.

13.8.2 Deadband

After the setpoint is established, the relay's deadband must also be set. "**Deadband**" refers to the amount of conductivity or ORP above and below the setpoint—a range within which the controller will not react. Due to continuous fluctuations in the conductivity and ORP level, it is necessary to have this deadband range or stable readings will be difficult to obtain. The Deadband should be a small percentage of the setpoint. Half the deadband amount will be automatically put above the setpoint, and the other half below it.

For example, a Conductivity setpoint of 1000 μS with a deadband of 20 μS would result in the relay turning on at 1010 μS and turning off at 990 μS .

- Use the keypad numbers to enter the proper deadband setpoint and press "**ENT**". When finished, you will automatically be switched to the **OVERFEED TIME** alarm screen.

13.8.3 Overfeed Time

The **OVERFEED TIME** alarm is designed to notify the operator of a problem in the chemical feed system such as, a pump has lost its prime or there is no chemical in the drum. It will also protect the system from overfeeding chemical when the indicated conductivity or ORP does not display a change in actual conductivity or ORP. The **OVERFEED** timeout function will display a visual alarm on the display and **it will turn off the relay**. If a relay is configured as an alarm relay, the **OVERFEED TIME** alarm will energize the alarm relay. To disable this function set the **OVERFEED** time to 0:00.

Use the keypad numbers to enter the time in hours and minutes before this alarm will appear and press "**ENT**". Maximum setting is 17 hours and 59 minutes.

13.8.4 When to Activate

After configuring the SETPOINT, the DEADBAND, and the OVERFEED alarm, the controller will automatically move to the **WHEN TO ACTIVATE** screen. To set up to feed chemical on a rising ORP or conductivity set the relay to activate *above* the setpoint. To set up to feed on a falling ORP or conductivity set the relay to activate *below* the setpoint.

<p>WHEN TO ACTIVATE =====</p> <p>1 *ABOVE SETPOINT 2 *BELOW SETPOINT</p>
--

- Select "**1**" **ABOVE SETPOINT** to turn on the relay when the ORP or conductivity rises above the ORP or conductivity setpoint, or select "**2**" **BELOW SETPOINT** to turn on the relay when the ORP or conductivity falls below the ORP or conductivity setpoint

13.8.5 By Water Meter

Relays 1, 2, 3, and 4 can be configured to operate for a specified amount of time based on a specified amount of flow through the water meter inputs. **MTR1**, **MTR2** or the sum of **BOTH** water meter inputs can activate the relay.

We select 10% of the time, our controller operates 24 hours a day and our chemical pump flow rate is 1 gallon per hour.

$$10\% \times 24 \frac{\text{hours}}{\text{Day}} \times \frac{1 \text{gallon}}{\text{Hour}} = \frac{2.4 \text{ Gallons}}{\text{Day}}$$

- From the **RELAY OPTIONS** screen press "4" **PERCENT OF TIME**.
- Use the keypad to enter the percentage of time desired. Press "ENT".

13.8.8 By Calendar Time

The Calendar Timer is used to feed chemicals such as biocides on a time of day basis. Setting up the Calendar Timer is a two-part process. The first part is to configure the relay so that it will operate by Calendar Timer. The second part of the process is to configure the Calendar Timer. The Calendar Timer is covered in section 14.

- From the **RELAY OPTIONS** screen press "6" **CALENDAR TIMER**.

The controller will respond with the following screen.

SCHEDULED RELAY

SEE MAIN MENU
FOR CALENDAR TIMER

PRESS ANY KEY

The relay has been configured to operate based on a Calendar Timer but, the relay will not activate because the Calendar Timer has not been programmed yet.

13.8.9 As an Alarm Relay

Relays 2, 3, and 4 can be configured as alarm relays. The alarms that will cause the relay to activate are selectable from the controller alarms or from any node input alarms. The controller alarms include: **HIGH CONDUCTIVITY, LOW CONDUCTIVITY, FOULED CONDUCTIVITY SENSOR, SHORTED TC, OPENED TC, HIGH ORP, LOW ORP, HIGH REFERENCE IMPEDANCE, OPEN PT BAND, HIGH REFERENCE VOLTAGE, LOW REFERENCE VOLTAGE, MAX BD TIME EXCEEDED, FEED SEQUENCE ACTIVE, RELAY #2 TIME EXCEEDED, RELAY #3 TIME EXCEEDED, RELAY #4 TIME EXCEEDED,** and the **NO FLOW** alarm.

From the **RELAY OPTIONS** screen press "7" **ALARM RELAY**. The controller will respond with the following screen.

WHICH ALARMS?

=====

1 CONTROLLER
2 RELAYS 5-8
3 RELAYS 9-12
4 MAKEUP COND
5 REMOTE SENSOR
6 REMOTE SENSOR
7 REMOTE SENSOR
8 REMOTE SENSOR

```
9 ANALOG INPUTS (4)
10 ANALOG INPUTS (4)
11 DIGITAL INPUTS (4)
12 DIGITAL INPUTS (4)
```

Select the alarms from this menu that will activate the relay.

13.8.10 Change Relay Name

The name of each individual relay can be changed to any 4-character name. This is useful to designate the chemical name for each relay. Use the arrow keys to change the character and the ENT key to move to the next character.

```
OLD NAME=
  RLY2

NEW NAME=
  OXID

<UP><DOWN>ENT: ACCEPT
```

From the **RELAY OPTIONS** screen press "7" **CHANGE MY NAME.**

13.8.11 Scheduled Lockout

This setting allows the user the choice of whether to lock out a relay during a scheduled feed sequence or not. If you do not want to lock out this relay during a scheduled feed sequence select **NO**.

```
LOCK OUT RELAY DURING
SCHEDULED FEED?

=====
1 * YES
2 NO
```

- From the **RELAY OPTIONS** screen press "9" **SCHEDULED LOCKOUT?**
- Press "1" **YES** to lock out the relay during a scheduled feed or press "2" **NO** to allow the relay to operate normally during a Calendar Timer.

Note: This setting is only available and visible when the relay is set to operate based on SETPOINT, WATER METER, PERCENT OF BLOWDOWN, or PERCENT of TIME

14 Setting up The Calendar Timer

Refer to section 13.7 to configure a relay to feed based on the Calendar Timer before continuing with this section.

To get to the Calendar Timer menu:

From the **MAIN MENU** press "3" **CALENDAR TIMER**. You will see the following screen:

```

          CALENDAR TIMER
          =====
1 *BY WEEKDAY
2 BY CYCLE CALENDAR
3 LIST SCHEDULE

```

The Calendar Timer can be programmed to feed chemicals by either **WEEKDAY** or by a **CYCLE CALENDAR** basis.

BY WEEKDAY is used to feed chemicals by the weekday name, i.e. Monday, Tuesday, Wednesday etc.

This is a seven-day schedule. At the end of the week, the schedule starts over again. To configure the Calendar Timer to feed by weekday:

- From the **CALENDAR TIMER** screen, press "1" **BY WEEKDAY**.

BY CYCLE CALENDAR is used to feed chemicals by a schedule other than one that is seven days long. **BY CYCLE CALENDAR** can be used to feed the same chemical every day or up to 28 days between feedings. The operator specifies the number of days in the cycle calendar. After the cycle calendar is completed, the schedule starts over again. This method of feeding is particularly useful when feeding two biocides on alternating weekly basis. To configure the Calendar Timer to feed by cycle calendar:

From the **CALENDAR TIMER** screen, press "2" **BY CYCLE CALENDAR**.

Use the keypad to enter the number of days in your cycle then press "ENT". Remember the maximum number of days allowed is 28.

Use the keypad to enter which day today is in your cycle, e.g. today is day number 5 in my 14 day cycle, then press "ENT".

After selecting whether the Calendar Timer will be fed by **WEEKDAY** or by **CYCLE CALENDAR** it is time to actually program the schedule. To enter the actual Calendar Timer or to edit the Calendar Timer from the Calendar Timer screen above:

Press "3" **LIST SCHEDULE**. This will take you to a list of all scheduled feeds as shown in the screen on the next page.

NOTE: The maximum number of scheduled feeds is 16 (sixteen) total.

```

          CALENDAR TIMER
          =====
1 01 03:00 RLY2
2 00 00:00
3 00 00:00
4 00 00:00
5 00 00:00

```

6 00 00:00

- If there are no scheduled feeds, select the first schedule and press "ENT". If you are editing the schedule, select the schedule that you want to edit and press "ENT".

Below is an example screen for programming a chemical feed. **Before programming a chemical feed, you need to configure Relay 2, 3, or 4 to be a Calendar Timer relay.**

RELAY (ARROWS) : NONE
CYCLE DAY : 0
START TIME : 00:00
COND SETPOINT : 0
BLOW DURATION : 00:00
FEED DURATION : 00:00
LOCKOUT TIME : 00:00
<UP><DOWN>ENT: ACCEPT

- To program the schedule use the keypad to enter the values in the above screen. Press "ENT" to move to the next item.

NOTE: ALL TIMES ARE IN HOURS AND MINUTES

RELAY is which relay you want to program (you must configure a relay to be a Calendar Timer relay first). Use the arrow keys to select the available relays. Only relays that have been configured as Calendar Timer relays will appear.

CYCLE DAY or DAY is the day you wish to actuate the Calendar Timer relay.

START TIME is the time you want to start the Calendar Timer sequence. This start time uses the 24 hour clock or military time. **06:00:00** is 6 a.m. **18:00:00** is 6 p.m.

COND SETPOINT is a pre-bleed setpoint. This would typically be lower than the normal conductivity setpoint. Because the bleed valve may be disabled during a scheduled feed, a pre-bleed will help prevent a build up of tower conductivity. 0 μ S will disable this feature. **BLOW DURATION** if the COND SETPOINT is not met within this time, the blowdown will stop and the Calendar Timer relay will be actuated. **If conductivity is disabled, this is the amount of time the controller will blow down during the pre-bleed sequence.** Inputting 0:00 will disable this feature. Pulsafeeder recommends that some time be entered if pre-bleed is used.

FEED DURATION is the amount of time the Calendar Timer relay will be on.

LOCKOUT TIME after the feed duration is completed, an additional lockout time for RLY 1, 2, 3, and 4 relays can be programmed. The lockout time

prevents the other relays from operating until this time expires.
Setting this time to 0:00 will disable this feature.

15 Alarms

The Model 3323 is equipped with both high and low conductivity and ORP alarms. This menu option allows you to program the specific values for these alarms. When a conductivity or ORP alarm is received, it will appear as a flashing message in the middle of the display and any configured alarm relays will be activated. **The high conductivity alarm will override the blowdown relay and force a blowdown to occur.** Consult your water treatment specialist when determining the proper High and Low Alarm values for your system.

To set the alarm setpoints:

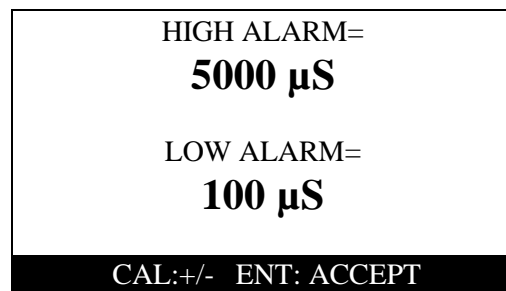

- From the **MAIN MENU** press "4" **ALARMS**. A screen asking **WHICH PROCESS?** will appear. Select ORP or conductivity.
- Use the keypad to enter a value for the high alarm. Press "ENT".
- Use the keypad to enter a value for the low alarm and press "ENT".

Use the keypad to enter a value for the deadband and press "ENT". Refer to section 13.8.2 for a discussion on deadband.

16 Water Meter

The 3300 series controllers will work directly with the following types of meters: dry contacting head meters, Seametrics open collector output meters, Signet 2535 and 2540 paddle wheel meters, and the Autotrol 1 inch and 2 inch meters. Contact Pulsafeeder for other types of water meters.

Both water meter inputs are programmed in the same manner.

To get to the water meter configuration screen:

- From the **main menu**, press "5" **WATER METERS**. This will take you to the **WHICH WATER METER SCREEN**.
- Press "1" for **MTR1** or press "2" for **MTR2**.
- This will take you to the **WATER METER TYPES** screen as shown.

WATER METER TYPES	
=====	
1	CONTACTING HEAD
2	PADDLE WHEEL
3	DATA INDUSTRIAL
4	SIGNET
5	AUTOTROL TURB 1 IN.
6	AUTOTROL TURB 2 IN.
7	CHANGE MY NAME

- Use the keypad to select the type of water meter that you are using.

The next screen is the **UNITS OF VOLUME** screen.

- The water meters can be configured for gallons or liters. Press "1" for **GALLONS** or press "2" for **LITERS**.

If **CONTACTING HEAD** was selected:

- You will be taken to the **GALLONS OR LITERS PER CONTACT** screen. Use the keypad to enter the number of gallons or liters per contact for your specific meter then press "ENT". You will then be asked if you want to reset the total count for that meter to zero. Press "1" for **YES** or press "2" for **NO**.

If **PADDLE WHEEL** was selected:

- You will be taken to the **PULSES PER GAL/LITER** screen. Use the keypad to enter the pulses per gal/liter for your particular water meter then press "ENT". You will then be asked if you want to reset the total count for that meter to zero. Press "1" for **YES** or press "2" for **NO**.

If **DATA INDUSTRIAL** was selected:

- You will be taken to the **SLOPE VALUE** screen. Use the keypad to enter the K factor and offset values for your particular water meter then press "ENT". You will then be asked if you want to reset the total count for that meter to zero. Press "1" for **YES** or press "2" for **NO**.

If **SIGNET** was selected:

- You will be taken to the **K-FACTOR** screen. Use the keypad to enter the K-factor for your particular water meter then press "ENT". You will then be asked if you want to reset the total count for that meter to zero. Press "1" for **YES** or press "2" for **NO**.

If **AUTOTROL TURB 1 IN.** was selected:

- The controller will confirm that the **AUTOTROL TURB 1 IN.** has been selected and you will be asked if you want to reset the total count for that meter to zero. Press "1" for **YES** or press "2" for **NO**.

If the **AUTOTROL TURB 2 IN.** is selected:

The controller will confirm that the **AUTOTROL TURB 2 IN.** has been selected and you will be asked if you want to reset the total count for that meter to zero. Press "1" for **YES** or press "2" for **NO**.

17 Set-up the 4-20mA Output

If the 4-20mA option is ordered the controller will have two channels of 4-20 mA outputs. The 4-20mA is an option card that can be added in the field.

17.1 Set Up of the 4-20mA Output

To set up the 4-20 mA output:

- From the **Main Menu**, press "6" **4-20 mA OUTPUTS**

4-20 MA OUTPUT	
=====	
1	420A
2	420B

- Press "1" For **channel A** 4-20 mA OUT SETUP. Press "2" For **channel B** 4-20 mA OUT SETUP

The **4-20 mA Out Setup** screen allows the user to set the 4-20 mA range, calibrate the 4-20 mA output, select which process the 4-20 mA channel will respond to, take manual control of the 4-20 mA output, and change the name of the output. Below is the **4-20 mA Setup** screen.

4-20 MA OUTPUT	
=====	
1	SET 4-20 MA RANGE
2	CALIBRATE 4-20 mA
3	WHICH PROCESS?
4	MANUAL CONTROL
5	CHANGE MY NAME

17.2 Set the 4-20mA Range

The 4-20 mA output range must be set for the output to be useful.

- From the **4-20 mA OUTPUT** screen, press "1" **Set the 4-20 mA RANGE**.
- Use the keypad to enter a conductivity or ORP value for the 4-mA point. Press "ENT".

Use the keypad to enter a conductivity or ORP value for the 20-mA point. Press "ENT".

17.3 Manual Control

Manual control is used to temporarily change the 4-20 mA output.

- From the **4-20 mA Setup** screen, press **"2" MANUAL CONTROL**.

Use the up and down arrow keys to raise or lower the 4-20 mA output. To exit this screen and restore automatic control of the 4-20 mA output press **"BACK"**.

17.4 Which Process

If the controller has any remote sensor nodes attached the 4-20 mA channel can be configured to operate based on that input or conductivity and ORP.

- From the **4-20 mA Setup** screen, press **"3" WHICH PROCESS?**
- Use the up and down arrow keys to select the process that will control the 4-20 mA output. Press **"ENT"**.

17.5 Calibrate the 4-20mA Output

The 4-20 mA needs to be calibrated to the actual output to be accurate. A milliamp meter is necessary to calibrate the 4-20 mA output. Connect the milliamp meter in-line with one leg of the 4-20 mA output. Refer to the drawing in the back of this manual for wiring instructions.

- From the **4-20 mA Setup** screen, press **"2" CALIBRATE**.
- Use the keypad to enter the milliamp reading from the milliamp meter for the **4-mA** point. Press **"ENT"**.

Use the keypad to enter the milliamp reading from the milliamp meter for the **20-mA** point. Press **"ENT"**.

17.6 Change 4-20mA Name

The name of the 4-20 mA output can be changed by the operator.

- From the **4-20 mA Setup** screen, press **"5" CHANGE MY NAME**.

Use the arrow keys to change the characters, use the ENT key to move the cursor to the next character.

18 System Set-up Menu

The system setup menu is used to set up the name of the process, damping, initialize the controller, digital inputs, check the firmware version, change the security passwords, check the diagnostics, set up the communications, and node installation.

18.1 Process Parameters

The process parameters screen is used to change the name of the process, and set the damping.

18.2 Change Process Name

The name of the process can be changed from to any 4-character name.
To change the name of the process:

- From the Main Menu press **"7" SYSTEM SETUP**.
- Press **"1" PROCESS PARAMETERS**.
- Press **"1" CHANGE MY NAME**.

Use the arrow keys to change the characters, use the ENT key to move the cursor to the next character.

18.3 Damping

The rate of change of the ORP value can be slowed down using DAMPING. If the ORP value is changing quickly you can slow it down by:

From the **Main Menu** press **"7"** **SYSTEM SETUP**.
Press **"1"** **PROCESS PARAMETERS**.
Press **"4"** **DAMPING**.

Use the keypad to change the DAMPING value. Input a larger number to slow the rate of change down or a smaller number to speed it up. Press **"ENT"**.

18.4 Initialization

Initialization restores the factory default settings to the controller. The whole controller can be initialized or just the calibration. It is suggested that you initialize the whole controller before you program the controller. This will clear any random settings that may be in the controller. To do so, follow these instructions:

From the **Main Menu**, press **"7"** **SYSTEM SETUP**.
Press **"2"** **INITIALIZATION**.
Press **"2"** **WHOLE CONTROLLER** and press **"ENT"**. A warning will appear on the screen (see below). Press **"1"** to proceed, **"2"** to cancel.

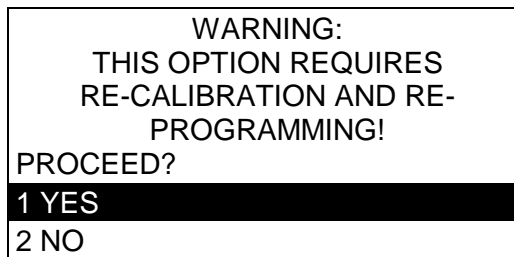

To initialize just the calibration:

Press **"1"** **CALIBRATIONS** instead of **"2"** **WHOLE CONTROLLER** in the procedure above. The same warning screen will appear.

18.5 Digital Inputs

If the controller has a digital input node (NDIG) installed the inputs are configured from this screen. If a NDIG is not installed there is no access to this menu item. Configuration of the digital inputs are covered in the NDIG manual.

18.6 Firmware Version

Sometimes it is necessary to verify the firmware version of the controller for troubleshooting purposes. To obtain the firmware versions:

From the **Main Menu**, press **"7"** **SYSTEM SETUP**.
Press **"4"** **FIRMWARE VERSION**.

The firmware versions will be displayed. Use the arrow keys to see all firmware versions. To exit this screen, press **"BACK"**.

18.7 Change the Security Passwords

The security password can be changed from the factory default settings to any four-digit value of your choice.

To change the security passwords:

From the **Main Menu**, press **"7"** **SYSTEM SETUP**.
Press **"5"** **SECURITY**.

```
CHANGE PASSWORD
=====
1 OPERATOR
2 TECHNICIAN
```

Press **"1"** **OPERATOR** to change the operator password or Press **"2"** **TECHNICIAN** to change the technician password.

Use the keypad to enter the old password. If the password has not been changed before, the old password for **OPERATOR** is **1111** and the password for **TECHNICIAN** is **2222**.

Use the keypad to enter the new password.

Use the keypad to enter the new password a second time for verification

If you lose your password, contact Pulsafeeder for assistance.

18.8 Diagnostics

The diagnostics screen is used for troubleshooting purposes. Contact Pulsafeeder for assistance.

18.9 Communications

The controller has an option for remote communications, the RS-232 option. If this option is installed the communications option is configured from this screen. This screen is used to set up the com port, initialize the modem, and set the remote password.

To set up the communications option:

From the **Main Menu**, press **"7"** **SYSTEM SETUP**.
Press **"7"** **COMMUNICATIONS**.

```
COMMUNICATIONS
=====
1 COM PORT SETUP
2 INITIALIZE MODEM
3 REMOTE PASSWORD
```

18.10 Com Port Set-up

Com port setup is used to set up the com port for use with a modem or direct connect.

To set up the com port press “1” **COM PORT SETUP**

```
COM PORT PARAMETERS
=====
BAUD RATE: 19200
DATA BITS: 8
STOP BITS: 1
PARITY : NONE
<UP><DOWN> ENT: ACCEPT
```

Use the arrow keys to change the baud rate. If using the direct connect method of communicating, ensure that the baud rate at the controller and the baud rate in the LRWS software match.

The standard values for the **DATA BITS** is 8, **STOP BITS** is 1, and **PARITY** is NONE. Normally these will not need to be changed.

18.11 Initialize Modem

Before a modem can be used by the controller it must be initialized. The initialization screen gives four choices of modems.

To initialize the modem:

- From the Communications menu, press “2” **INITIALIZE MODEM**

```
INITIALIZE MODEM
=====
1 HAYES ACCURA
2 U.S. ROBOTICS
3 ZOOM
4 OTHER MODEM
```

Select your modem from the list. If your modem is not listed and you select **OTHER MODEM** use the keypad to enter the initialization string for your modem.

If the modem fails to initialize, check the 25-pin connector, the phone cable, the modem, and the RS-232 option card.

18.12 Remote Password

Remote communications to the Pulsafeeder 3300 series controllers is protected with an 8-digit password. The remote password is required to make changes to the controller using the communications option card.

The remote password screen in the communications menu is used to change the remote password. The remote password can only be changed at the controller.

To change the remote password:

- From the communications menu, press “3” **REMOTE PASSWORD**.
- Use the keypad to enter the old password. Enter the new password. Repeat the new password again for verification. **NOTE: The default password is 12345678.**
- Set the remote password in the LRWS program to match the new password for this controller.

18.13 Node Installation

The node installation menus is used to install new nodes and to de-install installed nodes. Please refer to your node manual for information on node installation.

19 Setting the Clock

The clock uses the 24 hour or military time. **06:00:00** is 6 a.m. **18:00:00** is 6 p.m. To set the clock:

- From the **Main Menu** press "8" **CLOCK**. The following screen will appear:

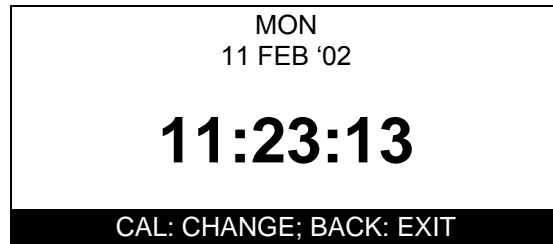

- Press "**CAL**" to change the clock settings.
- Use the up and down arrow keys to change the day of the week. Press "**ENT**".
- Use the number keys to change the date. Press "**ENT**".
- Use the arrow keys to change the month. Press "**ENT**".
- Use the number keys to change the year. Press "**ENT**".
- Use the number keys to change the hour. Press "**ENT**".
- Use the number keys to change the minutes. Press "**ENT**".
- Use the number keys to change the seconds. Press "**ENT**".
- Press "**BACK**" to exit this screen.

You must press "**ENT**" all the way through this menu for the settings to take affect.

20 Changing the Security Levels

The security level can be change to prevent any unwanted tampering of the controller. To change the security level from **Technician** to **Operator** or **View-Only**:

- From the **Main Menu**, press "0". (*Note that "0" does not appear on the menu screen.*)

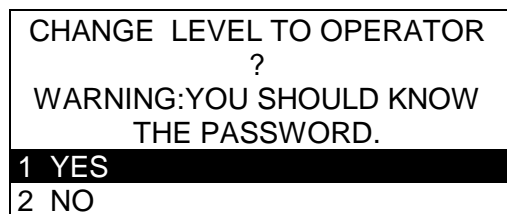

- Select **YES** to change the security level to a more restrictive level.

The controller menu now functions at the new security level.

To return to the **Technician** security level:

- Press the numeric password from the **Process** screen:



Remember that following the first power-up the Technician password is 2222 and the Operator password is 1111. You may change the passwords in the SYSTEM SETUP menu.

21 Maintenance

Periodic maintenance is required to ensure trouble free operation of the controller. The following sections cover the required maintenance.

21.1.1 Conductivity sensor

- Remove power from the controller and shut off the sample flow.
- Remove the sensor from its plumbing.
- Clean the electrodes with a wire brush. A soft steel brush is preferable to a brass brush. Do not use cloth to clean the electrodes. Cloth has oils that will foul the sensor.
- If there is oil on the sensor glass, use isopropyl alcohol to clean the electrode.
- It is recommended that you use a 10% Muriatic or HCL acid to clean the sensor if necessary.
- Wash the sensor off with tap water.
- Install the sensor in its plumbing.
- Restore sample flow and check for leaks.
- Restore power to the controller.
- Perform a calibration of the Conductivity.

21.1.2 ORP Sensor

Clean the electrode end of the ORP sensor at least once per month. Cleaning of the ORP sensor may need to be performed more frequently if it is in a high fouling environment.

- Remove power from the controller and shut off the sample flow.
- Remove the sensor from its plumbing.
- Be careful not to touch the glass electrode. Do not use cloth to clean the electrode. Cloth has oils that will foul the sensor.
- If there is oil on the sensor glass, use isopropyl alcohol to clean the electrode.
- It is recommended that you use a 10% Muriatic or HCL acid to clean the sensor.
- Wash the sensor off with tap water.
- Install the sensor in its plumbing.
- Restore sample flow and check for leaks.
- Restore power to the controller.
- Allow the reading to stabilize for approximately 30 minutes.
- Perform a calibration of the ORP.

21.2 Flow Switch Maintenance

If you have the flow switch plumbing assembly, you may need to periodically clean the wetted parts in this assembly.

- Shut off the inlet flow and the power to the controller.
- Turn the coupling nut for the flow switch counterclockwise.
- Pull out the red shuttle with your fingers.
- Use a bottlebrush on the shuttle, flow sight and the flow switch assembly to remove any residue.
- Clean and lubricate the “O” ring with a silicone-based lubricant (petroleum-based lubricants will cause the O-ring to swell).
- Tighten down the coupling nut after you replace the components.
- Turn the inlet flow back on and check for leaks.

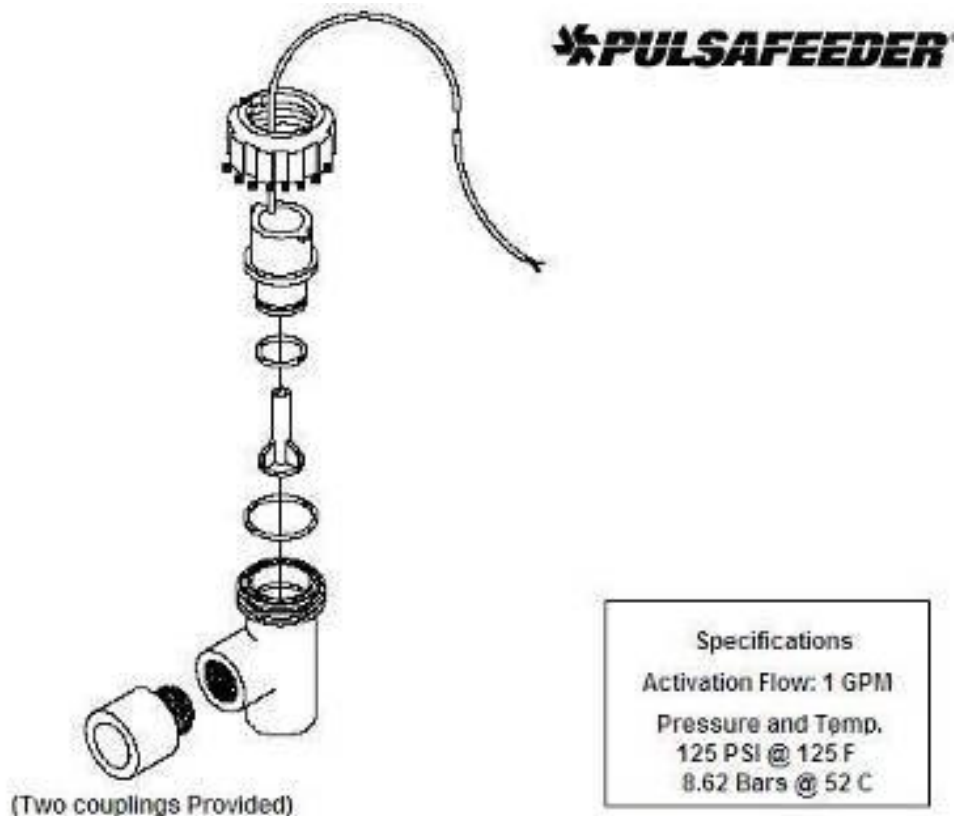

P/N 04-350-90-1 Flow Switch Assembly

22 Replacing the Fuses

The controller contains a 10A, 250V fuse. The fuse holder is located on the bottom of the enclosure. It is accessible from the outside of the box. Replacement fuses must be a fast blow type. If the fuse is blown, the display will be blank and the four power supply lights inside the controller enclosure will be dark when the unit is connected to power. Refer to the troubleshooting section of this manual for more information about blank displays.

23 Troubleshooting

23.1 Error Messages

This section discusses some of the more common questions. These notes are not intended to be all-inclusive—only to cover the most common situations. If you have other questions or need support, contact the Pulsafeeder Technical Service Department toll free at (800) 333-6677.

PROBLEM	WHAT THIS MEANS	CORRECTIVE ACTION
{Alarm Flashing} “Conductivity: HIGH ALARM”.	Conductivity is too high with respect to the high alarm setpoint.	<ol style="list-style-type: none"> 1. Check the High Alarm Value. 2. Check relay setpoints and deadbands. 3. Check operation of bleed-off valve. Use the manual relay control to help. 4. Check blowdown valve is not stuck closed or the line is restricted.
{Alarm Flashing} “Conductivity: LOW ALARM”.	Conductivity is too low with respect to the low alarm setpoint.	<ol style="list-style-type: none"> 1. Check the Low Alarm Value. 2. Check relay setpoints and deadbands. 3. Check blowdown valve is not stuck open. 4. Check that the system is not overflowing.
Water meters not accumulating.	<p>There may be a problem with the wiring or the reed switch in the meter may be bad.</p> <p>For water meters other than the contacting head type, check the manufacturer’s user manual for that particular water meter.</p>	<ol style="list-style-type: none"> 1. Approximately 24 volts DC should be present at the input terminal when the water meter contact is closed. That should change to zero VDC when the contact opens. Check these voltages and for correct wiring. 2. Is the controller configured for your type of water meter?
{Alarm Flashing} “FEED SEQUENCE ACTIVE”.	This simply indicates that a Calendar Timer relay is active.	No action necessary.
Display is blank.	There may be a problem with the incoming power, the fuse or the circuit board. Open the front panel to troubleshoot.	<ol style="list-style-type: none"> 1. Check the fuse. Replace if blown. 2. Does the unit have power? Verify with volt

		<p>meter.</p> <p>3. If there is power to terminals LINE and NEUTRAL on TA, call Pulsafeeder Technical Service for more information.</p>
--	--	---

PROBLEM	WHAT THIS MEANS	CORRECTIVE ACTION
<p>{Alarm Flashing} “RLY: TIME EXCEEDED”.</p>	<p>This indicates that the controller has been trying to feed chemical for longer than the user-programmed time and is unable to reach the setpoint.</p>	<ol style="list-style-type: none"> 1. Check for proper operation of pump or valve. Use the manual relay control to help. 2. Check that the chemical drum is not empty. 3. Check for power to the chemical pump. 4. Verify the relay timeout time is properly set for your application (see RELAYS in MAIN menu). 5. To reset this alarm, momentarily turn off flow to the controller to get the no flow alarm.
<p>“NO FLOW” alarm.</p>	<p>Flow input switch is not closed.</p>	<ol style="list-style-type: none"> 1. The flow switch float may be stuck or no flow is present. 2. Flow switch may be bad. Replace reed switch in plumbing assembly. 3. If no flow switch is used, a jumper wire should be installed across the flow switch input. Removing the jumper disables all relay outputs.
<p>Bleed valve relay is closed above setpoint.</p>	<p>Controller may be in biocide schedule.</p>	<p>Check Calendar Timer.</p>
<p>Bleed valve relay is open below setpoint.</p>	<p>High conductivity alarm will force the bleed valve to open. Controller may be doing a pre-bleed before feeding biocide.</p>	<ol style="list-style-type: none"> 1. Check High conductivity alarm setpoint. Change setpoint if necessary. 2. Check Calendar Timer. Adjust as necessary.

PROBLEM	WHAT THIS MEANS	CORRECTIVE ACTION
“SENSOR READS ZERO”	You are trying to perform a span calibration of the conductivity and the conductivity sensor reads zero.	<ol style="list-style-type: none"> 1. Check wiring. 2. Ensure sensor is full immersed in water. 3. The model 3323 for cooling towers will not accept a span calibration below about 200 μS. Cycle conductivity higher and re-calibrate.
{ALARM FLASHING} “COND:Fouled SENSOR”	Conductivity sensor is not reading properly.	<ol style="list-style-type: none"> 1. Clean sensor. 2. Check wiring. Verify that all connectors are fully mated. 3. Replace conductivity sensor.
{Alarm Flashing} “ORP: HIGH ALARM”.	ORP is too high with respect to the high alarm setpoint.	<ol style="list-style-type: none"> 1. See {RLY: TIME EXCEEDED}. 2. Check the High Alarm Value. 3. Check relay setpoints and deadbands. 4. Check chemical drum levels. 5. Check proper operation of chemical pumps.
{Alarm Flashing} “ORP: LOW ALARM”.	ORP is too low with respect to the low alarm setpoint.	<ol style="list-style-type: none"> 1. See {RLY: TIME EXCEEDED}. 2. Check the Low Alarm Value. 3. Check relay setpoints and deadbands. 4. Check chemical drum levels.
Water meters not accumulating.	<p>There may be a problem with the wiring or the reed switch in the meter may be bad.</p> <p>For water meters other than the contacting head type, check the manufacturer’s user manual for that particular water meter.</p>	<ol style="list-style-type: none"> 1. Approximately 24 volts DC should be present at the input terminal when the water meter contact is closed. That should change to zero VDC when the contact opens. Check these voltages and for correct wiring. 2. Is the controller configured for your type of water meter?

23.2 Factory Service

Your PULSAblue is a state of the art microprocessor based controller. If you are experiencing a problem with your process control instrument, first consult the troubleshooting guide in this manual. If the problem is not covered or cannot be solved, contact Technical Services for assistance:

PULSAFEEDER INC. (SPO)
27101 AIRPORT ROAD
PUNTA GORDA, FL 33982
941-575-3800

Trained technicians are available to diagnose your problem and arrange a solution. Solutions may include purchase of replacement parts or returning the controller to the factory for inspection and repair. All returns require a Return Authorization number to be issued by Pulsafeeder. Parts purchased to correct a warranty issue may be credited after an examination of original parts by Pulsafeeder. Warranty parts returned as defective which test good will be sent back freight collect. No credit will be issued on any replacement electronic parts.

Any modifications or out-of-warranty repairs will be subject to bench fees and costs associated with replacement parts.

Warranty

Pulsafeeder, Inc. warrants control systems of its manufacture to be free of defects in material or workmanship. Liability under this policy extends for 24 months from date of shipment. Electrodes/probes are considered maintenance items and as such are warranted for six (6) months from the date of shipment of the controller. Electrodes/probes purchased as spare parts are warranted for 90 days from date of shipment. The manufacturer's liability is limited to repair or replacement of any failed equipment or part, which is proven defective in material or workmanship upon completion of the manufacturer's examination. This warranty does not include removal or installation costs and in no event shall the manufacturer's liability exceed the selling price of such equipment or part.

The manufacturer disclaims all liability for damage to its products through improper installation, maintenance, use, or attempts to operate such products beyond their functional capacity, intentionally or otherwise, or any unauthorized repair. The manufacturer is not responsible for consequential or other damages, injuries, or expense incurred through the use of its products.

The above warranty is in lieu of any other warranty, whether expressed or implied. The manufacturer makes no warranty of fitness or merchantability. No agent of ours is authorized to provide any warranty other than the above.

Service Guide

When calling Pulsafeeder, please have your controller's complete model number and serial number available, together with the firmware version so that the Technician can better assist you.

Refer to the Ordering Information section of this manual for part numbered replacement parts.

Write your controller's complete model number, serial number, and firmware version here so that you will have them available if you wish to contact a Pulsafeeder technician.

Model Number:

Serial Number:

Firmware Version:

24 Drawings

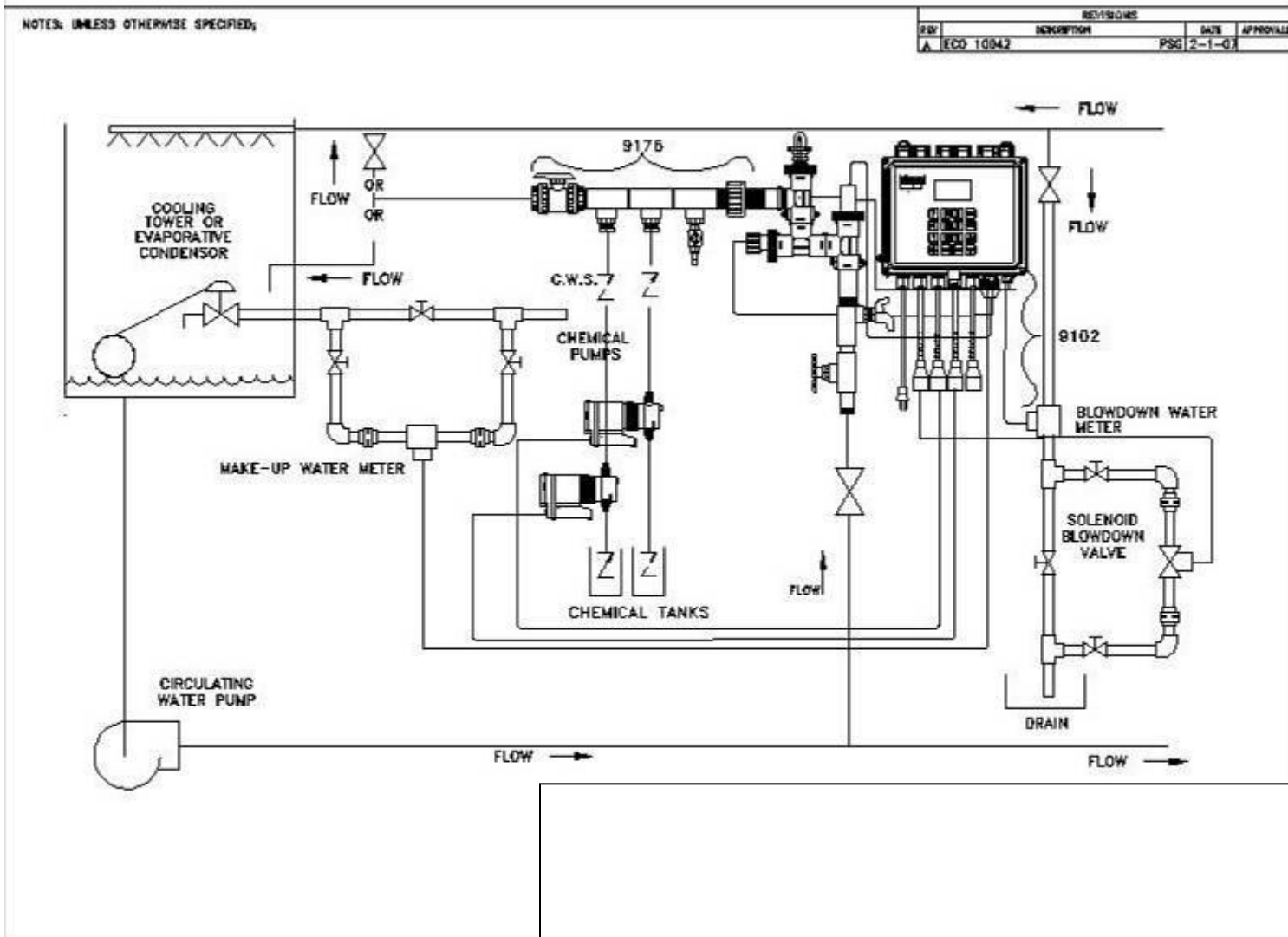

REVISION HISTORY					
REV	DESCRIPTION	EGG	GMH	DATE	APVD
A	IN ACCORDANCE WITH EGG	10042	PSG	9-1-07	

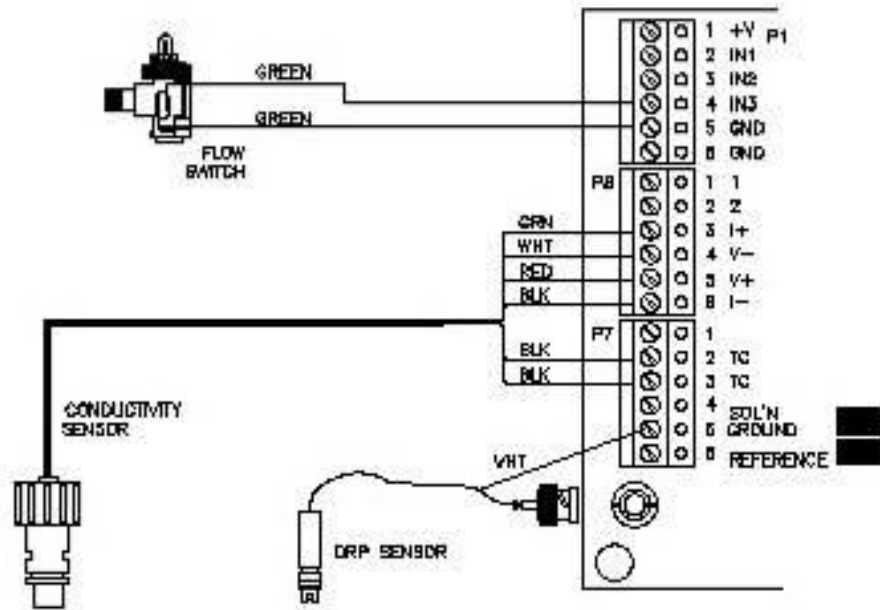

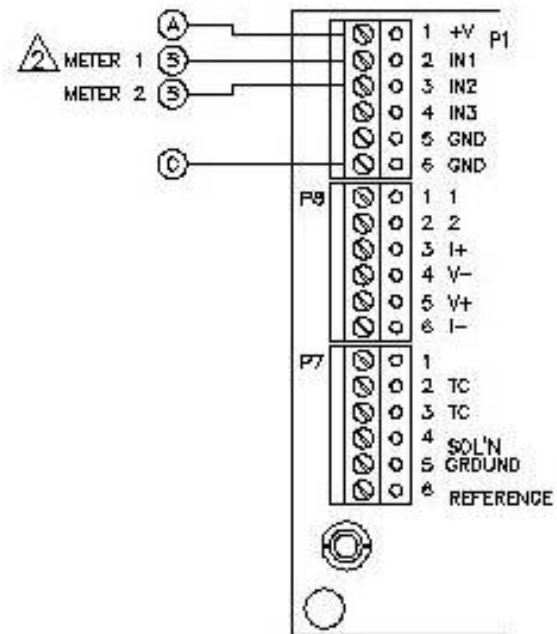
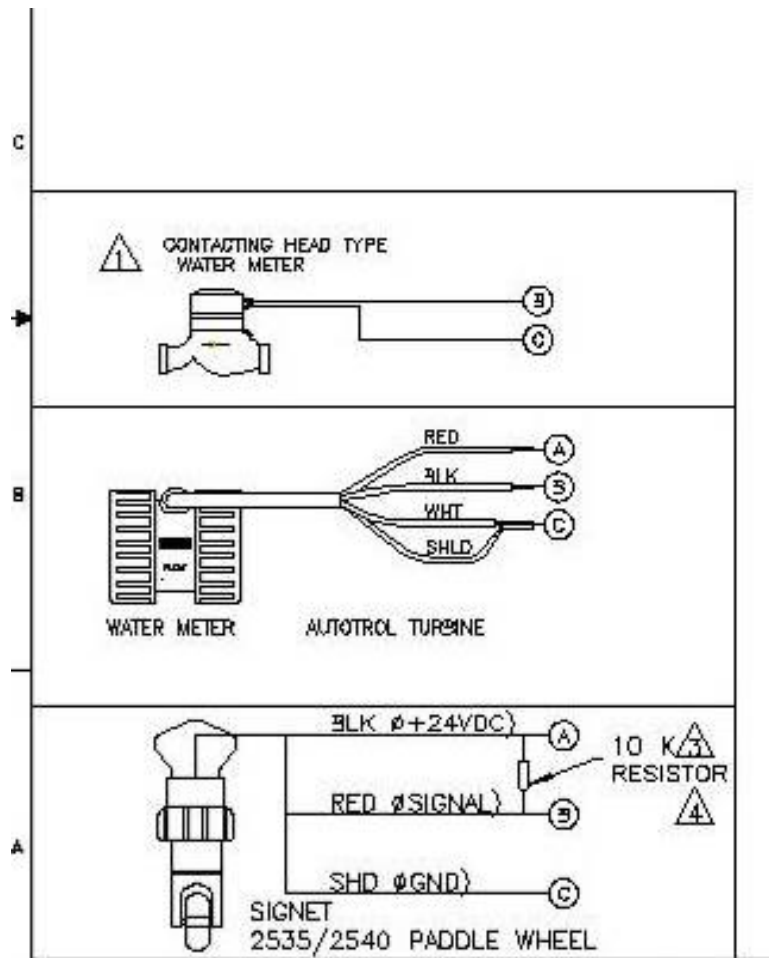

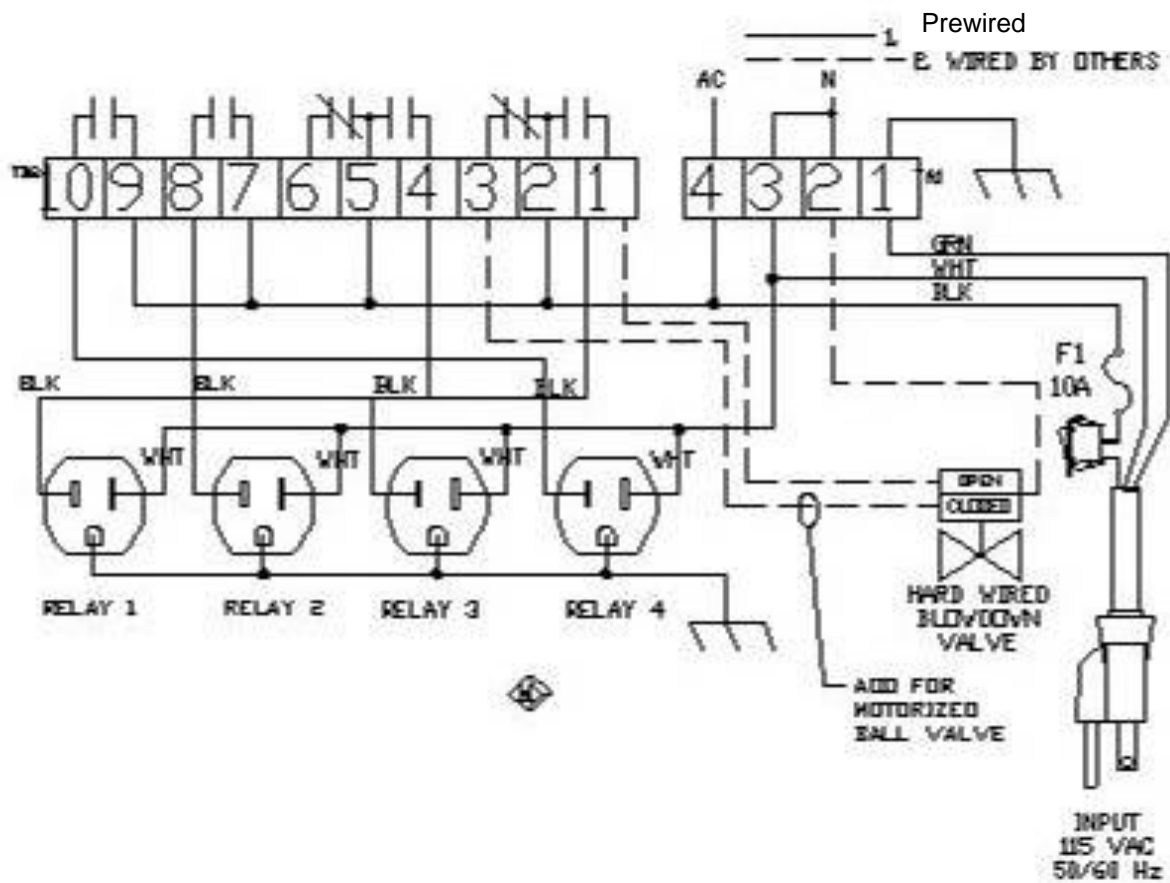

EGG	DWH	DATE	APVD
1004E	PSD	1-16-00	

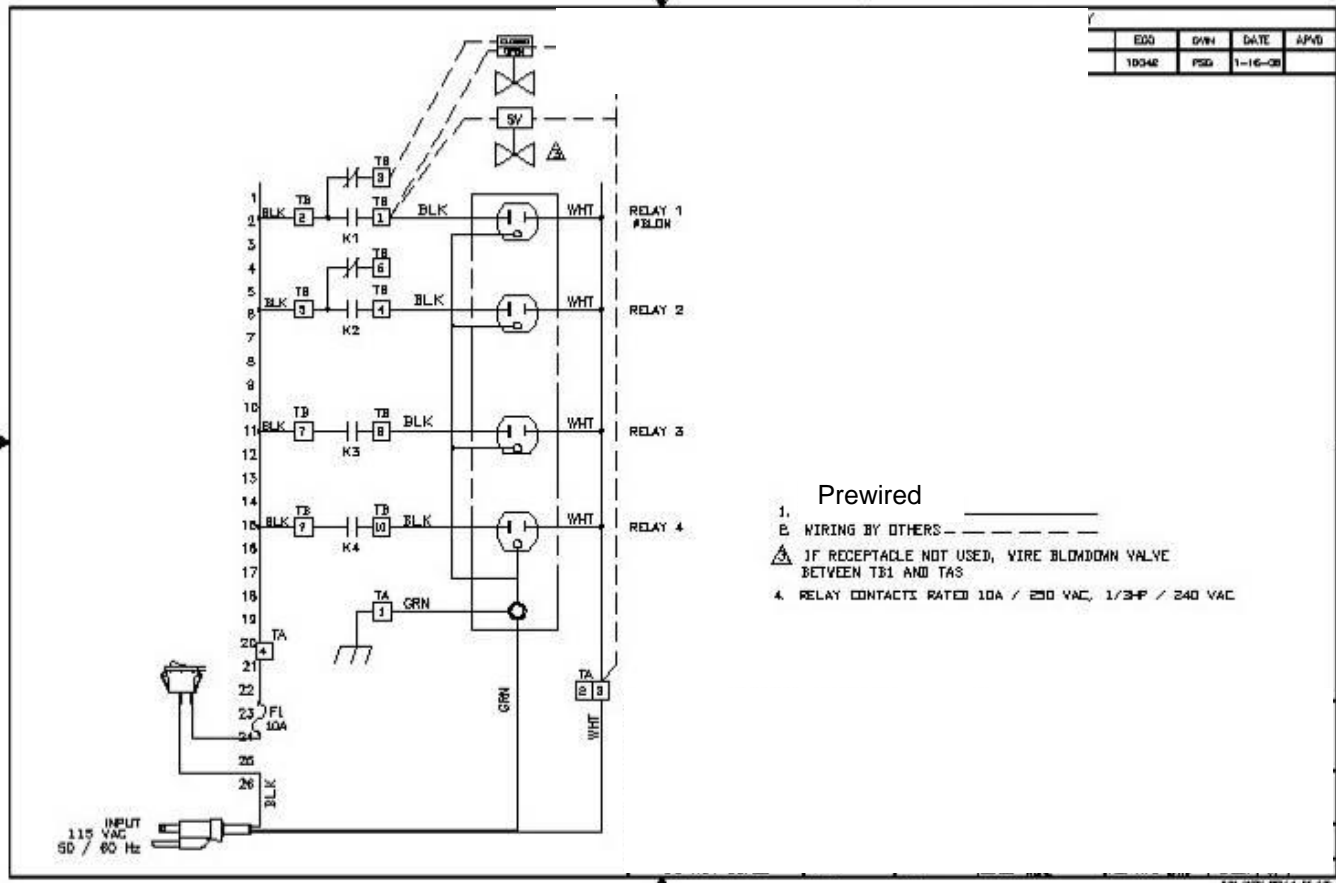

PERSONAL COMPUTER WITH MODEM

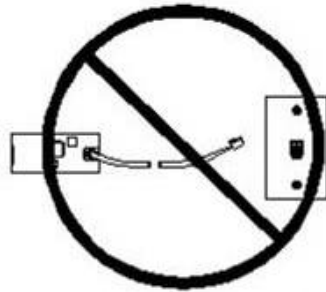
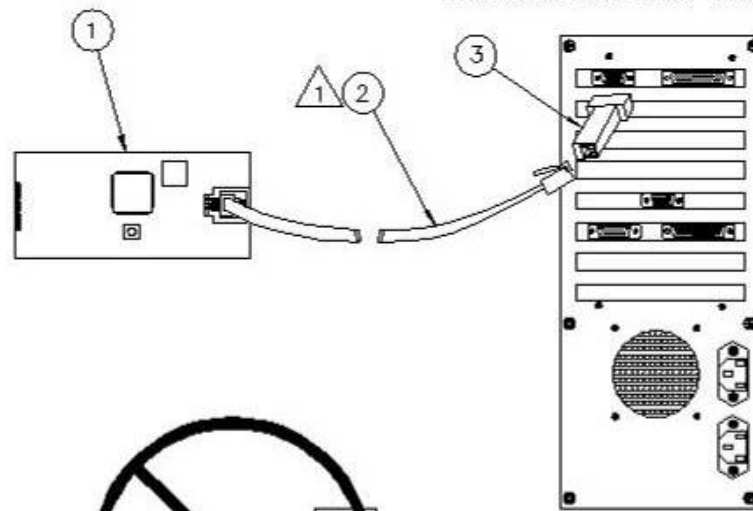

DO NOT PLUG RS2L DIRECTLY INTO TELEPHONE LINES

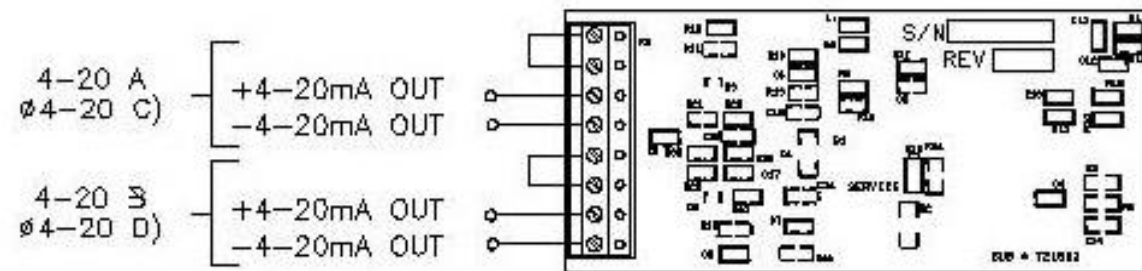

INTERNAL POWER

OPTIONAL EXTERNAL 24 VDC SUPPLY

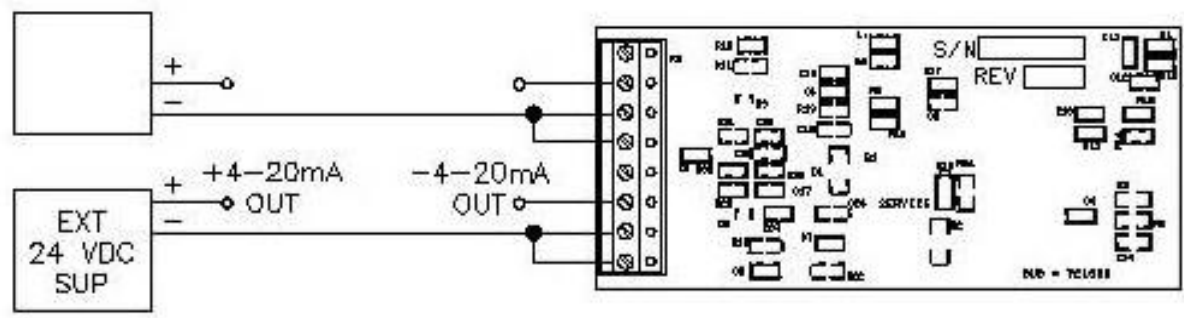

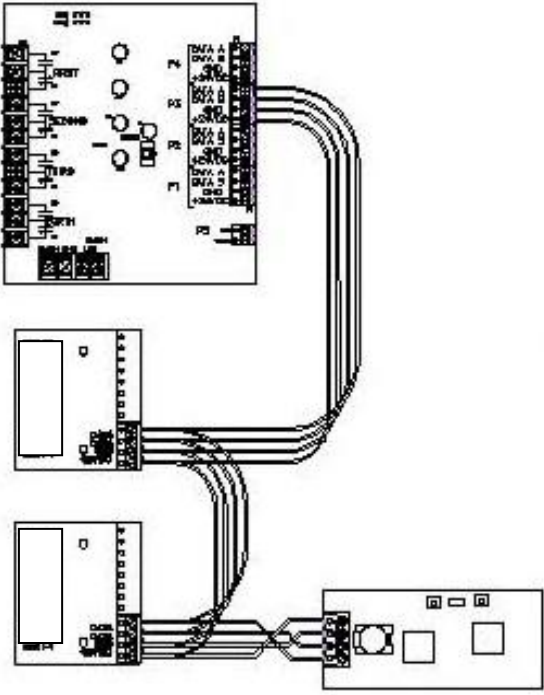

OR

