



DIGITAL GLYCOL FEEDER

DGF1, DGF2

OPERATING INSTRUCTIONS

P/N: 72-900-24 Rev J

(06-22-07)



Manufactures of Quality Pumps,
Controls and Systems

STANDARD PUMP OPERATION
27101 Airport Road
Punta Gorda, FL 33982
Telephone (941) 575-3800
Fax: (941) 575-4085
(800) 333-6677
www.pulsa.com

FACTORY SERVICE POLICY

Your Digital Glycol Feeder (DGF) is designed to make-up lost glycol in a closed loop system. If you are experiencing a problem with your DGF consult the trouble-shooting guide. If the problem is not covered or cannot be solved, please contact your local Pulsafeeder Representative or our Technical Service Department at (800) 333-6677 for further assistance.

Trained individuals are available to diagnose your problem and arrange a solution. Solutions may include purchasing a replacement unit or returning the DGF to the factory for inspection and repair. All returns require a Return Material Authorization (R.M.A.) number to be issued by Pulsafeeder. Pulsafeeder personnel may credit replacements purchased under a possible warranty situation after an examination of the original parts.

Certain components may be purchased for replacement. Pulsafeeder personnel may credit parts purchased to correct a warranty issue after examination of the original parts. Parts returned for warranty consideration that test satisfactorily will be sent back to the originator freight collect.

Any field modifications will void the Pulsafeeder Digital Glycol Feeder warranty. Out-of-warranty repairs will be subject to Pulsafeeder's standard bench fees and testing costs associated with replacement components.

WARRANTY

Pulsafeeder Inc. warrants the Digital Glycol Feeder against defects in materials or workmanship for a period of one year under normal use, from the date of shipment. The manufacturer's liability is limited to the repair or replacement of any failed component that is proven defective in material or workmanship upon manufacturer's examination. This warranty does not include removal or installation costs and in no event shall the manufacturer's liability exceed the selling price of such equipment.

This warranty does not extend to damage by corrosion, erosion, mishandling, any force of nature or any other conditions beyond the seller's reasonable control.

The manufacturer disclaims all liability for damage to its products through improper installation, maintenance, use or attempts to operate such products beyond their functional capacity, intentionally or otherwise or any unauthorized repair. The manufacturer is not responsible for consequential or other damages, injuries or expenses incurred through the use of its products.

The above warranty is in lieu of any other guarantee, either expressed or implied. The manufacturer makes no warranty of fitness or merchantability. No agent of ours is authorized to make any warranty other than the above.

FCC WARNING

This equipment generates and uses radio frequency energy. If not installed and used properly, in strict accordance with the manufacturer's instructions, it may cause interference to radio communications. Operation of this equipment in a residential area is likely to cause interference in which case the user, at his own expense, will be required to take whatever measures necessary to correct the interference.

Copyright

Copyright ©1999 Pulsafeeder, Inc. All rights reserved.

Information in this document is subject to change without notice. No part of this publication may be reproduced, stored in a retrieval system or transmitted in any form or any means electronic or mechanical, including photocopying and recording for any purpose other than the purchaser's personal use without the written permission of Pulsafeeder, Inc.

Table of Contents

1. INTRODUCTION	1
1.1 Systems and Options.....	2
2. INSTALLATION	3
2.1 Assembly.....	3
2.1.1 Tools Required For Assembly.....	3
2.1.2 Pre-Assembly	5
2.1.3 Location	6
2.1.4 Plumbing.....	6
2.1.5 Mounting The Tank.....	7
2.1.6 Mounting The Controller	8
2.1.7 Installing The Level Wand.....	9
2.1.8 Connecting The Pressure Switch.....	10
2.1.9 Connecting The Pump.....	10
2.1.10 Connecting The Re-Circulation Line.....	10
2.2 Electrical Wiring	12
2.2.1 115VAC Pre-Wired Unit Connections	12
2.2.2 115VAC/230VAC Conduit Connections	15
3. GLYCOL FEEDER SYSTEM	23
3.1 User Interface.....	23
3.2 Start Up & Calibration	24
4. OPERATION	28
4.1 Operating Modes	28
4.1.1 Normal.....	28
4.1.2 Feeding Glycol	28
4.1.3 Alarm.....	28
5. SPECIFICATIONS	29
5.1 Environment.....	29
5.2 Power Requirements.....	30
5.3 Inputs.....	30
5.4 Outputs.....	31
5.4.1 Pump	31
5.4.2 Alarm.....	31
5.5 Audible Indicators	31
6. TROUBLE SHOOTING.....	32
7. MAINTENANCE	33
7.1 Cleaning	33
8. PUMP INFORMATION.....	34
8.1 Drive.....	34
8.2 Suction Lift.....	34
8.3 Rotation	34
NOTES.....	37
APPENDIX A – REFERENCE CHARTS	38

Conventions

For the remainder of this bulletin, the following Conventions are in effect.



A WARNING DEFINES A CONDITION THAT COULD CAUSE DAMAGE TO BOTH THE EQUIPMENT AND THE PERSONNEL OPERATING IT. PAY CLOSE ATTENTION TO ANY WARNING.



Notes are general information meant to make operating the equipment easier.



Tips have been included within this bulletin to help the operator run the equipment in the most efficient manner possible. These “Tips” are drawn from the knowledge and experience of our staff engineers, and input from the field.



This is a procedure heading. A Procedure Heading indicates the starting point for a procedure within a specific section of this manual.

1. Introduction

The Digital Glycol Feeder (DGF), is designed to make-up for lost glycol in a closed loop system. It accomplishes this by monitoring system pressure. When system pressure drops below a set pressure (indicating glycol loss), the pump activates and restores the lost glycol, bringing the system pressure back to the proper operating level.

Model DGF1 includes a control unit in a NEMA Type 4 enclosure, a 55 gallon polyethylene tank, a level wand, a pressure switch and a positive displacement pump for controlling glycol feed in a single loop system. The feeder is mounted on a welded stand for ease in shipment and installation.

Model DGF2 controls a dual loop system.

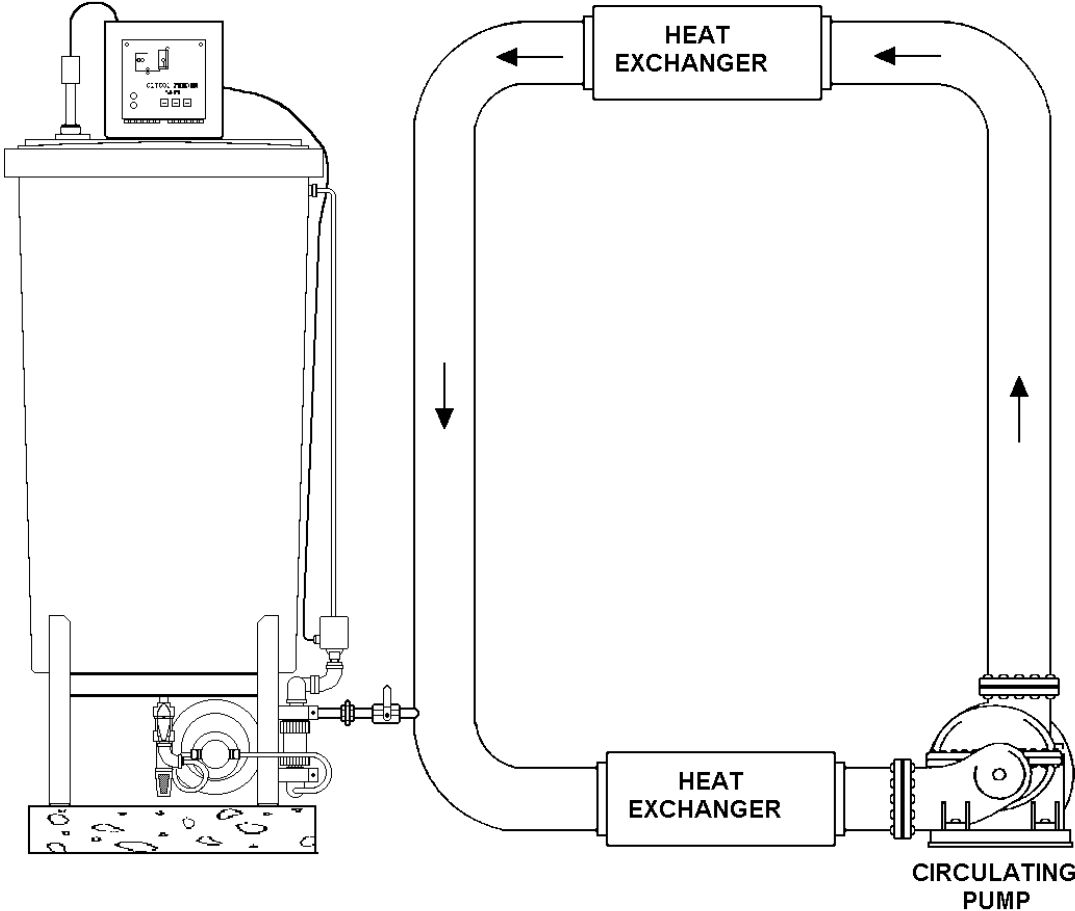

Figure 1 – Typical Installation

1.1 Systems and Options

The Glycol Feeder for Closed Loop Systems includes:

- control unit in a NEMA type 4X enclosure
- 55 gallon polyethylene tank and stand

Refer to *Figure 2 – Options List*, for Glycol Feeder options.

DIGITAL GLYCOL FEEDER		DGF	—	—	—	—	—	—	—																																																		
CLOSED LOOPS	1 = SINGLE LOOP 2 = DUAL LOOP																																																										
CONDUIT PREWIRE	A = CONDUIT B = PREWIRE (NOT AVAILABLE WITH 230V UNITS)																																																										
AUDIBLE ALARM	A = WITHOUT AUDIBLE ALARM B = WITH AUDIBLE ALARM																																																										
ALARM OUTPUT OPTION	X = NONE A = DRY CONTACT, SINGLE B = DRY CONTACT, DUAL C = AC OUTPUT, SINGLE D = AC OUTPUT, DUAL E = DRY CONTACT, SINGLE & AC OUTPUT, SINGLE																																																										
PRESSURE SWITCH OPTION	A = STD PRESSURE SWITCH B = LOW PRESSURE SWITCH C = (1) STD. (1) LOW PRESSURE SWITCH (DGF2 ONLY)																																																										
PUMP AND VOLTAGE RATING	<table border="0"> <tr> <td>A = 115V NO PUMP</td> <td></td> <td></td> <td></td> <td></td> <td></td> <td></td> <td></td> <td></td> <td></td> </tr> <tr> <td>B = 230V NO PUMP</td> <td></td> <td></td> <td></td> <td></td> <td>MUST BE CONDUIT</td> <td></td> <td></td> <td></td> <td></td> </tr> <tr> <td>C = 115V 60 Hz 1.5GPM @ 100 PSI</td> <td></td> <td></td> <td></td> <td></td> <td></td> <td></td> <td></td> <td>G2-P1</td> <td></td> </tr> <tr> <td>D = 230V 60 Hz 1.5GPM @ 100 PSI</td> <td></td> <td></td> <td></td> <td></td> <td>MUST BE CONDUIT</td> <td></td> <td></td> <td>G2-P1</td> <td></td> </tr> <tr> <td>G = 230V 50 Hz 1.25GPM @ 100 PSI ("CE")</td> <td></td> <td></td> <td></td> <td></td> <td>MUST BE CONDUIT</td> <td></td> <td></td> <td>G2-P1</td> <td></td> </tr> </table>									A = 115V NO PUMP										B = 230V NO PUMP					MUST BE CONDUIT					C = 115V 60 Hz 1.5GPM @ 100 PSI								G2-P1		D = 230V 60 Hz 1.5GPM @ 100 PSI					MUST BE CONDUIT			G2-P1		G = 230V 50 Hz 1.25GPM @ 100 PSI ("CE")					MUST BE CONDUIT			G2-P1	
A = 115V NO PUMP																																																											
B = 230V NO PUMP					MUST BE CONDUIT																																																						
C = 115V 60 Hz 1.5GPM @ 100 PSI								G2-P1																																																			
D = 230V 60 Hz 1.5GPM @ 100 PSI					MUST BE CONDUIT			G2-P1																																																			
G = 230V 50 Hz 1.25GPM @ 100 PSI ("CE")					MUST BE CONDUIT			G2-P1																																																			
AGENCY APPROVALS	X = NONE A = ETL (USA & CANADA) (PENDING) B = CE (PENDING)																																																										
UNASSEMBLED ASSEMBLED	A = UNASSEMBLED B = ASSEMBLED (NOTE: MUST SHIP FREIGHT)																																																										

Figure 2 – Options List

2. Installation

2.1 Assembly



If your DGF is shipped to you unassembled, perform the following: (If you ordered the assembled version go to section 2.2 – Electrical Wiring.)



FAILURE TO FOLLOW THESE WARNINGS AND ASSEMBLY INSTRUCTIONS COULD RESULT IN SERIOUS INJURY OR DEATH!

- Read all instructions carefully before assembly.
- Check all connections to ensure they are tight before applying pressure to the system.
- Wire in accordance to applicable electrical codes.
- Never subject components to full water immersion.
- Never attempt to move this system when the tank is full.
- **DO NOT** apply lateral force to the tank. The tank can tip spilling the contents.
- When filling the tank use care to prevent spillage or splashing on the wiring or tank cover.
- This system is designed for feeding Ethylene Glycol into pressurized closed loop systems.
- **DO NOT** run pumps dry.
- **DO NOT** exceed rated pressure of 80 psi.



DO NOT DEVIATE FROM THESE ASSEMBLY INSTRUCTIONS. QUALIFIED CUSTOMER SERVICE REPRESENTATIVES CAN BE REACHED AT THIS TOLL FREE NUMBER IF ASSISTANCE IS NEEDED: 1 (800) 333-6677.

2.1.1 Tools Required For Assembly

- Phillips head screw driver.
- Adjustable wrench.

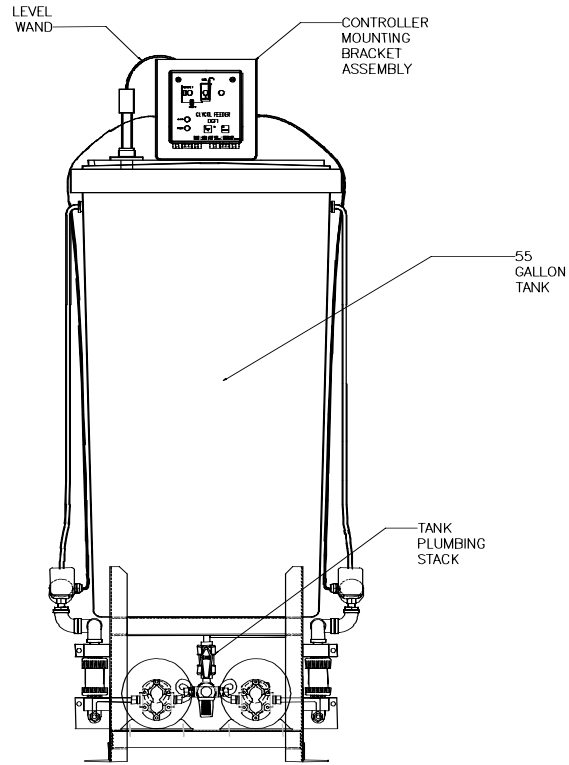

FRONT VIEW

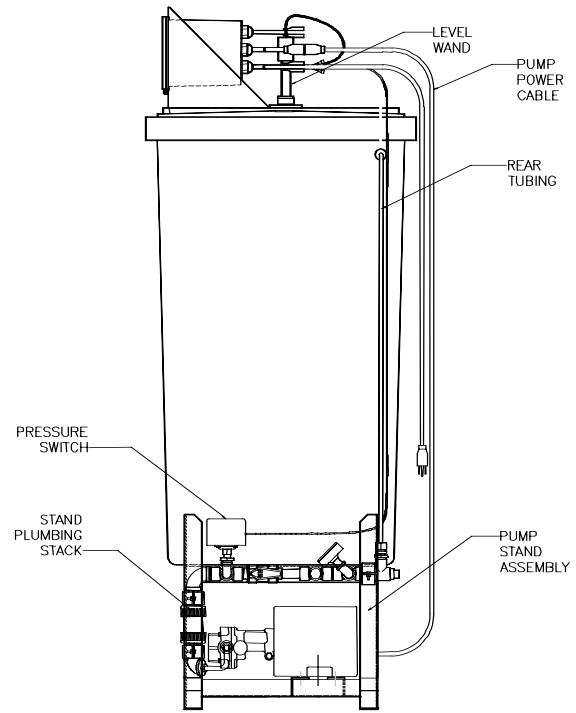

SIDE VIEW

Figure 3 – Glycol Feeder Assembly

2.1.2 Pre-Assembly

1. Unpack all cartons and inspect for damage. If shipping damage is found, save all packaging and notify the carrier immediately. Lay out and identify all parts.

Parts List:

Item 1: Tank Plumbing Stack.

Item 2: Controller mounted on a bracket with two-cover mounting screws attached.

Item 3: Package of Cable Ties & Cable Tie Holders.

Item 4: Pump/Stand assembly including stand, pump(s) with tubing attached to both the suction and discharge sides, stand plumbing assembly(s), pressure switch cable (attached to switch) and re-circulation tubing (attached to the pressure relief valve on the back end of the stand plumbing stack).

Item 5: Tank with plumbing stack adapter attached.

Item 6: Tank cover with two controller mounting screws attached.

Item 7: Level Wand

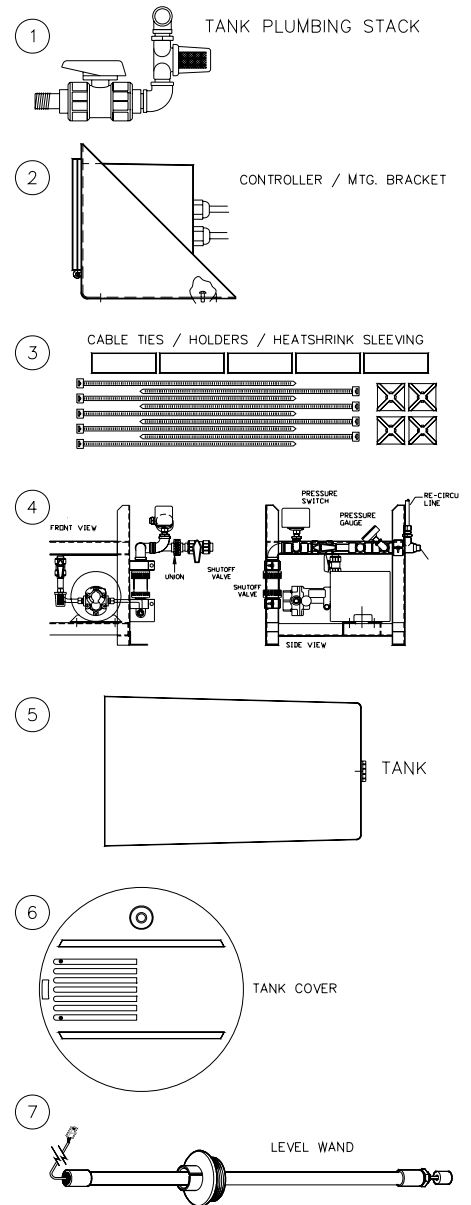

Figure 4 – Parts ListLocation

1. Locate a space approximately 3' x 3' that is convenient to system piping and to an electrical outlet or power source.
2. Place the tank stand in the installation location with the front (pump head/wet end side) facing out.



THE ASSEMBLY IS VERY HEAVY AND HELP MAY BE REQUIRED. DO NOT LIFT THE STAND BY THE PLUMBING STACK(S). LIFT THE UNIT BY THE METAL FRAME OF THE STAND ASSEMBLY. USE GLOVES AS THE STAND MAY HAVE SHARP EDGES.

2.1.3 Plumbing

1. Attach the plumbing stack on the side of the stand to the closed loop system using a union and shut off valve (not supplied).

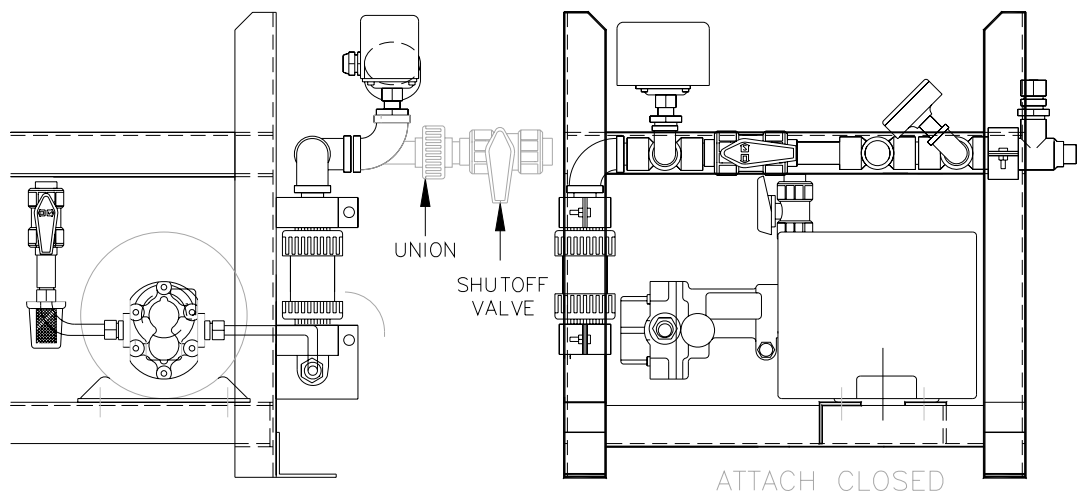
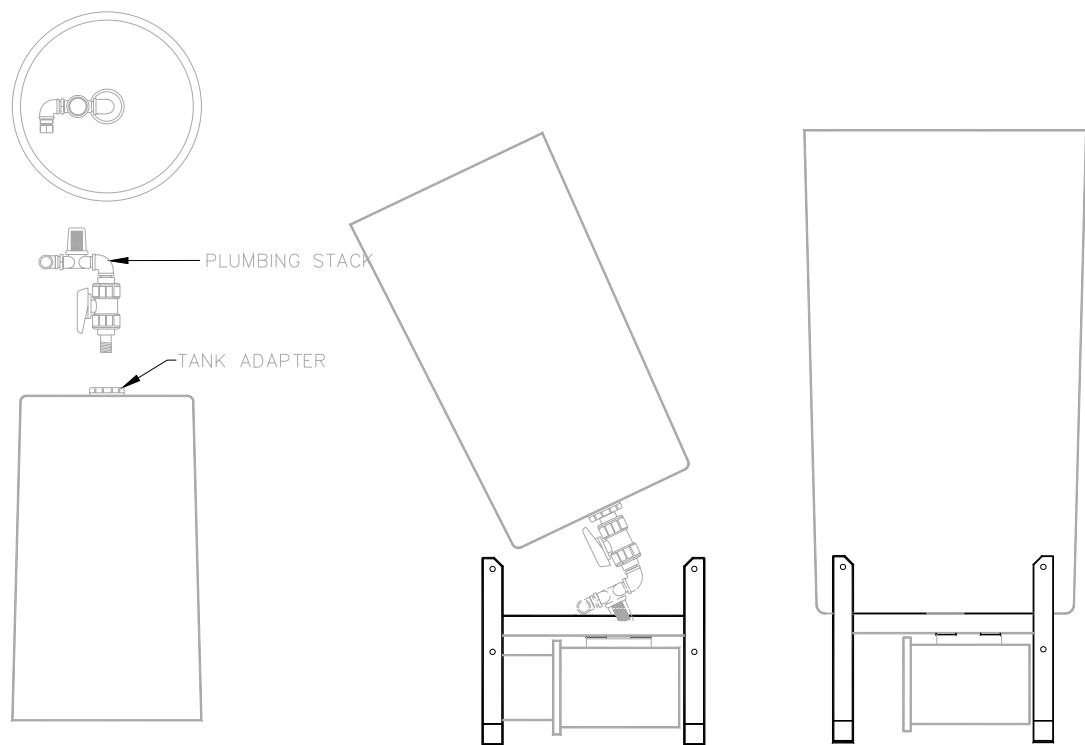

Figure 5 – Closed Loop Connection

2.1.4 Mounting The Tank

1. Turn the tank upside down and screw the plumbing stack assembly into the adapter attached to the bottom of the tank. Tighten until snug plus 1/4 turn. Orient as shown in *Figure 6 – Tank Installation* below.
2. Lift the tank, turning the open side up with the plumbing stack against your body.
3. Tip the top of the tank toward you and lower the tank onto the stand while feeding the plumbing stack through the pump support and under the front cross bar between the pumps.

Figure 6 – Tank Installation



2.1.5

Mounting The Controller

1. Loosen the screws mounted to the back of the controller mounting bracket. **DO NOT REMOVE!**
2. Set the controller on the tank cover so that the holes in the front of the controller bracket slide over the two screws mounted to the top of the tank cover.
3. Slide the bracket assembly towards the front of the unit so that the bracket fits under the screw head while aligning the rear bracket screws with the pre-drilled holes in the tank cover and secure the rear screws.
4. Tighten the front screws.
5. Place the tank cover on the top of the tank so the controller is facing the front (wet) end of the pump(s).

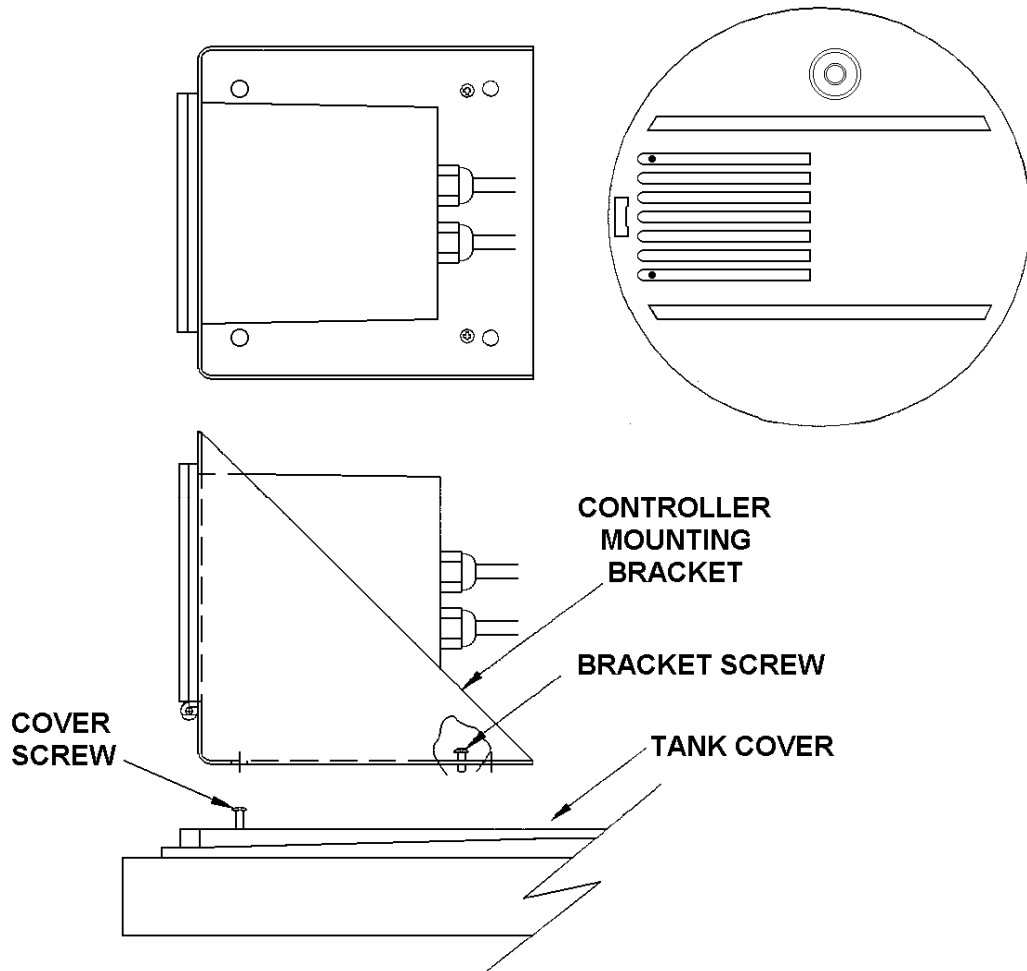
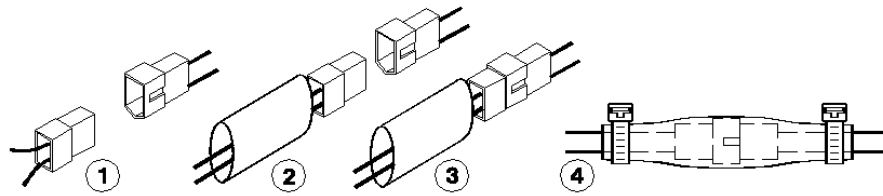

Figure 7 – Controller Installation

Refer to the Molex/Heat shrink sleeving procedure shown below while making the connections outlined in sections 2.1.7, and 2.1.8.



- 1 Find Mating Connections.
- 2 Slide heat shrink sleeving over one of the connectors.
- 3 Assemble the connectors together.
- 4 Slide heat shrink over connection. Shrink sleeving and secure each end with a cable tie as shown.

2.1.6 Installing The Level Wand

1. Insert the Level Wand in the hole provided in the tank cover.
2. Adjust the height of the wand to the alarm level required by loosening the adjustment lock nut and sliding the wand through the adapter.
3. Tighten the adjustment lock nut.
4. Connect the level wand cable to the three position cable on the back of the controller, marked “LEVEL WAND”.

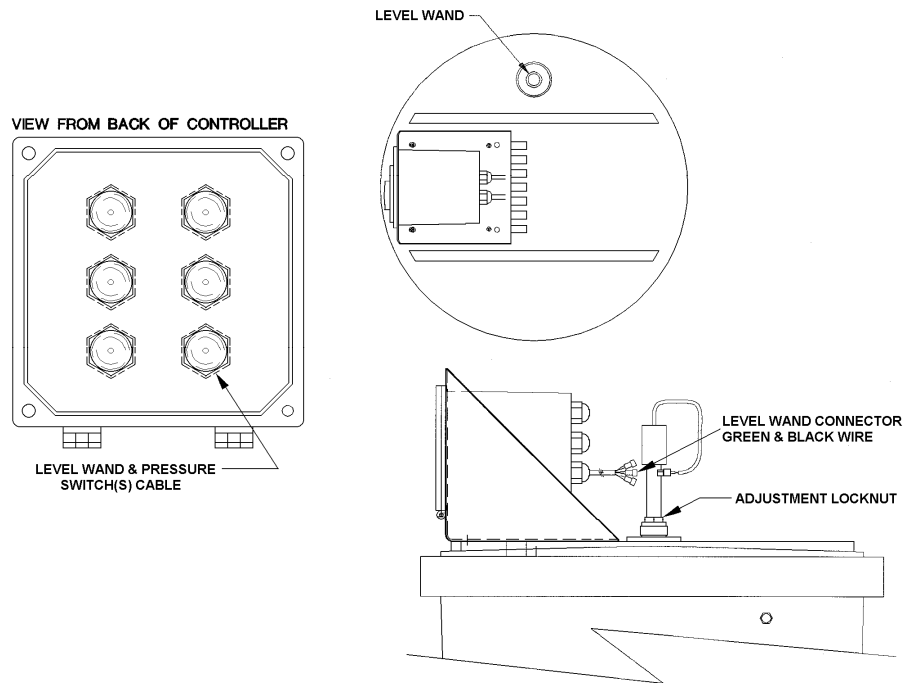

Figure 8 – Level Wand Installation

2.1.7 Connecting The Pressure Switch

1. Connect the cable from the pressure switch to the three position cable on the back of the controller marked “PRESSURE SWITCH #1”.

Repeat steps 2.1.8, 2.1.9, and 2.1.10 if you have a dual loop system. The second switch is connected to the cable marked “PRESSURE SWITCH #2”.

2.1.8 Connecting The Pump

1. Connect the loose end of the tubing attached to the pump to the fitting on the plumbing stack on the bottom of the tank.
 - a) Insert the tubing approximately 1/2” into the fitting.
2. Using an adjustable wrench, tighten the fitting until snug. DO NOT over tighten. Fittings should be hand tight plus 1/4 turn. (If you have a dual pump system, repeat this step for the second pump.)

2.1.9 Connecting The Re-Circulation Line

1. Connect the loose end of the tubing attached to the pressure relief valve on the back end of the plumbing stack (attached to the side of the stand) to the fitting on the side of the tank.
 - a) Insert the tubing approximately 1/2” into the fitting.
2. Using an adjustable wrench, tighten the fitting until snug. DO NOT over tighten. Fittings should be hand tight plus 1/4 turn. (If you have a dual pump system, repeat this step for the second pump.)



Refer to *Figure 9 – Primary Connections* on the next page as you are performing steps 2.1.8, 2.1.9, and 2.1.10.

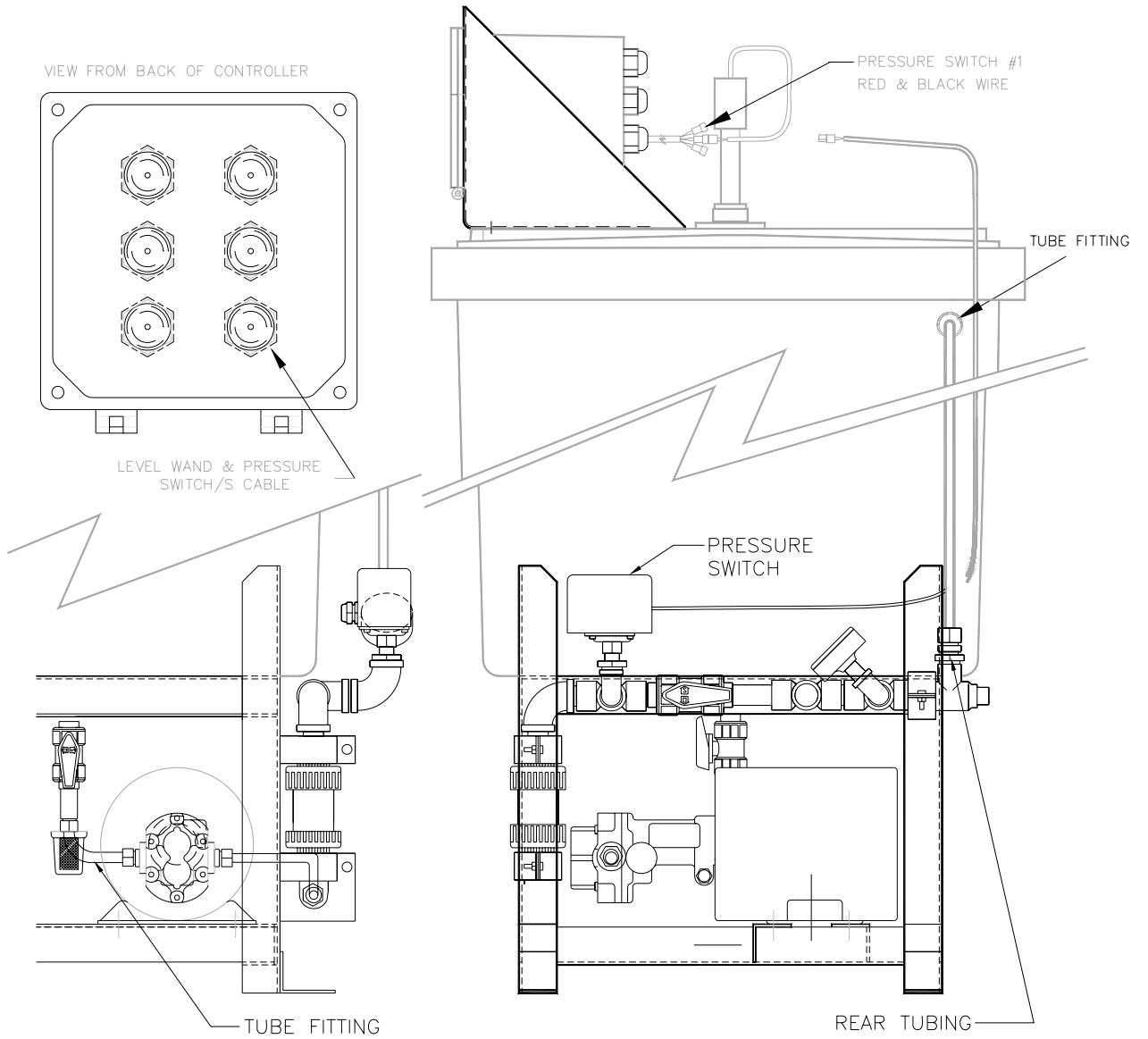

Figure 9 – Primary Connections

2.2 Electrical Wiring

The procedure you will use to make the electrical connections is dependent on the option package you select (refer to *Figure 2 – Options List*).

2.2.1 115VAC Pre-Wired Unit Connections

2.2.1.1 Dual AC Alarm Connection

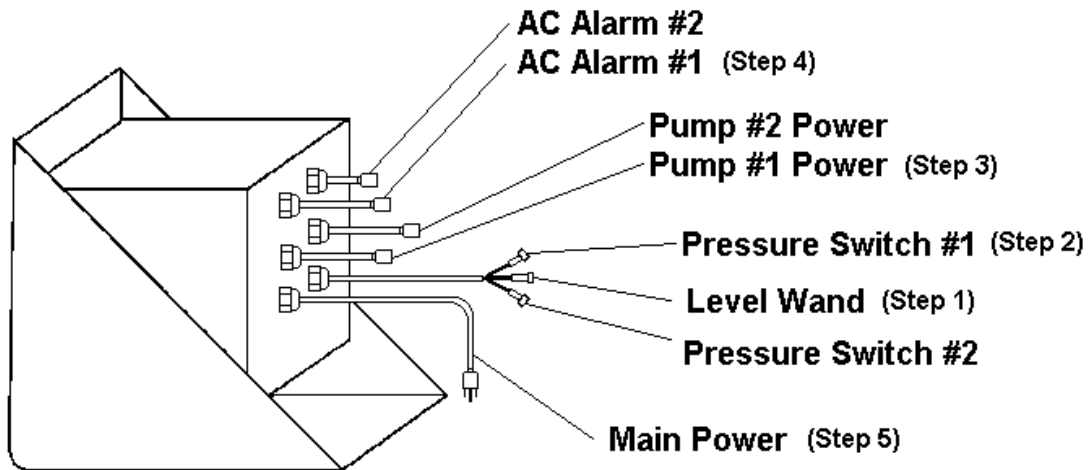

Figure 10 – Dual AC Alarm Connection

1. Plug the 2-wire Molex connector tagged Level Wand into its mate on the end of the PVC wand (low liquid level switch).
2. Plug the 2-wire Molex connector tagged Pressure Switch #1 into its mate on the pressure switch attached to the closed loop system.
3. Plug the pump into the Pump #1 Power receptacle (pigtail).
4. Plug the Alarm Indicators (e.g.: warning light) into the associated AC Alarm (#1 & #2) receptacles (power pigtail).
5. Plug in the **Main Power** cord.



NOTE

For the purpose of this manual, the DGF1 is used as the example. If you have a DGF2 repeat steps 2 and 3 for the second pressure switch and pump.

2.2.1.2 Dual Dry Contact Connection

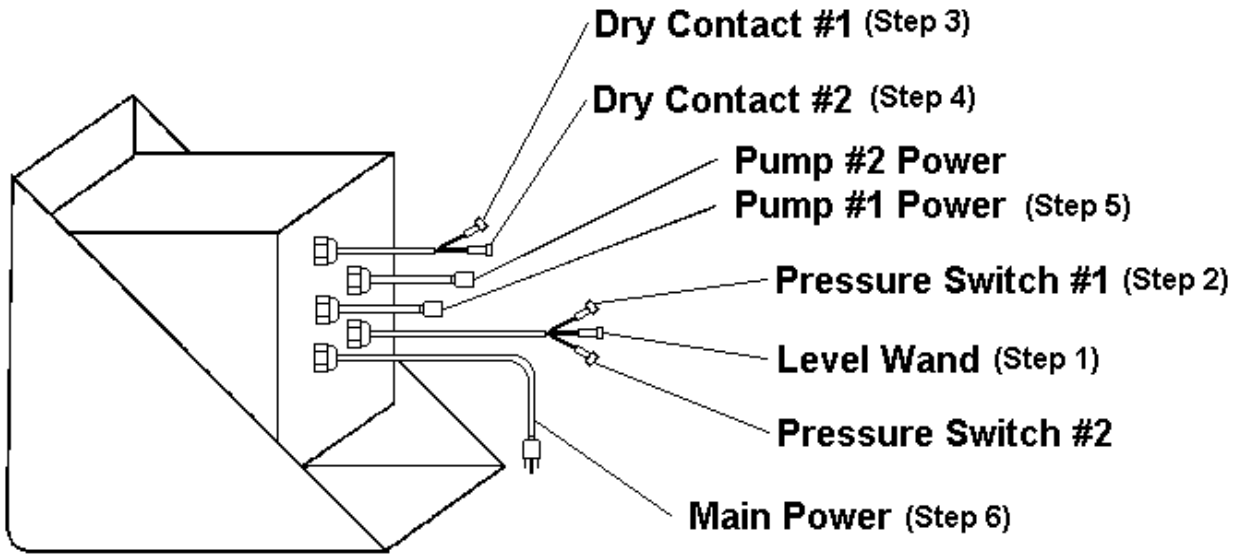

Figure 11 – Dual Dry Contact Connection

1. Plug the 2-wire Molex connector tagged Level Wand into its mate on the end of the PVC wand (low liquid level switch).
2. Plug the 2-wire Molex connector tagged Pressure Switch #1 into its mate on the end of the associated pressure switch attached to the closed loop system.
3. Plug the 2-wire Molex connector tagged Dry Contact #1 into a device capable of receiving a dry-contact input (e.g., PLC, PULSATROL PLUS LEVEL INPUT, etc.)
4. Plug the 2-wire Molex connector tagged Dry Contact #2 into a device capable of receiving a dry-contact input (e.g., PLC, PULSATROL PLUS LEVEL INPUT, etc.)
5. Plug the pump into the Pump #1 Power receptacle (pigtail).
6. Plug in the **Main Power** cord.



NOTE

For the purpose of this manual, the DGF1 is used as the example. If you have a DGF2 repeat steps 2 and 5 for the second pressure switch and pump.

2.2.1.3 Dry Contact – AC Alarm Connection

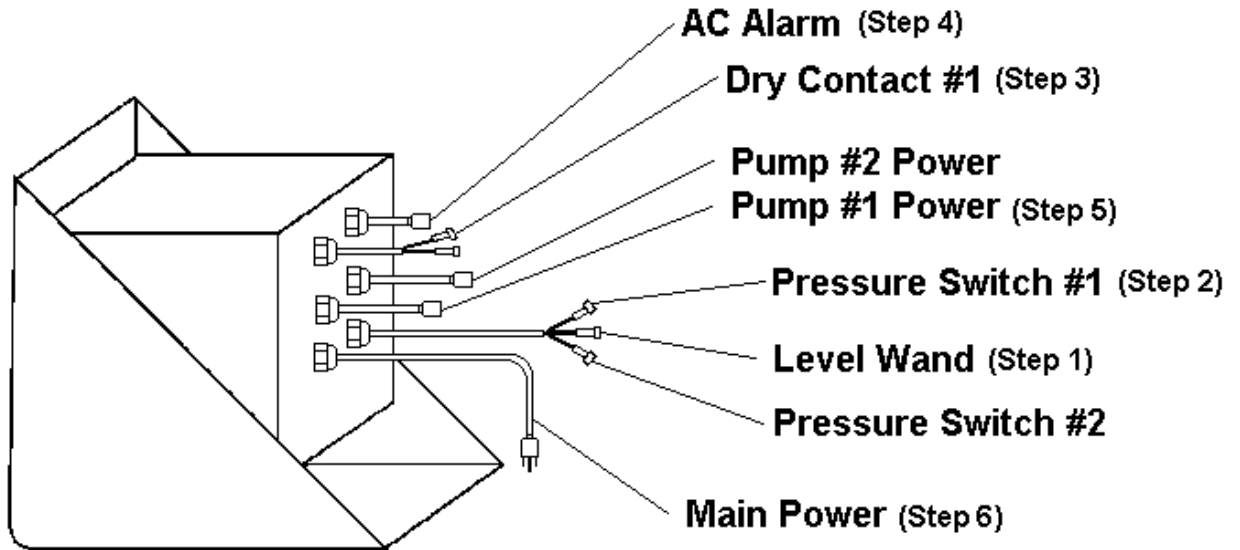

Figure 12 – Dry Contact – AC Alarm Connection

1. Plug the 2-wire Molex connector tagged Level Wand into its mate on the end of the PVC wand (low liquid level switch).
2. Plug the 2-wire Molex connector tagged Pressure Switch #1 into its mate on the associated pressure switch attached to the closed loop system.
3. Plug the 2-wire Molex connector tagged Dry Contact #1 into a device capable of receiving a dry-contact input (e.g., PLC, PULSATROL PLUS LEVEL INPUT, etc.).
4. Plug the Alarm Indicator (e.g.: warning light) into the associated AC Alarm receptacle (power pigtail).
5. Plug the pump into the Pump #1 Power receptacle (pigtail).
6. Plug in the **Main Power** cord.



For the purpose of this manual, the DGF1 is used as the example. If you have a DGF2 there are connections for the second pressure switch, and pump (steps 2, & 5).

2.2.2 115VAC/230VAC Conduit Connections

If your application requires 230VAC, or you did not order the 115VAC unit pre-wired, you will hard wire the electrical connections as shown in the following paragraphs (refer to *Figure 13 – Main Circuit Board* below for terminal locations).

2.2.2.1 Getting Around The Main Circuit Board

The Main Circuit board shown below (*Figure 13 – Main Circuit Board*) has all the possible connection points shown. Remember that the main circuit board installed in your DGF will include only the connection points for the options you ordered.

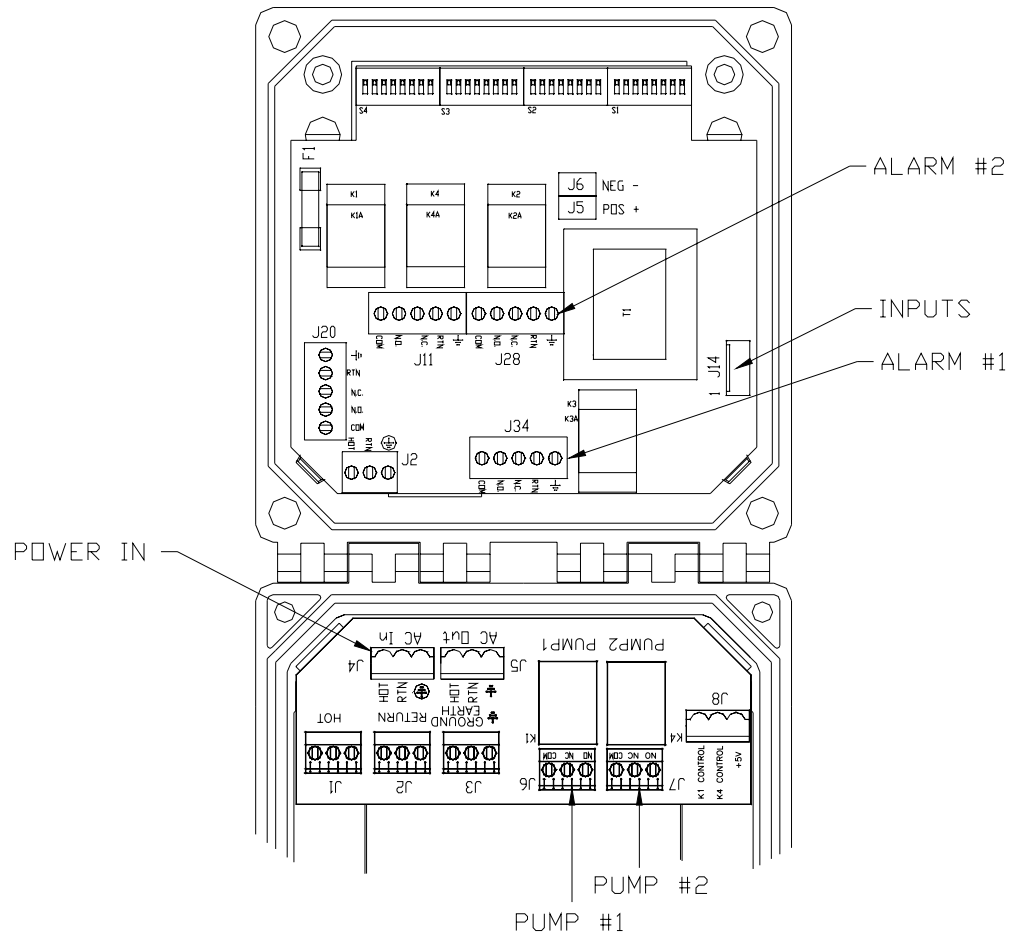

Figure 13 – Main Circuit Board

Complete the electrical wiring of your DGF following the steps defined below, in the order specified. For a proper setup, do not skip or modify any steps.



Install the unit according to IEC 1010 Clause 6, and to local wiring code(s).

2.2.2.1.1 DGF Inputs (J14)

The inputs to the DGF are pre-wired at the factory and are connected to main circuit board at J14, via a pre-wired harness with Molex connectors.

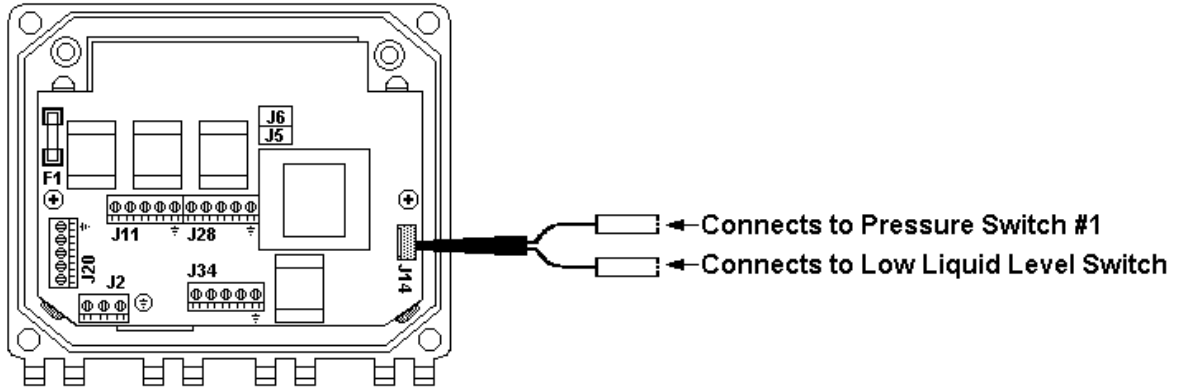

Figure 14 – DGF Inputs

1. Plug the 2-wire Molex connector tagged Level Wand into its mate on the end of the PVC wand (low liquid level switch).
2. Plug the 2-wire Molex connector tagged Pressure Switch #1 into its mate on the pressure switch attached to the closed loop system.



For the purpose of this manual, the DGF1 is used as the example. If you have a DGF2 there is a connection for the second pressure switch on the same cable as the first switch.

2.2.2.1.2 Dry Contact #1 Or AC Output #1

1. The **Dry Contact #1** connection is made to J34 pins 1, 2 or 3.
or
2. The **AC Output #1** connection is made to J34 pins 2 or 3, 4, & 5.
(The N.O. lead was used in the example below.)

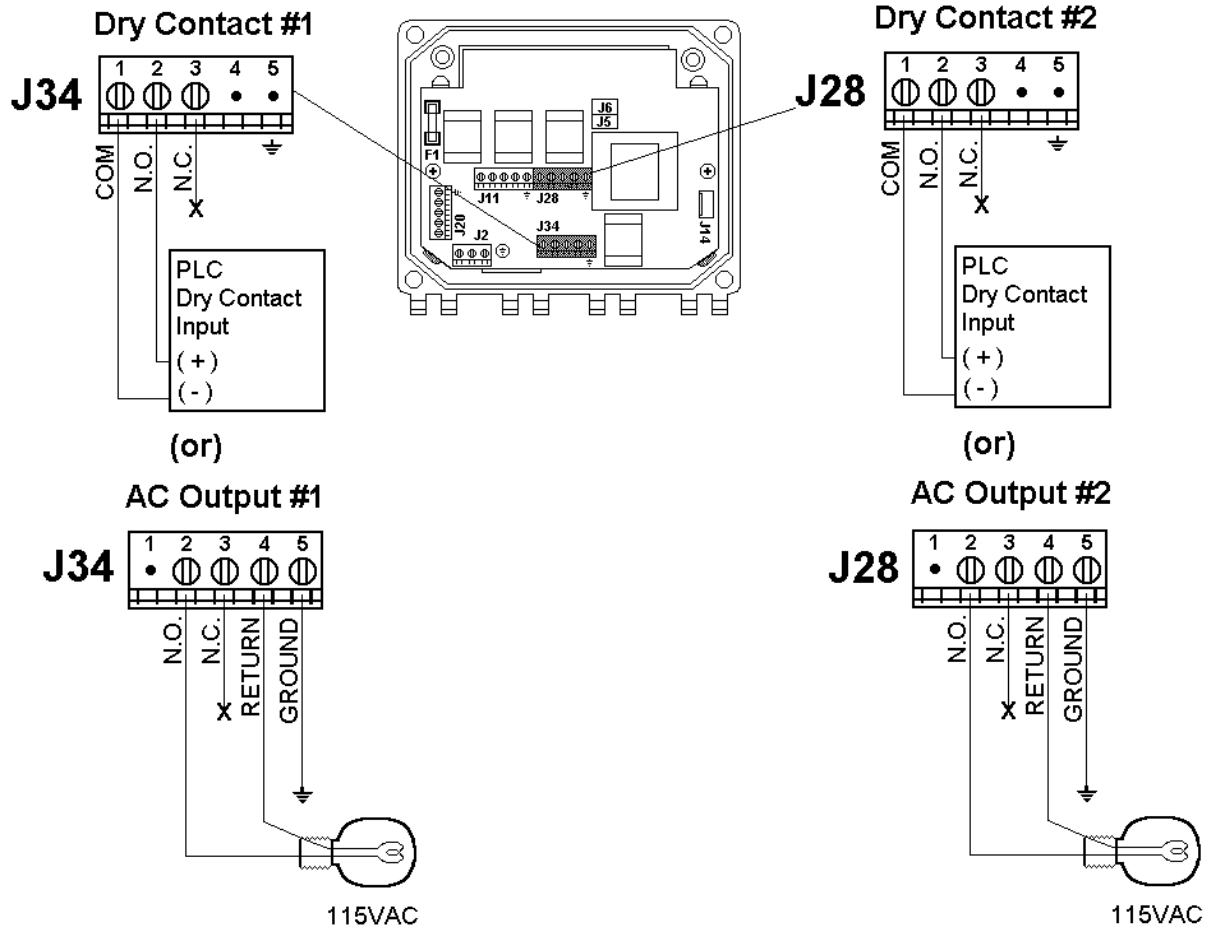

Figure 15 – Dry Contact & AC Output connections



If you order your DGF with one Dry Contact output and one AC Output, you will always connect the Dry Contact output to J34, and connect the AC Output to J28.

2.2.2.1.3 Connecting The Pump(s)

1. If you have a single pump system, connect Pump #1 to J2-3, J3-3 & J6-3 as shown in *Figure 16 – Pump Wiring Connections*. This connection will allow the pump to energize when the corresponding pressure switch trips. If you have a dual pump system, connect pump #2 to J2-1, J3-1 & J7-3 as shown below.

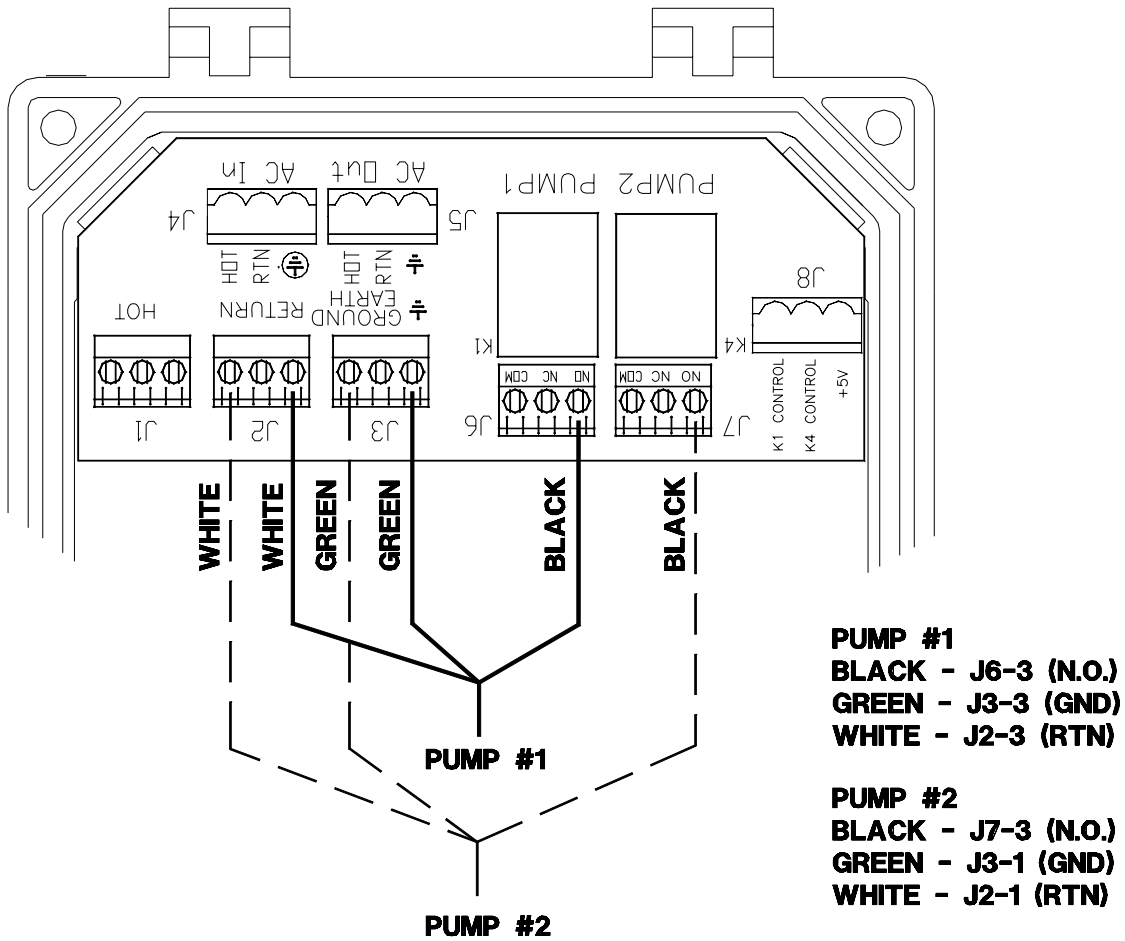

Figure 16 – Pump Wiring Connections

2.2.2.1.4 Connecting The Audible Alarm

1. Connect the Audible Alarm by connecting the alarm's Red wire to J5 and the alarm's Black wire to J6.

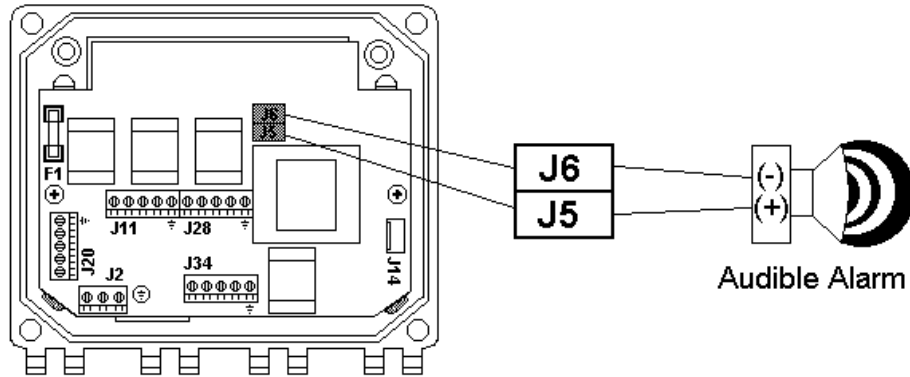

Figure 17 – Audible Alarm Hook up



This connection will be made at the factory when the option is selected.

2.2.2.1.5 Connecting main power (“Non-CE” approved)

1. Connect the main power to J4 pins 1, 2, & 3 as shown in *Figure 18 – Main Power Connections* below.

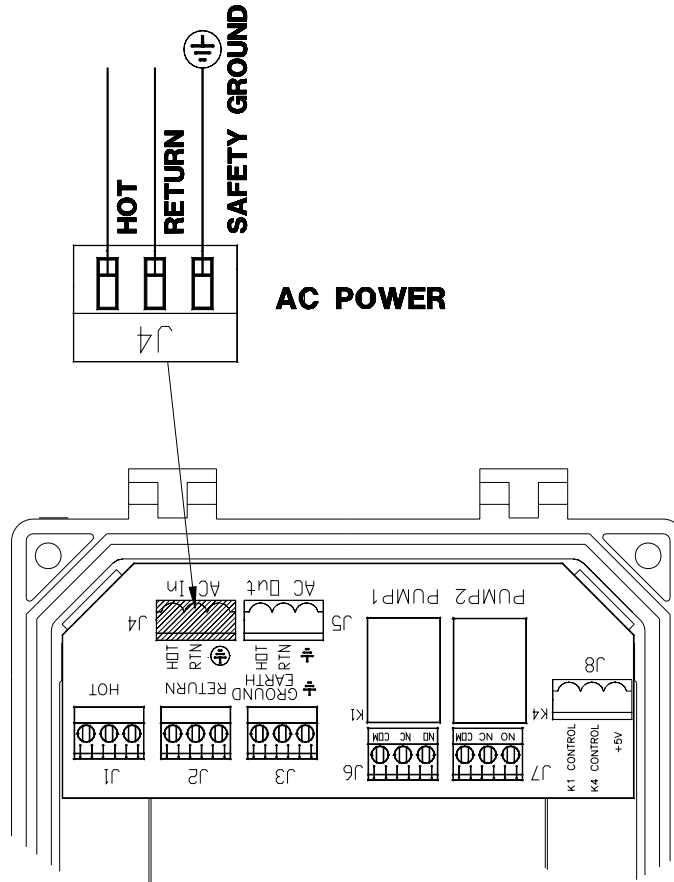

Figure 18 – Main Power Connections (Non-CE) Approved



THE SUPPLIED AC POWER VOLTAGE MUST MATCH THE MARKED VOLTAGE RATING (POSITION 6 IN THE OPTIONS LIST).

2.2.2.1.6 Connecting main power (“CE” approved)

1. Connect the main power to the line filter using the wire nuts that were provided with your Digital Glycol Feeder as shown in *Figure 19, Main Power Connections (CE) Approved* below:
 - a) Brown = Hot
 - b) Blue = Return
 - c) Green/Yellow = Ground

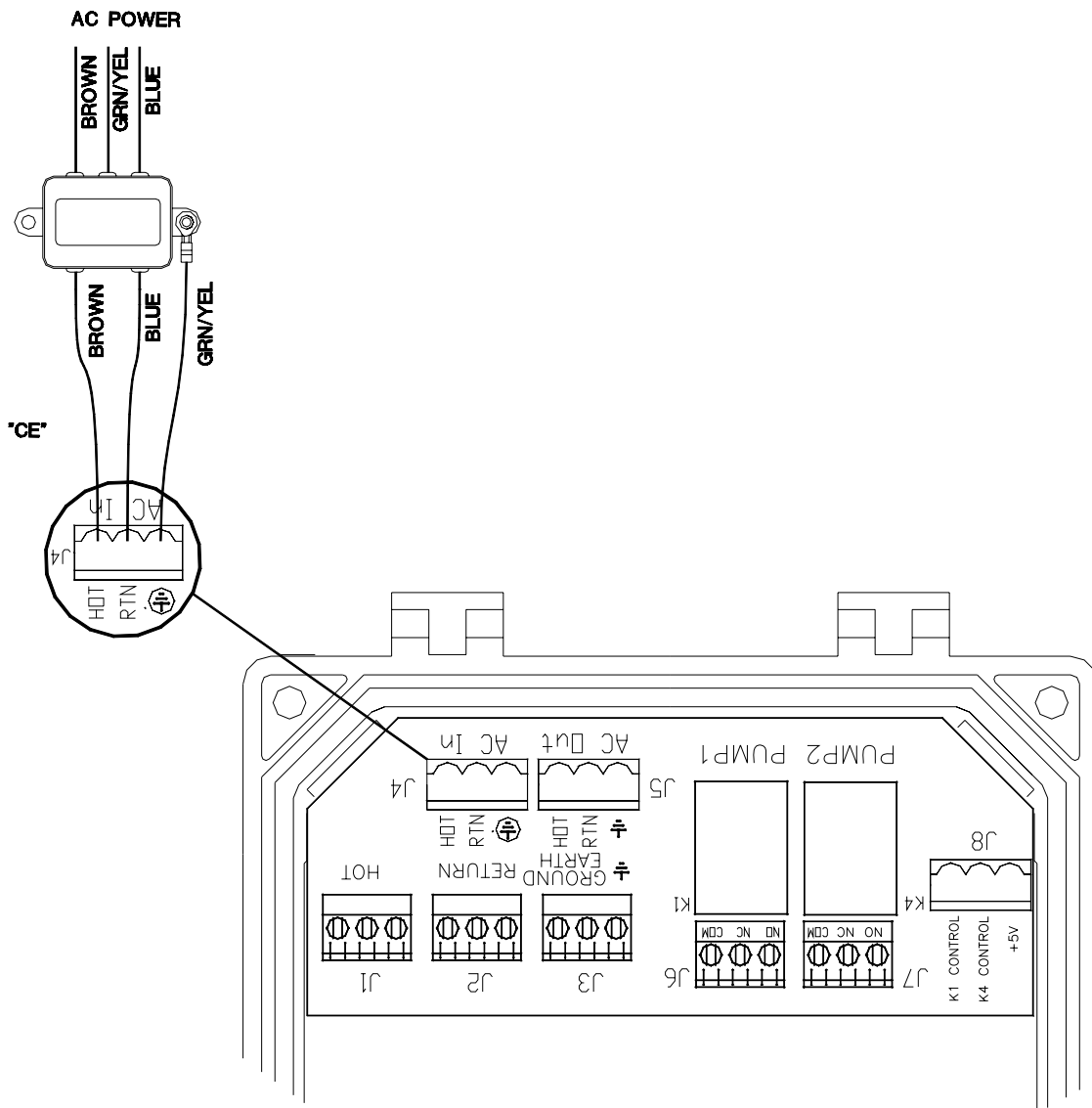

Figure 19 – Main Power Connections (CE) Approved

2. The wires from the line filter to J4, pins 1, 2, & 3 will be connected at the factory.

Connection of:	Terminal Block		Lead Color	
			U.S.	International
Inputs	J14		Multiple	Multiple
Dry Contact #1 (Alarm Option)	J34-1	COM	Red	Red
	J34-2	N.O.	Black	Black
	J34-3	N.C.	Black	Black
Dry Contact #2 (Alarm Option)	J28-1	COM	White	White
	J28-2	N.O.	Black	Black
	J28-3	N.C.	Black	Black
AC Output #1 (Alarm Option)	J34-2	N.O.	Black	Brown
	J34-3	N.C.	Black	Brown
	J34-4	Return	White	Blue
	J34-5	Ground	Green	Green/Yellow Stripe
AC Output #2 (Alarm Option)	J28-2	N.O.	Black	Brown
	J28-3	N.C.	Black	Brown
	J28-4	Return	White	Blue
	J28-5	Ground	Green	Green/Yellow Stripe
Pump #1	J6-3	N.O.	Black	Brown
	J2-3	Return	White	Blue
	J3-3	Ground	Green	Green/Yellow Stripe
Pump #2	J7-3	N.O.	Black	Brown
	J2-1	Return	White	Blue
	J3-1	Ground	Green	Green/Yellow Stripe
Audible Alarm +	J5		Red	Red
Audible Alarm –	J6		Black	Black
Power Cord or Conduit Wiring “Non-CE “ Units	J4-1	Hot	Black	Brown
	J4-2	Return	White	Blue
	J4-3	Ground	Green	Green/Yellow Stripe
Power Cord or Conduit Wiring “CE “ Units	Line Filter	Hot	N/A	Brown
	Line Filter	Return	N/A	Blue
	Line Filter	Ground	N/A	Green/Yellow Stripe

3. Glycol Feeder System

3.1 User Interface

The User Interface is shown below (Figure 20).

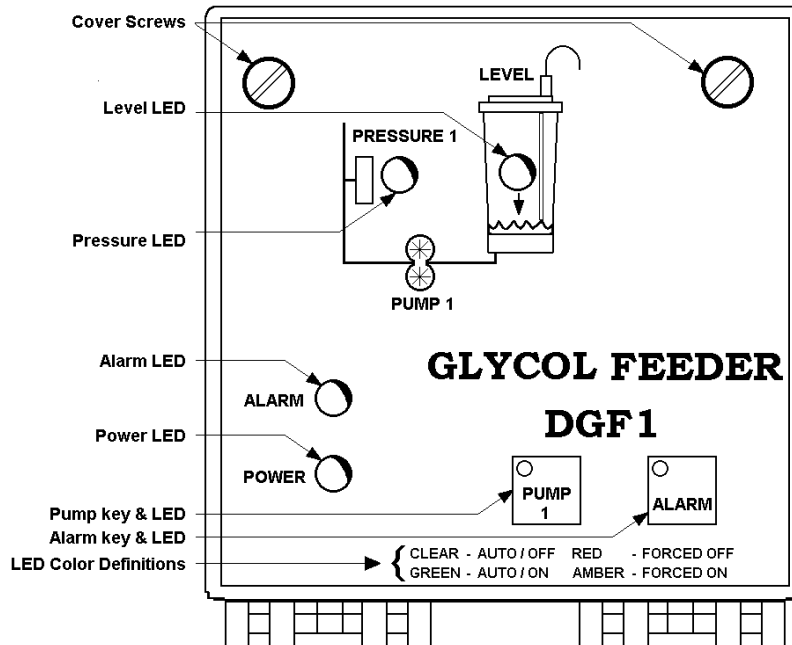

Figure 20 – User Interface

The User Interface consists of the following:

- Pump key (AUTO, FORCED ON, FORCED OFF)
- Alarm key (AUTO, FORCED ON, FORCED OFF)
- Power LED – GREEN (Power On = LED On)
- Alarm LED – RED (Alarm On = LED On)
- Pressure LED (Low Pressure = RED)
- Level LED (Low Level = RED)

The Pump key and Alarm key have an LED installed in the upper left corner of the key. The color of the LED indicates the status of the Control Relay. Both the Pump and Alarm keys use the same color coding.

- CLEAR – Auto-OFF
- GREEN – Auto-ON
- RED – Forced-OFF
- AMBER – Forced-ON



In this section the DGF1 controller/user interface was used as a reference. The DGF2 controller/user interface is similar in design, but has an additional pump key (PUMP 2) and an additional pressure LED (PRESSURE 2).



If a relay is in the **FORCED OFF** mode and power is lost, the relay will still be in the **FORCED OFF** state when the unit is powered up again.

3.2 Start Up & Calibration

This section defines the procedure for starting your Digital Glycol Feeder for the first time.

1. Make all plumbing and electrical connections.
2. Fill the tank with glycol to a level adequate to turn off the low level alarm.



The pump is locked out in the automatic mode when the low level alarm is ON.

- a) Filling the tank

Determine a percent by mixing water proportionally to a glycol solution.

		Glycol	H ₂ O
20%	Glycol Solution	2"	8"
30%	Glycol Solution	3"	7"
40%	Glycol Solution	4"	6"
50%	Glycol Solution	5"	5"
60%	Glycol Solution	6"	4"
70%	Glycol Solution	7"	3"
80%	Glycol Solution	8"	2"

3. Check for leaks.
4. Plug in the control box.



THE PRESSURE RELIEF VALVE IS FACTORY SET AT 50PSI. DO NOT OPERATE THE DIGITAL GLYCOL FEEDER ABOVE 100PSI. IF YOUR APPLICATION REQUIRES A HIGHER OPERATING PRESSURE, CONSULT THE FACTORY.

5. Force the pump(s) off by pressing the [PUMP] key once. (LED will be RED.)
6. Remove the Pressure Switch cap (refer to *Figure 21*) to make pressure switch adjustments.



The initial setting of the pressure switch is critical to the proper operation of the Digital Glycol Feeder. The pressure gauge on the manifold system allows you to see the operating pressure.

7. Pressurize the Glycol Feeder system by opening the Main Shutoff valve.

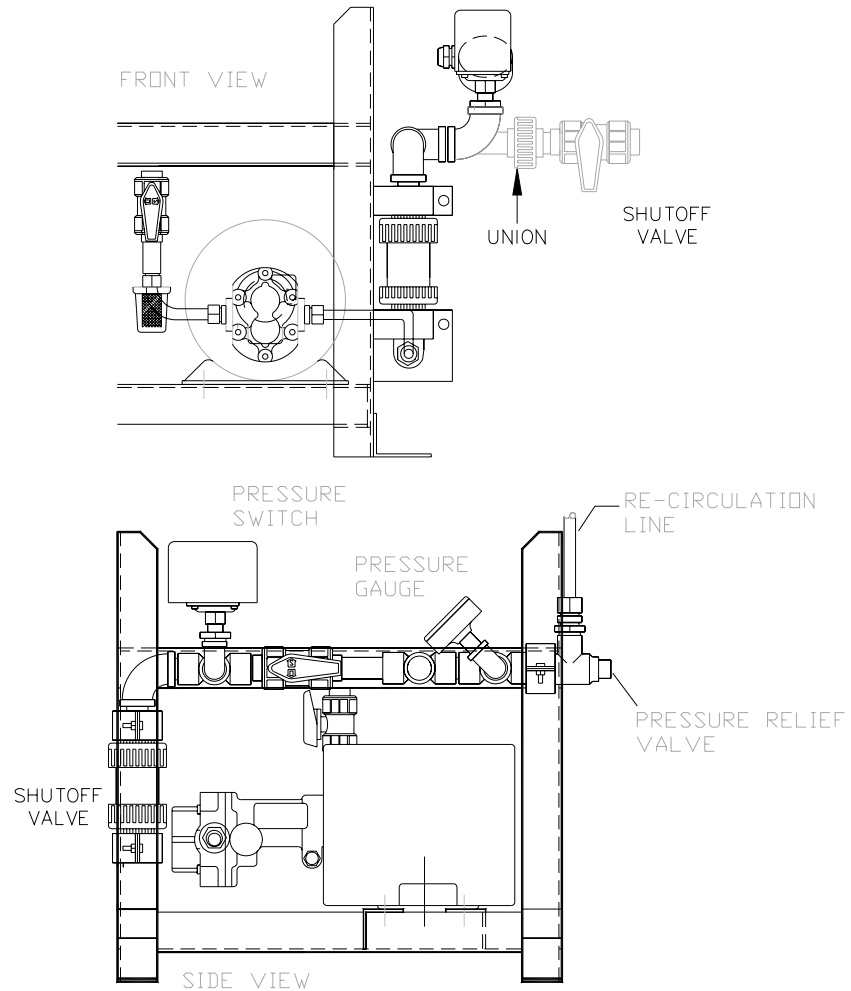

Figure 21 – Start-up Component Location

8. Observe the Pressure LED.
 - a) If the LED is RED, adjust the Pressure Switch Range Adjustment Screw (refer to *Figure 22*) counter-clockwise until the Pressure LED goes out (refer to *Figure 20*).
or
 - b) If the LED is out, adjust the Pressure Switch Range Adjustment Screw clockwise until the LED is RED. Then turn the Pressure Switch Range Adjustment Screw in a counter-clockwise direction until the LED goes out.
9. Test your setting by:
 - a) Close the Main Shutoff valve that you opened in step 7.
 - b) Note the setting of the pressure relief valve.

- c) While observing the Pressure Gauge, slowly turn the Pressure Relief Valve counter-clockwise until you see liquid flow or the pressure drops. Keep track of the number of turns, as they will be used at a later step.

The Pressure LED should illuminate RED.

The Pressure gauge will show the pump start pressure. Adjust the Pressure Switch Range Adjustment Screw if the indicated start pressure is not correct for your application. To increase the trip pressure, turn the Pressure Switch Range Adjustment Screw clockwise. To decrease the trip pressure, turn the Pressure Switch Range Adjustment Screw counter clockwise.

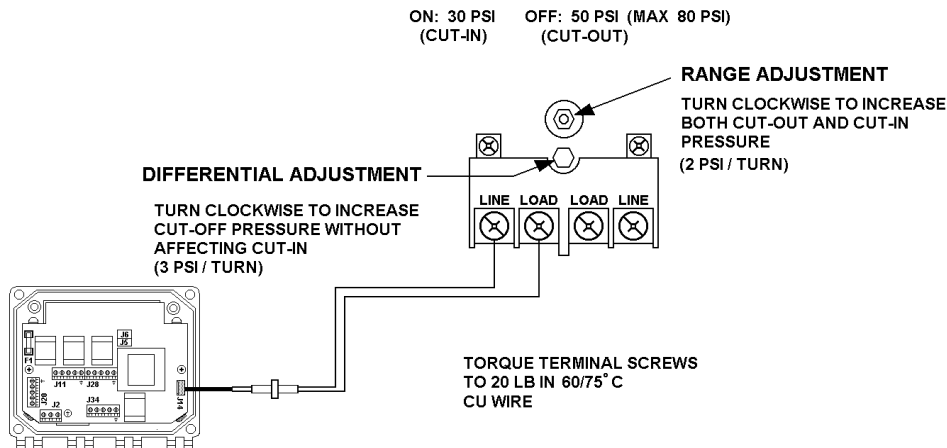

Figure 22 – High Pressure switch

10. Turn the Pressure Relief Valve clockwise to restore it to its previous setting.
11. Slowly open the Main Shutoff Valve.
 - a) Observe the pressure at which the Pressure LED shuts off.
 - b) Adjust the Pressure Switch Range Adjustment screw (refer to *Figure 22*) if the indicated pressure is not correct for your application.
 - c) Adjust the Pressure Relief valve setting clockwise until you see there is no liquid flow.
12. Repeat steps 7 – 11 until you have set the range.
13. Check that there is no flow. Adjust the Pressure Relief Valve if necessary.



You may need to repeat this step several times before the system is “fine tuned” to the desired operating pressure.

There is an optional low pressure switch (Pulsafeeder Part #: 12-140-01) available for the Digital Glycol Feeder system. If you have this switch, follow steps 1 – 13 to perform the start up procedure. *Figure 23* below shows the switch component layout.

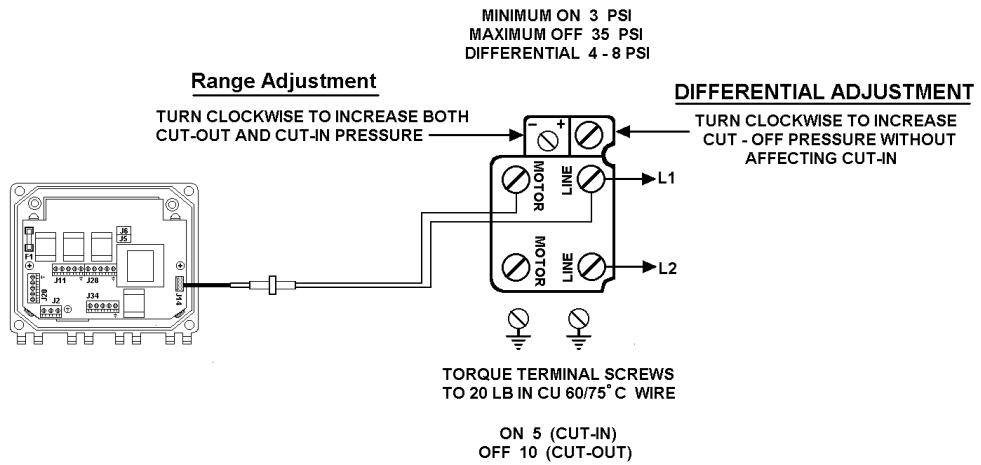

Figure 23 – Optional Low Pressure Switch

4. Operation

The DGF feeds glycol by monitoring the re-circulating glycol system pressure. When the pressure drops below the set pressure point, the pump operates until the set pressure point is reached.

The DGF will continue to feed glycol until the glycol level falls below the Tank Level Monitor switch. When this occurs, the pump will stop, and if your system has the optional audible alarm, the alarm will sound.

Following is an explanation of each mode, and how the system is effected when that specific mode is selected.

4.1 Operating Modes

4.1.1 Normal

During Normal operation, the Power LED (Green) is illuminated. The pump and the alarm keypad LED's will be in the "OFF"(Clear) state.

4.1.2 Feeding Glycol

If the system pressure drops causing the pressure switch to close, the Pressure 1 or Pressure 2 LED is illuminated (Red), the associated Pump LED is illuminated (Green) and the associated pump relay is activated.

4.1.3 Alarm

When the glycol level in the tank falls below the level sensor, the DGF enters an alarm state. While the system is in the "Alarm" state, it will not feed glycol (the pumps are locked out).

The pump(s) can be "Forced On" regardless of the alarm condition by pressing and holding the associated pump button until the Keypad LED is illuminated amber. When the pump is "Forced On", it will remain on while the key is being pressed. When the key is released, the system is returned to a condition determined by the monitors within the system.

The pump(s) can be "Forced Off" regardless of the alarm condition by pressing the associated pump button once, making the Keypad LED illuminate red. Once the pump(s) are forced off, the operator must press each pump button to achieve the desired equipment state.



NOTE

The system cannot be taken from a "Forced Off" state to a "Forced On" state. The pump must be in an "Auto On" or "Auto Off" state for the pump to be "Forced On." This is done as a safety measure in the system.

5. Specifications

5.1 Environment

Operating Temperature: 0°C to 50°C (32°F to 122°F)
Storage Temperature: -20°C to 60°C (-20°F to 140°F)
Enclosure Rating: NEMA 4X

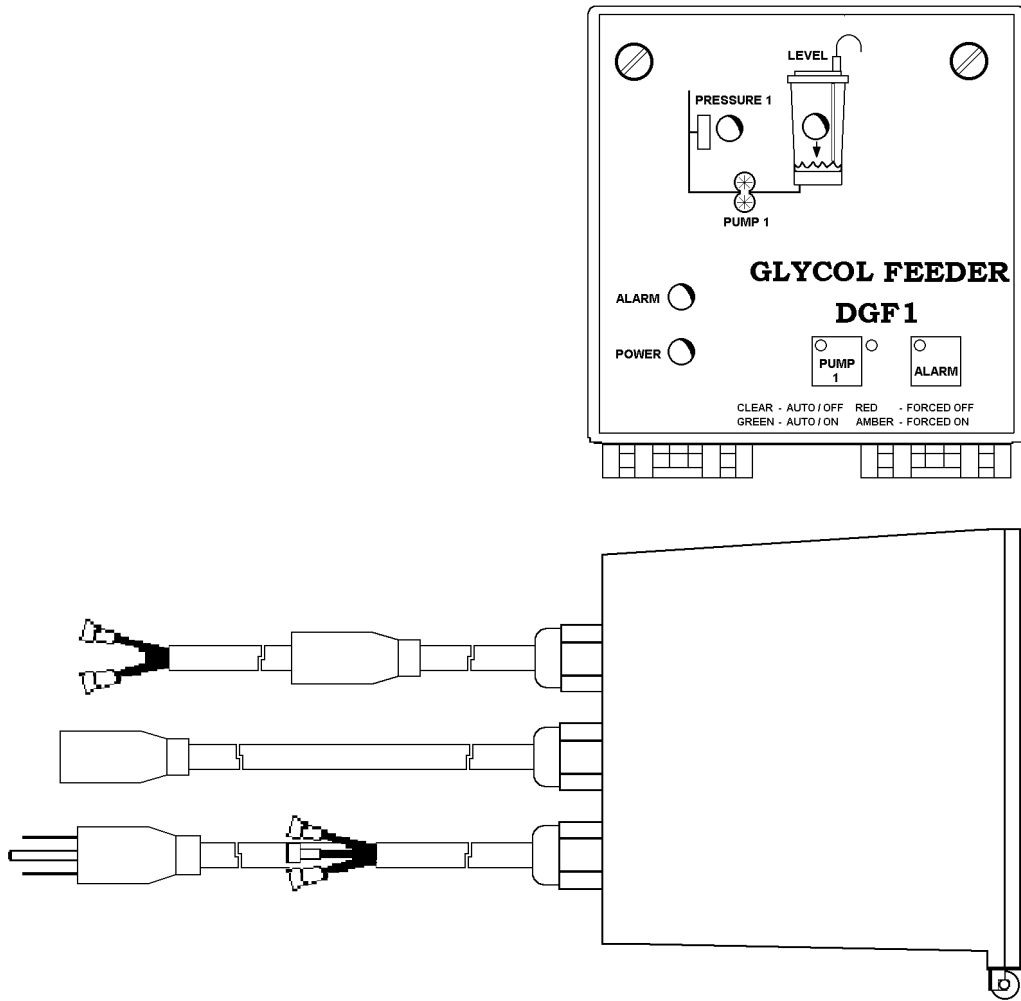

Figure 24 – General Layout: DGF1AEACXA

5.2 Power Requirements

1. 115/230 VAC 50/60 Hz. Factory configured. $\pm 10\%$
2. On 115V units, Alarm power is fused at the input with a 10-amp Time-Lag 5x20 glass fuse [located on the main circuit board] (Pulsafeeder Part # 05-052-17) in line with the main power cable.
On 230V units, Alarm power is fused at the input with a 5-amp Time-Lag 5x20 glass fuse [located on the main circuit board] (Pulsafeeder Part # 05-053-18) in line with the main power cable.
The Pumps are individually fused with a 12-amp Time-Lag $\frac{1}{4} \times 1 \frac{1}{4}$ (Pulsafeeder Part #05-051-79)
3. The power cable is 18 gauge, 3 wire, jacketed cable, 6 feet long.



DGF1 and DGF2 can be ordered without the power cable. This facilitates a hard wired power connection. (Refer to Section 2 for wiring specifications / connections.)

5.3 Inputs

1. Liquid level wand for the glycol tank.
2. One or two pressure switch inputs depending on the number of closed loops in the system.
Pressure rating options are as follows:
 - a) Standard Pressure switch (10-80 psi)
 - b) Low Pressure switch (3-35 psi)



The standard pressure switch is open between 50 psi and 80 psi and closes at or below 30 psi.

All the inputs above are connected to the controller through a 6 conductor cable with a Liquidtite on the enclosure.

A six pin locking header is on the circuit board side and 2 pin Molex connectors are on the sensor side.

5.4 Outputs

5.4.1 Pump

1. One (DGF1) or two (DGF2) AC pigtail plugs come out of the back of the enclosure for use with each accompanying pump. The pigtails will be wired Normally Open (NO) which will provide power to the pump when the Pressure Switch is activated (Pressure Low).



NOTE

The relays have a 16 amp at 120VAC and 8 amp at 230VAC contact rating.

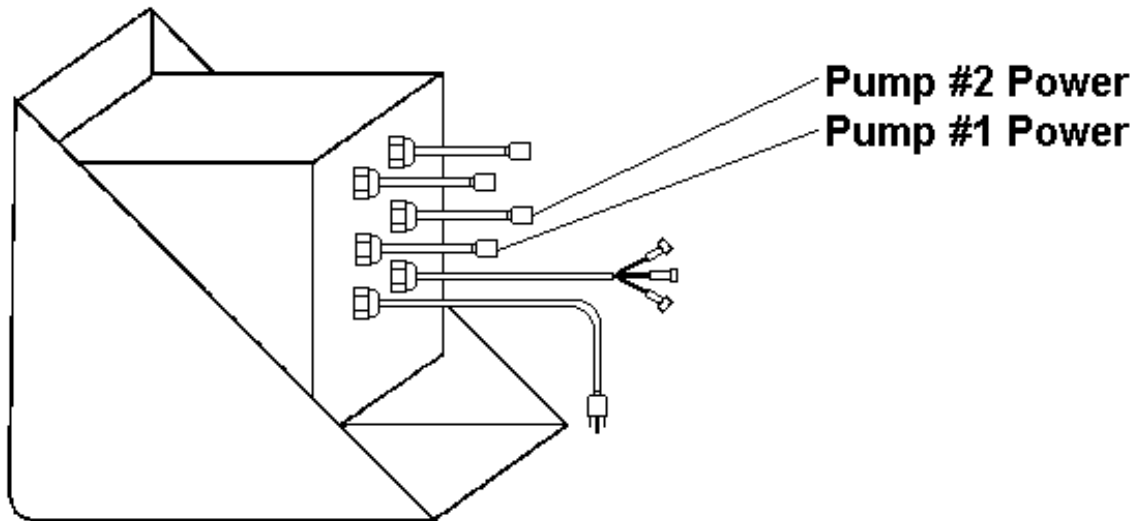

Figure 25 – Pump Power Pigtails



NOTE

Power Pigtails are not provided on a conduit unit.

5.4.2 Alarm

1. The unit has a DPDT dry contact relay option capable of supporting 120V at 2 amps. (No power is supplied to this relay.) The user may select either normally closed (NC) or Normally Open (NO) for each of the two alarm relay outputs.* The connector is a phoenix type block accessible from inside the box. The phoenix block will accept wire down to 14 gauge.
* Optionally, the Alarm Relay can supply AC power through a pigtail.

5.5 Audible Indicators

There is an optional 105db audible siren that is mounted on the side of the NEMA enclosure.

6. Trouble Shooting

Symptom	Action
No power light.	Verify power from the source.
	Check fuse. If necessary, for a 115VAC system, replace the 10-amp Time-Lag 5x20 Glass Fuse. (Pulsafeeder Part #: 05-052-17) or If necessary, for a 230VAC system, replace the 5-amp Time-Lag 5x20 Glass Fuse. (Pulsafeeder Part #: 05-053-18)
No power to pump.	Verify wiring.
	Low level alarm is on. Refill tank.
Solution in tank is OK but the alarm is still on.	Float is stuck in wand. Pull wand out and rinse with water.
	Wand float is installed backwards. Remove and reverse wand float direction.
Pump won't feed.	Pressure switch not activating. Check pressure switch settings.
	Strainer screen is clogged. Clean strainer.
Pump continuously runs.	Pressure relief valve is closed. Re-adjust pressure relief valve.
	Pressure switch stuck open. Re-adjust pressure switch.
	Refer to Pump won't feed.

7. Maintenance



REMOVE POWER FROM THE CONTROLLER BEFORE ANY ATTEMPT AT CLEANING IS MADE.

7.1 Cleaning

If your Glycol Feeder Controller requires cleaning, a mild soap or detergent can be used on the face and enclosure. Use only a mild soap or detergent to ensure that the overlay is not damaged in any way.

8. Pump Information

8.1 Drive

The pump is driven directly from the electric motor shaft by means of a flexible coupling. An aluminum adapter connects the pump to the motor.



The adapter is a type “C-Face”.

8.2 Suction Lift

A rotary gear pump is capable of lifting water on the suction side as high as 20 feet. Though gear pumps are self-priming, a foot valve is recommended.

A wet prime is required for the first dry start. Liquid retained in the system and gear chambers serves to wet the pump during subsequent starts.

8.3 Rotation

The pump motor supplied by the factory has a clockwise shaft rotation as viewed from the pump head. Reversing the motor rotation will reverse the “In” and “Out” ports.

To reverse single-phase motors, find the illustrations on the inside of the junction box cover or on the motor name plate.

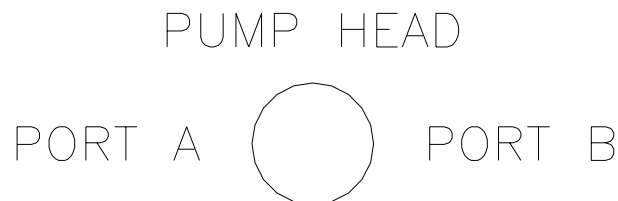

WIRING MOTOR CLOCKWISE:

PORT A = SUCTION PORT

PORT B = DISCHARGE PORT

WIRING MOTOR COUNTERCLOCKWISE:

PORT A = SUCTION PORT

PORT B = DISCHARGE PORT

**WARNING: DO NOT RUN PUMP DRY (MAX 20 SEC's)
PUMP HEAD DAMAGE WILL OCCUR**

**MODEL
N991
SERIES**

**BRONZE CLOSE COUPLED
ROTARY GEAR PUMPS**



OBERDORFER PUMPS

A Subsidiary of Thomas Industries Inc

EXPLODED VIEW AND PARTS LIST

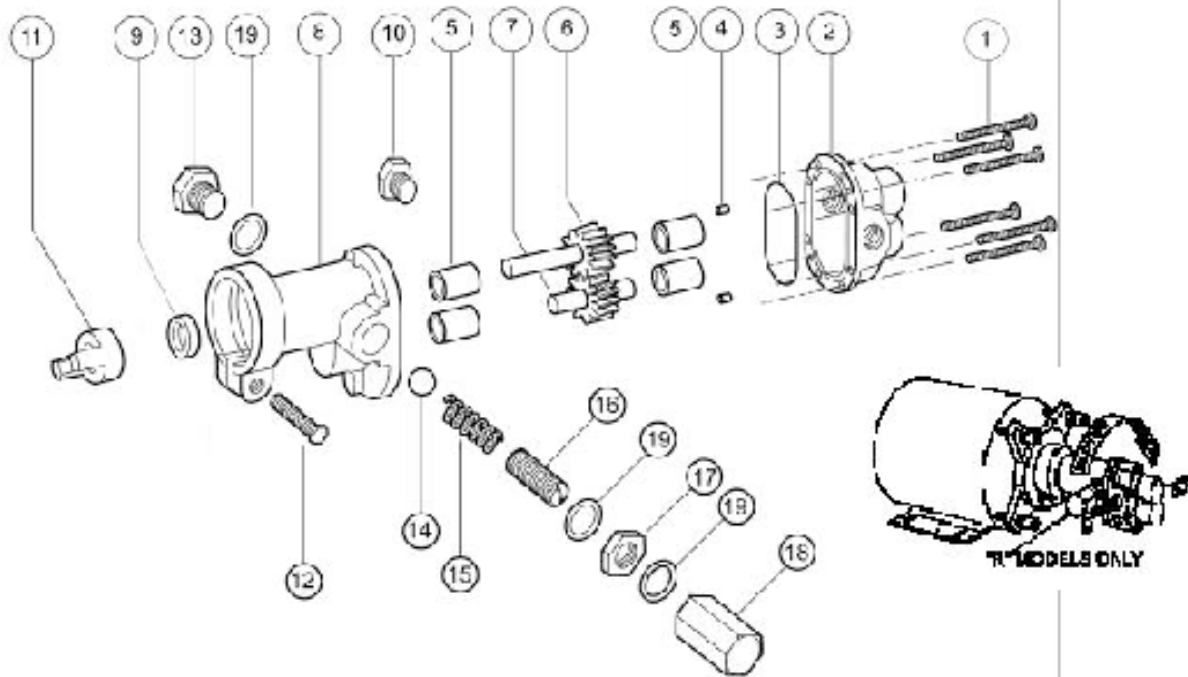

Pump No.	1	2	3	4	5	6	7	8	9	10	11	12	13	14	15	16	17	18	19
	Screw	Body	O-Ring	Dowel Pin	Bearing	Drive Gear Assy.	Idle Gear Assy.	Cover	Lip Seal	Cap Plug	Coupling	Screw	Plug Nut	Ball	Spring	Adj. Screw	Locknut	Bypass Nut	Riber Washer
	6 Req'd	1 Req'd	1 Req'd	2 Req'd	1 Req'd	1 Req'd	1 Req'd	1 Req'd	1 Req'd	1 Req'd	1 Req'd	1 Req'd	1 Req'd	1 Req'd	1 Req'd	1 Req'd	1 Req'd	1 Req'd	3 Req'd
N991	9D13	9CDDNBSM	979F-033	8885	5D24	3Z98D	3Z979	9CDDN2M	9D17	9C96	9D14	9B95	—	—	—	—	—	—	—
N991R	9D13	9CDDNBSM	979F-033	8885	5D24	3Z98D	3Z979	9CDDN2B	9D17	9C96	9D14	9B95	9C38	9B13	9B10	9Z37	9Z10	9Z39	9533

¹ Seal # 5007 is Standard Buna N, # 7580 is Viton(R)*-Te-flon(R)*

² Repair Kit contains items 3, 5, 6, 7 & 9. Repair Kit for N991(R) is # 10640.

VARIATIONS

Pump No.	g ^{1,2}	
	Lip Seal	Repair Kit ²
N991S5	7580	11318
N991RS5	7580	11318

*Viton(R) or equivalent FKM will be used. Viton(R) is a registered trademark of DuPont

PTFE will be used.

DIMENSIONS

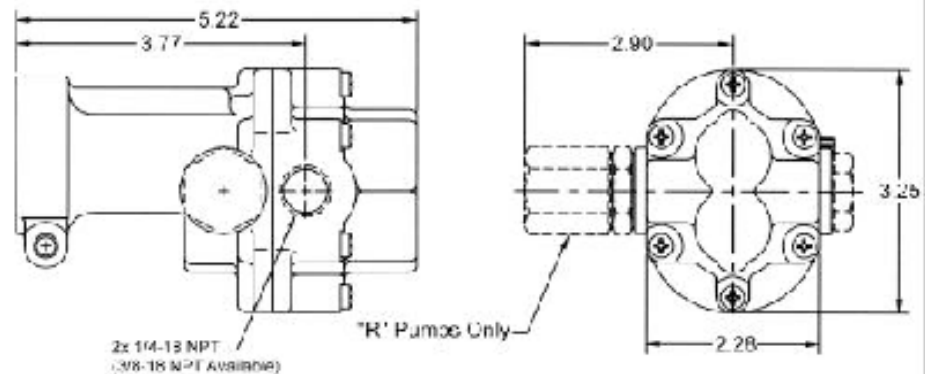

**MODEL
N993
SERIES**

**BRONZE CLOSE COUPLED
ROTARY GEAR PUMPS**



OBERDORFER PUMPS

A Subsidiary of Thomas Industries Inc.

EXPLODED VIEW AND PARTS LIST

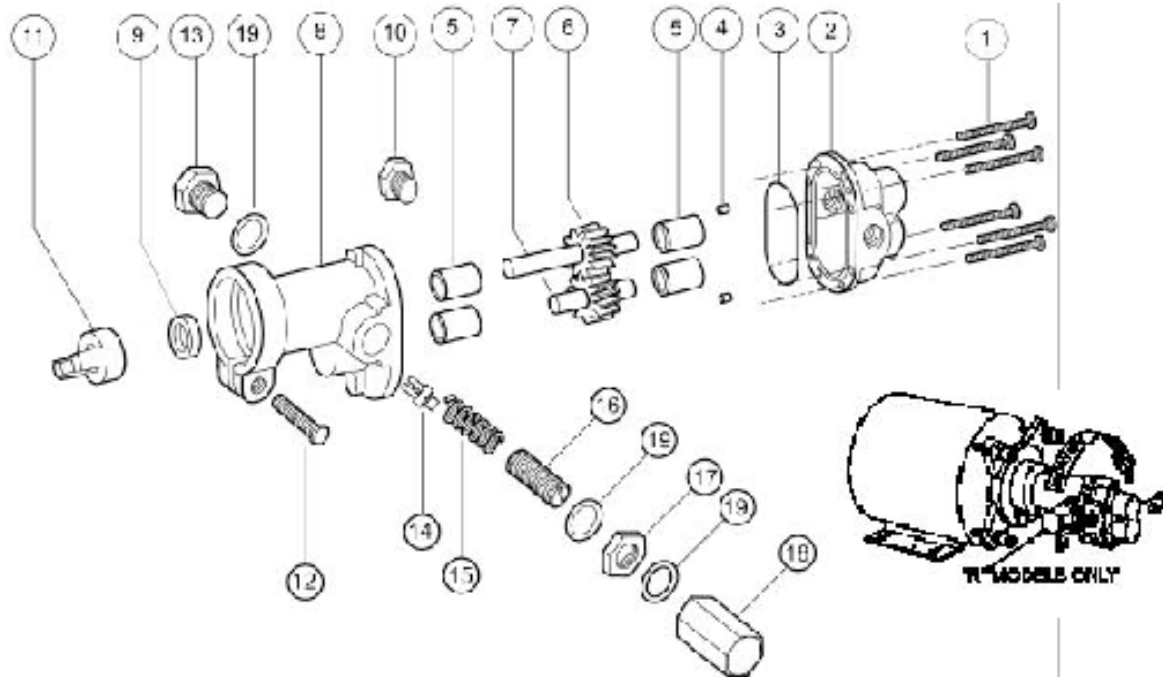

Pump No.	1	2	3 ¹	4	5 ¹	6 ¹	7 ¹	8	9 ¹	10	11	12	13	14	15	16	17	18	19
	Screw	Body	O-ring	Dowel Pin	Bearing	Drive Gear Assy.	Idle Gear Assy.	Cover	Lip Seal	Cap Plug	Coupling Half	Screw	Plug Nut	Poppet	Spring	Adj. Screw	Locknut	Bypass Nut	Fiber Washer
	6 Req'd	1 Req'd	1 Req'd	2 Req'd	1 Req'd	1 Req'd	1 Req'd	1 Req'd	1 Req'd	1 Req'd	1 Req'd	1 Req'd	1 Req'd	1 Req'd	1 Req'd	1 Req'd	1 Req'd	1 Req'd	3 Req'd
N993	9637	9307 ND5M	9797-036	8885	5024	32950	32937	9335M N2M	9007	9946	9804	9595	--	--	--	--	--	--	--
N993R	9637	9307 ND5M	9797-036	8885	5024	32950	32937	9335M N3R	9007	9946	9804	9595	1838	6535	6301	5237	5240	5239	6533

¹ Seal #5007 is Standard Buna N, #7580 is Viton(R)-Te-flon(R)

² Repair Kits contain items 3, 5, 6, 7 & 9. Repair Kit for N993(R) is #12070.

VARIATIONS

Pump No.	g ^{1/2}	
	Lip Seal	Repair Kit ²
N993S5	7580	12101
N993RS5	7580	12101

*Viton(R) or equivalent FKM will be used. Viton(R) is a registered trademark of

used. PTFE will be

DIMENSIONS

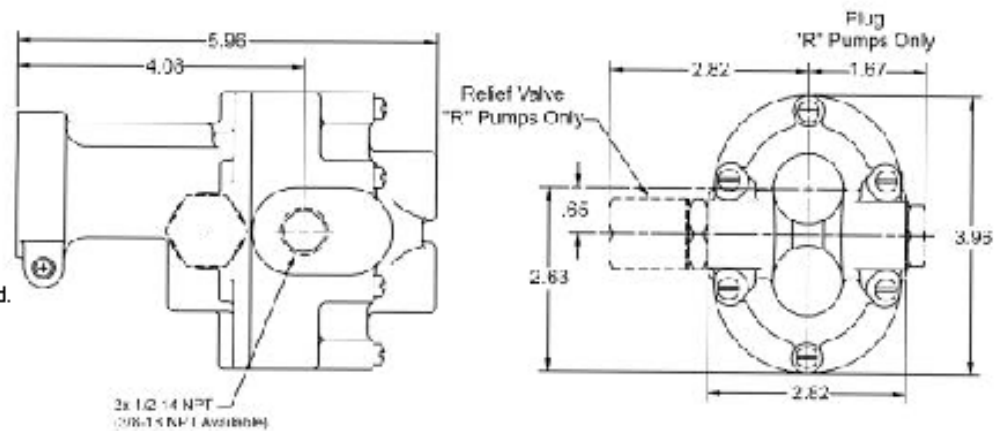

3x 1/2-14 NPT
(2x 1/2-14 NPT Available)

Notes:

Appendix A – Reference Charts

Reference Chart % Propylene Glycol					
Weight % Propylene Glycol	Volume % Propylene Glycol	Freeze Point °f	Refractive Index N _D 77°f	Degree Brix	Boiling Point °f @ 760MM Hg
20	19.4	19.9	1.3565	15.4	213°f
21	20.4	19.0	1.3575	16.0	
22	21.4	18.0	1.3586	16.7	
23	22.4	17.0	1.3598	17.4	
24	23.4	16.0	1.3611	18.4	
25	24.4	15.0	1.3621	18.8	214°f
26	25.3	14.0	1.3632	19.6	
27	26.4	13.0	1.3643	20.2	
28	27.4	12.0	1.3654	20.8	
29	28.4	11.0	1.3664	21.4	
30	29.4	9.1	1.3674	22.0	216°f
31	30.4	8.0	1.3685	22.7	
32	31.4	7.0	1.3700	23.6	
33	32.4	6.0	1.3714	24.4	
34	33.5	4.0	1.3729	25.3	
35	34.4	3.0	1.3742	25.1	217°f
36	35.5	1.0	1.3755	26.9	
37	36.5	0	1.3765	27.5	
38	37.8	-2.0	1.3775	28.0	
39	38.5	-4.0	1.3785	28.5	
40	39.6	-5.0	1.3796	29.1	219°f
41	40.6	-7.0	1.3806	29.6	
42	41.6	-9.0	1.3816	30.2	
43	42.6	-11.0	1.3826	30.7	
44	43.7	-13.00	1.3837	31.1	
45	44.7	-15.0	1.3847	31.8	220°f
46	45.7	-17.0	1.3857	32.4	
47	46.8	-19.0	1.3868	33.0	
48	47.8	-22.0	1.3878	33.5	
49	48.9	-25.0	1.3889	34.1	
50	49.9	-29.0	1.3899	34.7	222°f
51	50.9	-31.0	1.3911	35.5	
52	51.9	-33.0	1.3922	35.9	
53	53.0	-37.0	1.3936	36.6	
54	54.0	-40.0	1.3947	37.2	
55	55.0	-43.6	1.3961	38.0	222°f
56	56.0	-46.0	1.3968	38.4	
57	57.0	-50.0	1.3891	39.1	
58	58.0	-53.0	1.39911	39.6	
59	59.0	-57.0	1.4002	40.3	
60	60.0	-60.0	1.4012	40.7	225°f

Reference Chart % Ethylene Glycol					
Weight % Ethylene Glycol	Volume % Ethylene Glycol	Freeze Point °f	Refractive Index N _D 77°f	Degree Brix	Boiling Point °f @ 760MM Hg
20	18.1	17.0	1.3525	13.0	216°f
21	19.2	16.5	1.3536	13.7	
22	20.1	16.0	1.3546	14.3	
23	21.0	14.0	1.3555	14.8	
24	22.0	13.0	1.3565	15.4	
25	22.9	12.0	1.3575	16.0	218°f
26	23.9	11.0	1.3585	16.6	
27	24.8	10.0	1.3590	17.0	
28	25.8	9.0	1.3606	17.7	
29	26.7	8.0	1.3615	18.5	
30	27.7	7.0	1.3625	19.0	220°f
31	28.7	5.0	1.3636	22.8	
32	29.6	4.0	1.3645	23.4	
33	30.6	2.0	1.3645	20.9	
34	31.6	1.0	1.3666	21.5	
35	32.6	0.0	1.3677	22.2	221°f
36	33.5	-1.0	1.3686	22.8	
37	34.5	-3.0	1.3696	23.4	
38	35.5	-4.0	1.3707	24.0	
39	36.5	-5.0	1.3718	24.6	
40	37.5	-8.0	1.3728	28.2	224°f
41	38.5	-9.0	1.3729	29.1	
42	39.5	-11.0	1.3750	26.5	
43	40.5	-13.0	1.3760	27.2	
44	41.5	-15.0	1.3770	27.7	
45	42.5	-17.0	1.3780	28.2	225°f
46	44.0	-20.0	1.3796	29.1	
47	45.0	-22.0	1.3806	29.6	
48	46.0	-24.0	1.3818	30.2	
49	47.1	-26.0	1.3828	30.8	
50	48.0	-28.0	1.3837	31.3	227°f
51	49.1	-31.0	1.3848	31.9	
52	50.1	-35.0	1.3858	32.5	
53	51.2	-36.0	1.3869	33.1	
54	52.2	-38.0	1.3880	33.6	
55	53.2	-43.0	1.3889	34.1	227°f
56	54.3	-45.0	1.3968	38.4	
57	55.3	-50.0	1.3909	35.2	
58	56.3	-52.0	1.3919	35.7	
59	57.4	-54.0	1.3930	36.4	
60	68.4	-58.4	1.3939	36.8	230°f



STANDARD PRODUCTS OPERATION

Pulsafeeder, Inc.
27101 Airport Rd.
Punta Gorda, FL 33982
USA
www.pulsa.com

EUROPEAN UNION

Warren Rupp Europe Limited
PO Box 91
Washington
NE37 1YH England
Telephone: 0191 419 0999
Fax: 0191 418 3500