



XP Peristaltic Pump Installation, Operation and Maintenance Manual

7 Day Electronic Timer



Tested and Certified by WQA
against NSF/ANSI 61-Section 8.
and CSA B483.1



TABLE OF CONTENTS

1. Introduction.....	3
2. Safety Instructions.....	3
3. Technical Specifications.....	4
4. Installation.....	5
5. Operation.....	6
5.1. 7 Day Electronic Timer.....	6
5.2. General.....	11
6. Maintenance.....	11
6.1. Tubing Assembly Removal.....	12
6.2. Tubing Assembly Installation and Lubrication.....	13
6.3. Pools and Spas.....	15
7. Policies and Procedures.....	16
7.1. Manufacturers Product Warranty.....	16
7.2. Returns.....	16
7.3. Credits.....	17
I. Pump Assembly and Wiring Diagram.....	18
Maintenance Record.....	19

1. Introduction

Thank you for your purchase of the Chem-Tech Series XP peristaltic pump from Pulsafeeder. We appreciate your decision to purchase a Pulsafeeder product. Please take this time to become familiar with your pump and the number of accessories that shipped with your product.

The shipping box contains the following items:

- 1) Peristaltic pump comprising of: a) pump head and tube assembly, b) Snap-on rear rain guard (this can be found in the sealed bag that shipped with the product).
- 2) Instruction Manual.
- 3) Factory Replacement tube
- 4) Suction and Discharge tubing set (15-feet of ¼-inch OD Polyethylene Tubing).
- 5) Injector Valve
- 6) Strainer w/ Ceramic Weight.

2. Safety Instructions

READ AND UNDERSTAND ALL INSTRUCTIONS PRIOR TO USE. Failure to follow or understand instructions can/may lead to serious injury or death.

- **WARNING:** Secure chemicals & metering pumps, making them inaccessible to children & pets.
- **WARNING: DO NOT PUMP FLAMMABLE LIQUIDS.**
- **WARNING:** To reduce the risk of electrical shock-before maintenance, repair, or moving always disconnect the power to the pump by unplugging from wall outlet.
- **WARNING:** Do not tamper with, cut the plug or ground lug off the electrical cord. Consult a licensed electrician for proper installation.
- **WARNING:** Always wear protective clothing, including gloves and safety eye protection, when working on or near chemical metering pumps, consult chemical manufacture for protective equipment recommendations.
- **WARNING:** Always make sure the voltage on the pump data plate matches the installation voltage before plugging the pump into a wall outlet or hooking up to an electrical supply. If you are unsure have a licensed electrician inspect and install your pump.
- **WARNING:** Always depressurize system and drain the chemical prior to installation or maintenance.
- **WARNING:** Read and fully understand the section on tube replacement. Failure to do so may lead to serious injury.
- **WARNING: DO NOT MODIFY PUMP**, as this poses a potentially dangerous situation and voids the warranty.
- **WARNING:** If the injection point is lower than the chemical tank and pump, install an anti-siphon valve.

- **WARNING:** All pumps are factory tested with water. Remove tubing and thoroughly dry if the chemical being pumped will react with water (for example: sulfuric acid).
- **WARNING:** Only finger tighten plastic connections (Do not use a wrench).
- **WARNING:** Consult licensed plumber and electrician before installation to be sure to conform to local codes.
- **CAUTION:** Inspect tubing regularly for cracking or deterioration and replace as necessary. (Always wear protective clothing and safety eye protection when inspecting tubing.)
- **CAUTION:** KEEP FINGERS AWAY FROM ROTATING PARTS.
- **CAUTION:** If the pump is exposed to direct sunlight, use a U.V. resistant tubing.
- **CAUTION:** Follow directions and warnings provided with the chemical from the chemical manufacturer. The user is responsible for determining the chemical compatibility with the chemical feed pump.
- **CAUTION:** Consult with local health officials and qualified water conditioning specialists when treating potable water
- **CAUTION:** For accurate volume output, the pump must be calibrated under all operating conditions.

3. Technical Specifications

Refer to the data plate located on the back of the peristaltic pump. Note that the data plate will be located behind the back splash cover if installed. Please make note of the Electrical Rating, Feed Rate and Maximum Pressure of the pump. Use this information to complete the top three lines in Table 1 (below) by. For example, if the Electrical Rating indicated on the data plate of the pump is 230V/60 Hz fill in the first line of the table below. Keep this information handy for future reference and part replacement.

Figure 1 provides a quick reference for installation dimensional requirements.

Table 1: Technical Specifications

Electrical Rating	
Feed Rate (GPD)	
Feed Rate (LPH)	
Maximum Pressure (PSI)	
Maximum Pressure (Bar)	
Maximum Ambient Temperature	104°F (40°C)
Pump Safety Rating	ETL_CETL, ETL_{SAN}, NSF 50*
Enclosure Rating	NEMA 3R (IP31)
Pump Head	PVC
Pump Head Tubing	Norprene
Injection Fitting	PVC
Strainer	Polypropylene
Suction/Discharge Tubing	Polyethylene
Pump Housing	ABS or Polycarbonate/PBT/15%GF

*Except 50GPD (7.9 LPH) and 80GPD (12.6 LPH) Feed Rate pumps.

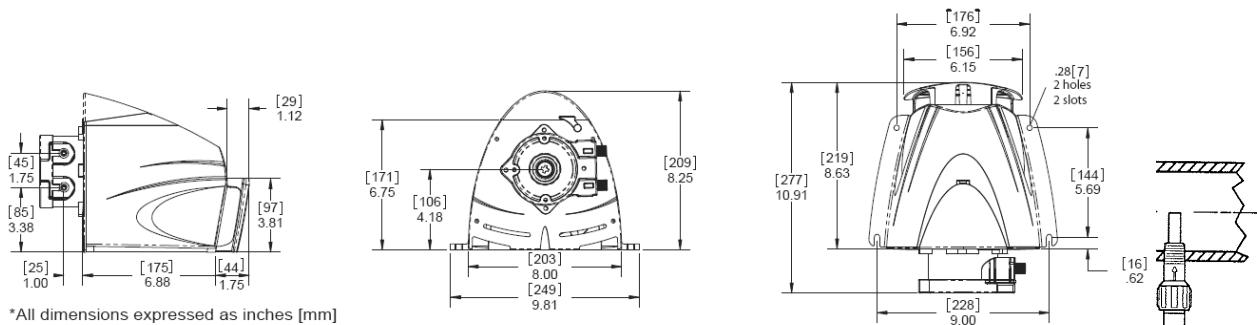

Figure 1: Pump Dimensions

4. Installation

NOTE: For pumps operating in swimming pool installations the pump is to be supplied by an isolating transformer or through a residual current device (RCD).

1) The pump can be installed either vertically or horizontally (See Figure 2). Make sure to secure the pump on a flat level surface that will support 50-lbs (22kg) and secure with four .25-in (6mm) screws in the holes provided. The guard snaps into the back of the pump via three tangs -- see Figure 1. The pump should be mounted with no less than 1.75-in (44mm) of clearance around the venting on both the front and the rear of the pump. Locate the pump so there is direct access to the power cord plug.

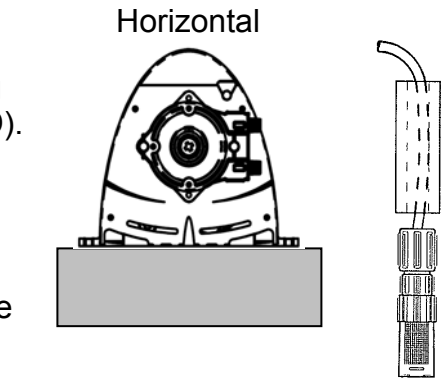

Figure 2: Injector Placement

The pump is rated for indoor use only. For applications that are subject to splashing, make sure the pump is mounted horizontally level with splash guard in place. Vertical mountings require the purchase of optional hood (J63004). Select a location that does not subject the timers LCD to direct sunlight.

2) Verify the electrical requirements for the pump as listed on the name plate and connect to an appropriate electrical source in compliance with local codes for the specific application.

3) Relieve the system pressure and drain the piping run where the injection fitting is to be installed. See Figure 2 for reference. **The injection fitting must not be installed in a dead end pipe or a deeply recessed tee. It should be installed so as to place the tip at the center of the fluid stream as indicated in Figure 2.** The injection fitting is supplied with .25-in NPT threads. If necessary drill a .44-in (11mm) diameter hole and using care not to tap too deeply, tap for .25-in NPT.

4) Apply Pipe tape to the injection fitting threads and install into piping system. **Do not remove the plastic sleeve on the tip of the fitting; it is a functional part** – see Figure 4.

CAUTION: Inspect the piping system and eliminate piping cross-connections to prevent feeding chemical to areas not needing treatment.

To install tubing remove the compression fitting's coupling nut and slide onto tubing. Place tubing onto fitting and hand tighten the coupling nut. **NOTE:** Immerse tubing in hot water to soften prior to pushing on to fitting. **Hand-tighten only, do not use wrenches.**

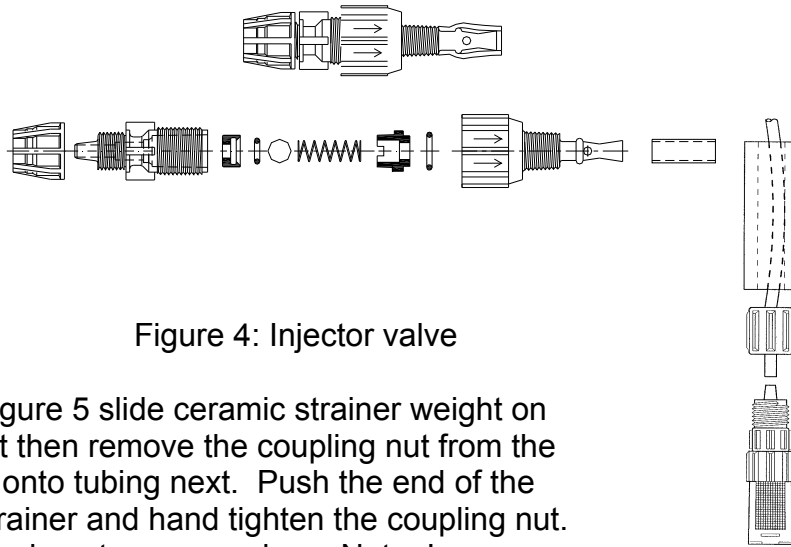

Figure 4: Injector valve

5) Referring to Figure 5 slide ceramic strainer weight on suction tubing first then remove the coupling nut from the strainer and slide onto tubing next. Push the end of the tubing onto the strainer and hand tighten the coupling nut. Hand-tighten only, do not use wrenches. Note: Immerse tubing in hot water to soften prior to pushing on fitting.

Figure 5: Ceramic-Weighted Strainer

6) Install the strainer so it is off the bottom of the chemical container (1 to 2-inches (25-50mm)) and measure suction tubing length required. Cut tubing ends square and install on suction fitting of the pump. Hand-tighten only, do not use wrenches.

5. Operation

WARNING: Always make sure the voltage on the pump data plate matches the installation voltage before plugging the pump into a wall outlet or hooking up to an electrical supply. If you are unsure, have a licensed electrician inspect and install your pump.

5.1. 7 Day Electronic Timer

CAUTION: Before plugging your pump into a wall outlet take a moment and locate the control panel of your pump. The control panel is located on top of the pump. The pump is equipped with a 3-position mode selector switch in the upper left side of the control panel. Verify the switch is in the off-position before plugging your pump into a wall receptacle – see Figure 6.

SYMBOL CROSS REFERENCE	
On	= I
Off	= 0
M.T.W.T.F.S.S	= 1,2,3,4,5,6,7
Day	= 1...7
h	= h+
m	= m+
Skip	= ><
Reset	= R

NOTE: SOME TIMERS
HAVE ALTERNATE
SYMBOLS, BUT
OPERATION IS
THE SAME.

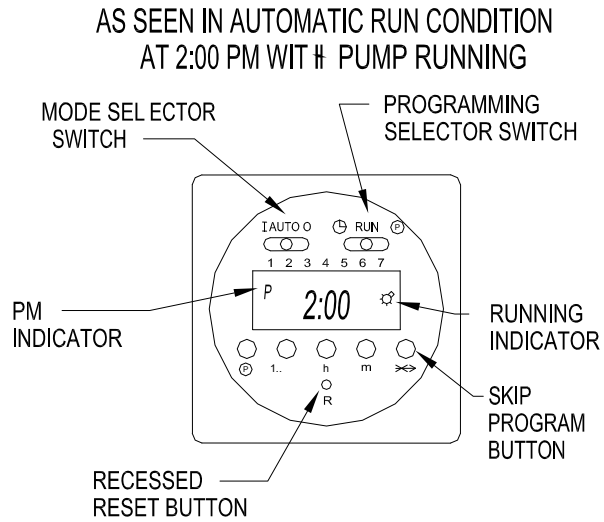

Figure 6

As previously mentioned the mode selector switch has three positions. The off-position is the right side position of the switch. The switch also provides a manually-on function in the far left side position. This function is very useful when priming and/or replacing worn tubing in the pump. The middle position sets the pump in the automatic (Timer) mode.

PUMP TIMER PROGRAMMING INSTRUCTIONS

1. Read all instructions first.

2. When programming or re-programming, use the program work sheet to set up the desired program before entering the steps into the timer. Seeing the program on paper may avoid errors and will make it easier to put the correct steps into the timer.
3. When re-programming, it is always best to use the 'R' reset button and re-program all cycles.
4. Avoid program sequences which overlap another program. Programs which start while another program is in the 'ON' sequence will not activate.
5. An 'EEE' on the screen indicates an error in program sequence. To correct, push the 'R' reset button; reset time of day and day of week; then re-program.
6. **CAUTION** Do not attempt to re-program while the timer is in the 'ON' sequence unless the 'R' recessed reset button is pressed first and all sequences are reprogrammed.
7. **CAUTION** Do not press the '⊕' button while in the 'time of day' (⊖) set mode. This may cause an error in the time keeping program which will cause hours: minutes to count in seconds. If this condition occurs, slide the programming selector switch to the '⊖' position, press the '⊕' button and the 'h' button at the sametime, then use the 'h' button to correct the time. When the time of day is corrected, slide the programming selector switch back to the 'RUN' position.
8. **CAUTION** Do not reset the time of day during an active cycle. Wait to reset during an 'OFF' cycle or use 'R' reset button and follow the complete instruction from the beginning.
9. All programming errors may be corrected by moving the right side button to the 'RUN' position and depressing the 'R' reset button. This will clear all memory, both 'time of day' and all programs. All desired programs and 'time of day' must be re-entered. Begin again at step #1.

Setting Time of Day:

1. With the programming selector switch in 'RUN' position, push recessed reset button, 'R' (0:00 will flash on the display).
2. Slide the programming selector switch to the left to the '⊖' 'time of day' position, (0:00 will appear on the display).
 - 2a. Use the '1..7' button to set 'day of week' using '1' as Monday. Put the day indicator '▲' under the day of week.
 - 2b. Use the 'h' button to set hour. 'P' will appear on the left side of the display to indicate P.M.
 - 2c. Use the 'm' button to set minutes.

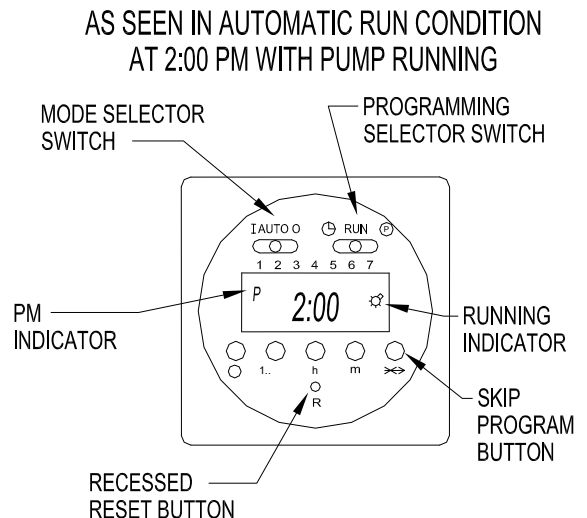

3. Slide the programming selector switch to center, 'RUN' position to check time setting. The colon';' will flash. Be certain that minutes do not change with each flash of the colon. If this condition occurs, an error has been made. Begin again at step #1.

NOTE: 1 Setting the time in the above sequence will clear all programs, reset the programs as required. (Skip step #1 to correct the time setting without clearing programs).

- NOTE 2.** Check the clock after completion of the time setting procedure. If the clock changes minutes with each flash of the colon, an error has occurred. To correct this condition, slide the programming selector switch to the '⊖' position. Push the '⊕' button and the 'h' button at the same time, then push the 'h' button to advance the hours to the correct time of day. Slide the programming selector switch back to the 'RUN' position.

Setting Programs: (refer to program worksheet (page 10) for guidance)

4. Slide programming selector switch right to program '⊕' position. (Screen will show "0:00 1 ☉") This indicates that you are setting the first event which is the 'ON' time for first cycle.
5. Use the '1...7' button to set the desired day(or days) of the week. Put the day indicator '▲' under the day or days) you want to run this program. Pressing the '1..7' button once will put the day indicator '▲' under Sunday (7), pressing again will move the day indicator '▲' to Monday (1). Continue pressing the button to advance day by day to Saturday (6). Press again to get multiple day programs.

Once	=	All weekdays (1 thru 5)	
Twice	=	Weekend only (6 and 7)	
3 Times	=	Every day except Sunday (1 thru 6)	L
4 Times	=	Every day (1 thru 7)	L
- 5a. Use the 'h' button to set **hour**, remember to set the time in A.M. or P.M. as required.
- 5b. Use the 'm' button to set **minutes**.
6. Push the program button; '⊕' to enter the data and set 'ON' time. The display will change to '0:00 2' ready for you to set 'OFF' time for first program.
- 7 Use **the '1...7'** button to set the day or days of the week for the 'OFF' cycle (refer to **5a** sequence). Day or days should match the day or days used in previous 'ON' cycle setting.
 - 7b. Set 'OFF' time for first program using the 'h' and 'm' buttons.
8. After setting time to desired 'OFF' time, press the '⊕' button. This completes Program 1. '0:00 3 ☉' will appear on the display ready to set the 'ON' time for next program.
9. If further programs are desired, continue setting program using Steps #5 thru #8.
 - 9a.If programming is complete, slide the program selector switch back to the 'RUN' position. All programs are now active.
10. To review program settings slide program selector switch to the '⊕' position. The display will show 'xx:xx 1 ☉' indicating the first 'ON' cycle, day and time. Press the '⊕' button again and the display will show 'xx:xx 2' the first 'OFF' cycle day and time. Continue pressing the '⊕' button to step thru the 'ON' and 'OFF' cycles of the rest of the program. After cycle 8 'xx:xx 8' is passed the display will return to the first cycle. The program selector switch may be returned to the 'RUN' position at anytime during review.

Running the Pump:

11. Position the mode selector switch ('I', 'AUTO', and 'O') to the position desired.

Position 'I'	=	Pump will run continuously, regardless of the program.
Position 'AUTO'	=	Pump will follow the program sequence.
Position 'O'	=	Pump will always remain off regardless of the program.

12. Skip cycle button: ⏏ ' may be used when you want to skip all program sequences programmed for the next day. Press the '⏏' button once, the '⏏' will appear in the lower right corner of the display. This will stop all program cycles from running the next calendar day (the day indicator '▲' will flash during the day which is being skipped).

PROGRAM WORKSHEET

(SYMBOLS ON TIMER MAY VARY)

CAUTION: SET TIME OF DAY PRIOR TO PROGRAMMING

PROGRAM	DAY(or DAYS)						
	1	2	3	4	5	6	7
1 ON 1	☼						
1 OFF 2							
2 ON 3	☼						
2 OFF 4							
3 ON 5	☼						
3 OFF 6							
4 ON 7	☼						
4 OFF 8							
5 ON 9	☼						
5 OFF 10							
6 ON 11	☼						
6 OFF 12							
7 ON 13	☼						
7 OFF 14							
8 ON 15	☼						
8 OFF 16							

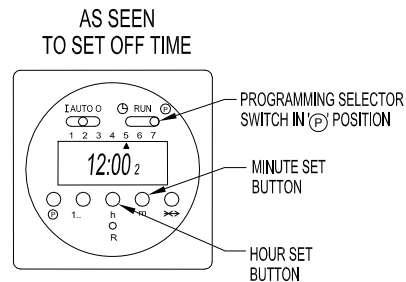
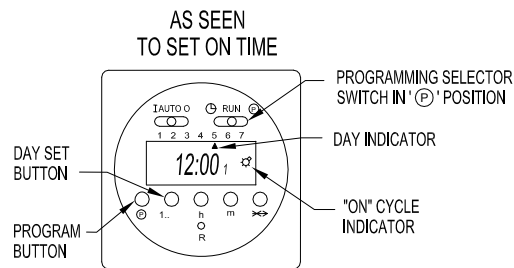
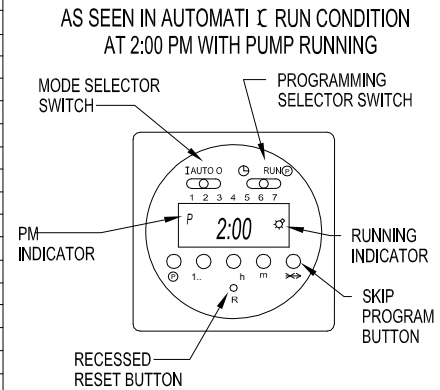

TO SET DAY OF WEEK, PRESS "1...7" BUTTON TO MOVE DAY INDICATOR '▲' TO DAY DESIRED(or DAYS). NOTE: ANY INDIVIDUAL DAY IS AVAILABLE. MULTIPLE DAY PROGRAMS ARE LIMITED TO THOSE SHOWN BELOW. SEE "SETTING PROGRAM", STEP 5A.

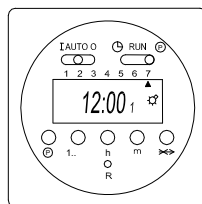

RUN SUNDAY

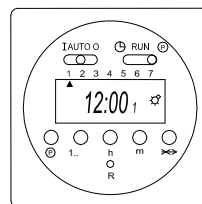

RUN MONDAY

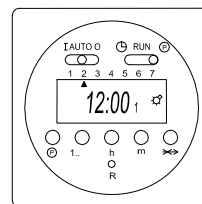

RUN TUESDAY

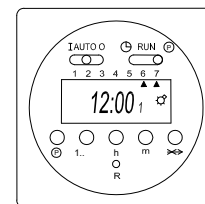

RUN SATURDAY & SUNDAY

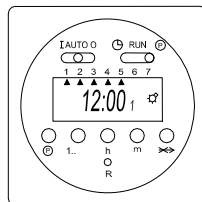

RUN ALL WEEK DAYS

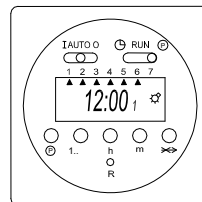

RUN EVERY DAY EXCEPT SUNDAY

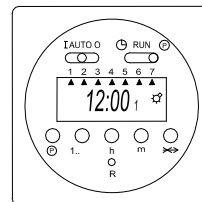

RUN EVERY DAY

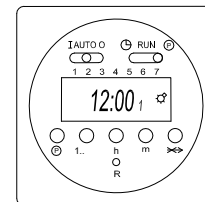

NO DAYS! WILL NOT RUN THIS PROGRAM

5.2. General

DANGER: DO NOT ATTEMPT TO FEED CHEMICALS WITHOUT FIRST CONSULTING YOUR CHEMICAL FEEDER DEALER OR CHEMICAL SUPPLIER. To avoid running out of chemical, follow a regular schedule of monitoring chemical supply.

CAUTION: Inspect peristaltic tubing frequently and replace when deterioration becomes apparent. Peristaltic tubing will eventually wear and break if neglected. This occurrence will cause chemical spillage and a potential for personal injury or damage to equipment. Always refer to chemical manufacturers recommendations with regards to safety and handling of hazardous or corrosive chemicals. Always wear protective clothing and safety glasses when working near chemical feed systems.

WARNING: Do not expose the pump or tubing to pressure exceeding the pressure rating on the pump nameplate.

- 1) Make sure the mode selector switch is in the off position...
- 2) Fill the chemical tank with the chemical to be fed.
- 3) Slide the model selector switch all the way to the left in the on position and make sure the programming selector switch is in the run position

6. Maintenance

NOTE : To get actual feed rates for specific settings, the output must be verified by measuring the volume output. Use the flow chart Figure #6, as a guide. To get the actual feed rate for specific settings, each pump must be calibrated for its flow. As with any peristaltic pump output varies tubing condition. It is recommended that feed rates be verified at every tubing change and after every 250-hour. More critical applications require more frequent verification.

NOTE: NO USER SERVICEABLE COMPONENTS ARE INSIDE THE ENCLOSURE. IF THE POWER SUPPLY CORD BECOMES DAMAGED, IT MUST BE REPLACED BY PULSAFEEDER, ITS REPRESENTATIVE, OR A SIMILARLY QUALIFIED TECHNICIAN IN ORDER TO AVOID A HAZARD.

6.1. Tubing Assembly Removal

Always wear protective clothing and safety glasses when working on the chemical pump and refer to the chemical manufacturers' safety precautions.

- 1) Remove the power to the pump and place the mode selector switch in the Off position.
- 2) Relieve the system pressure and the drain discharge and suction tubing.
- 3) Loosen coupling nuts and remove the tubing from suction and discharge ports. See figure 7a.

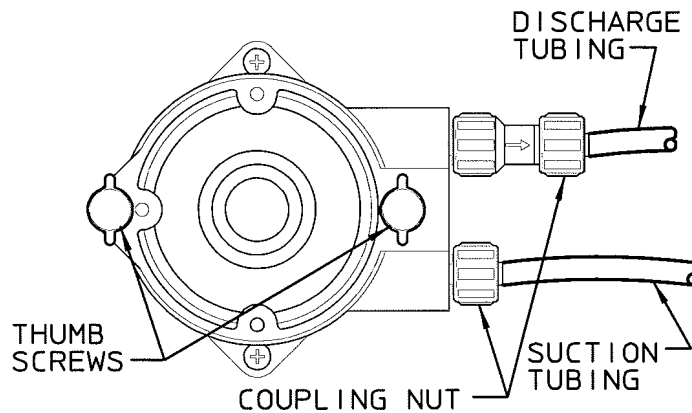

Figure 7a: Pump Head Assembly with Front Cover Attached

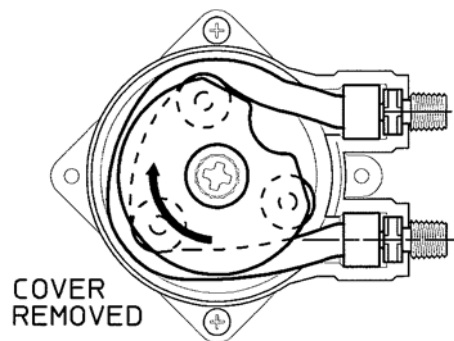

Figure 7b: Pump Head Assembly with Front Cover Removed

- 4) Remove the two thumb screws holding on the pump head cover and remove - See figure 7b above.

5) Remove pump head tube assembly by removing both connector fittings and pulling tubing straight out of the pump head. Tubing may retain a small amount of chemical. If the rotor assembly is removed, go to step #8.

6) Remove rotor assembly by pulling straight out of pump head. NOTE bearing lubrication every 500-hours; see section 6.2, "Tubing Assembly Installation and Lubrication".

7) Clean any tubing debris from the rotor assembly and pump head.

6.2. Tubing Assembly Installation and Lubrication

WARNING: When using the pump to load tubing the mode selector switch must be in the Off ("O") position to prevent accidental motor starting. Caution must be used to keep fingers away from rotating parts.

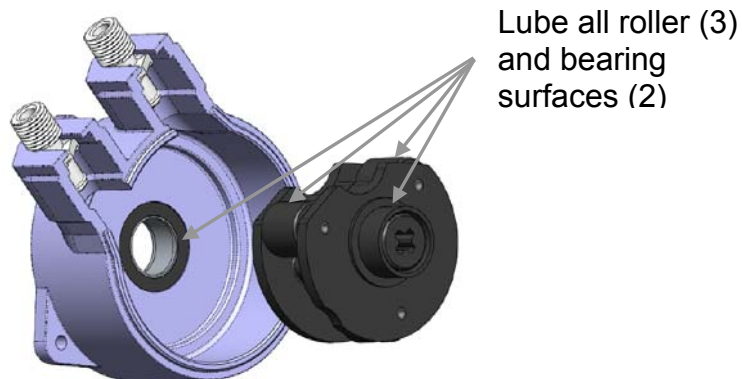

Figure 8: Pump Head w/ Rotor Assembly Removed

NOTE: Lubrication of rotor assembly should be performed at least once a year (residential service). Clean front and rear rotor bearings and surfaces with a clean shop cloth (item. No. 8, in assembly drawing on pg. 17). Lubricate with a PTFE thickened, medium viscosity, synthetic grease intended for plastic parts. Ref. Grease Kit (P/N J30257) – see Figure 8.

1) Reinstall the rotor assembly by aligning the cross in the rotor to the drive shaft cross and fully insert into pump head.

2) With the programming selector switch in the run position, slide the mode sector switch all the way to the left into the on position and align the rotor assembly as shown in Figure 9a.

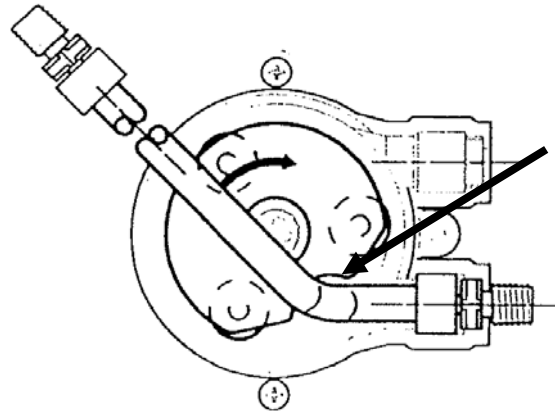
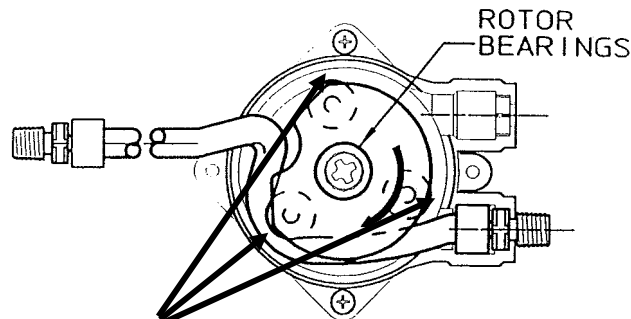

Figure 9a: Rotor Alignment at Start of Tube Installation

3) Insert one connector end of the tubing assembly into the bottom retaining slot in the pump head. Insert the tube through the guide slot in the rotor. Using caution, intermittently jog the mode selector switch to from the on and off positions and feed the tube around the pump head as the guide slot rotates. **Be very careful not to get any objects (fingers, ties, hair, etc.) close to the rotors and pump head as severe pinch points exist, see Figure 9b. Keep hands and fingers away from the rotor assembly while feeding the new tube.**



WARNING: Note severe pinch points between rollers and pump housing

Figure 9b: Feeding the New Tube

When the rotor is positioned as in Figure 9c, set the mode selector switch all the way to the right into the off position. Insert the other connector into its retaining slot.

- 4) Align the pump head cover bearing bore with the rotor shaft and press into place.
- 5) Loosely reinstall the two thumb screws.

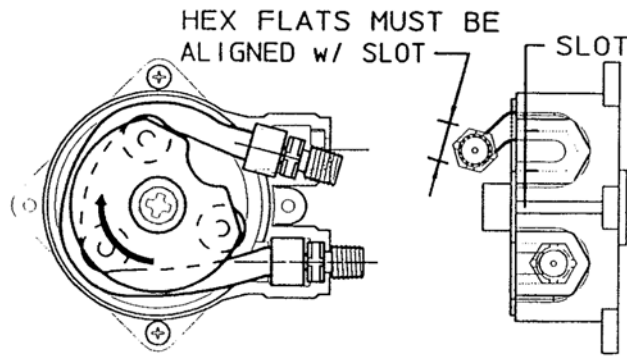

Figure 9c: Finishing the New Tube Installation

- 6) Using the mode selector switch, run the pump for several revolutions and then fully tighten the thumb screws hand tight.
- 7) Return the pump to service by following the procedures in the installation section.

6.3. Pools and Spas

Pumps carrying the “ETL Sanitation” (tested to NSF Standard-50) marks are listed for swimming pools, spas and hot tubs, and when proper materials are selected, are capable of handling but not limited to the following chemical solutions:

12.0% ALUMINUM SULPHATE,	5.0% SODIUM CARBONATE,
2.0% CALCIUM HYPOCHLORITE,	10.0% SODIUM HYDROXIDE,
12.5% SODIUM HYPOCHLORITE,	10.0% HYDROCHLORIC ACID.

To meet the requirements of the “ETL Sanitation Mark” qualification, 1) Replace the peristaltic tubing (as described above), 2) Grease the rotor bearing and 3) Oil the three rotor rollers at intervals of 500-hours operation time (actual running time).

7. Policies and Procedures

7.1. *Manufacturers Product Warranty*

PULSAFEEDER warrants equipment of its manufacture to be free of defects in material or workmanship. Liability under this policy extends for 24-months from the date of shipment. The manufacturer's liability is limited to repair or replacement of any failed equipment or part which is proven defective in material or workmanship upon manufacturers' examination. This warranty does not include removal or installation costs and in no event shall the manufacturers liabilities exceed the selling price of such equipment or part.

The manufacturer disclaims all liability for damage to its products through improper use, installation, maintenance or attempts to operate such products beyond their functional capacity, intentionally or otherwise, or any unauthorized repair. Replaceable elastomeric parts, including peristaltic tubing, are covered for 12 months. The manufacturer is not responsible for consequential or other damages, injuries or expense incurred through the use of its products.

The above warranty is in lieu of any other warranty, either expressed or implied. The manufacturer makes no warranty of fitness or merchantability. No agent of ours is authorized to provide any warranty other than the above.

For warranty and service matters within the European Union, contact the seller or:

Pulsafeeder, Inc
Units 12 and 13, Edison Road
Highfield Industrial Estates
Eastbourne,, East Sussex BN23 6PT

7.2. *Returns*

The Customer Service Department will issue a Return Authorization (RA) number for all returns.

The following information will be required:

1. Billing and a ship-to address.
2. Model and serial number.
3. Contact name and phone number.
4. Reason for return.
5. Purchase order (where applicable).
6. RA number on outside of the carton.
7. Type of chemical that was pumped.

All material must be returned freight prepaid. All merchandise must be properly packaged and free of any corrosive, toxic or otherwise hazardous chemical. All items returned must reference Return Authorization number.

7.3. Credits

No equipment will be accepted beyond six months after date of shipment from the factory. Only unused and undamaged equipment will be accepted for return to stock. All credits are based on acceptance of materials as new and unused by our inspection personnel. A restocking fee will apply. All equipment returned for credit must have a RA number and be returned freight prepaid.

Appendix

I. Pump Assembly and Wiring Diagram

XP 7 DAY TIMER

BILL OF MATERIALS

ITEM NO.	PART NUMBER	DESCRIPTION	QTY
1	J63000	HOUSING, BACK	1
2	J63003	ENCLOSURE, FRONT	1
3	J63004	ENCLOSURE, SPLASH HOOD	1
4	J63057	CONTROL PANEL, 7 DAY TIMER	1
5	J63016, J63017, J63018, J63019	MOTOR, 30/50RPM/120/230V/50-60HZ (SEE BOM FOR CORRECT MOTOR)	1
6	J63020	BAFFLE PLATE	1
7	J63022	O-RING	1
8	J63141	OVERLAY, CNTRL PNL 7 DAY TIMER XP	1
9	NC91XXXXXX-XXXXX	HEAD/ROLLER ASSEMBLY (SEE BOM FOR CORRECT HEAD ASSEMBLY)	1
10	NC1900000-000	THUMBSCREW W/KNOB	2
11	L9806300-188	SCR #10-32X.62 PAN HD PHIL	2
12	L9809601-000	#6 PAN HEAD SELF TAPPING SCREW 3/8" LNG-TYPE BT	1
13	06-135-00	RUBBER GROMMET	1
14	06-203-07	#6 X .38 LNG PHSMS TYPE A	2
15	L9890100-188	SCREWS(SST), #8 X 1/2 LNG TYPE-BT (TYPE-25)	4
16	J63139	SCRW SOC HD LK PTCH; 10-32X.75 TIMER DIG / AMPM/T 20/5060W/DIN	4
17	U0818740 NC960004-000	TIMER DIG / MIL/240V5-6HZ W/DIN (SEE BOM FOR CORRECT TIMER)	1
18	J63142	MTG BRKT, 7 DAY TIMER	1
19	06-205-01	SCREW, 6-32 X 5/8, FHP, 18-8	2

EC Declaration of Conformity

We, Pulsafeeder Inc., declare under sole responsibility that the Series XP metering pump, to which this declaration relates, is in sole conformity with relevant sections of the applicable EC standards and other normative documents listed on this document. If changes are made to the product which is covered by this declaration of conformity, the declaration of conformity is no longer valid.

- Application of Council Directive: 73/23/EEC and 93/68/EEC
- Standard to Which Conformity is Declared: IEC/EN 60335-2-41